

corai
Outils coupants

FORETS

FRAISES

TARAUDS

catalogue 2015

corai



PERÇAGE page 1

Forets carbure p. 1

Forets HSS p. 17

TARAUDAGE page 37

Jeux de tarauds à main p. 40

Tarauds machine gaz p. 47

Tarauds machine métriques p. 55

Accessoires pour tarauds p. 64

FRAISAGE page 67

Fraises carbure matériaux durs p. 67

Fraises carbure général p. 77

Fraises PM HSS p. 101

Fraises HSSCo p. 109

Fraises HSS cône morse p. 135

Autres produits de fraisage p. 139

ALÉSOIRS page 159

FRAISES À LAMER page 169

FRAISES LIMES ROTATIVES page 171

COFFRETS page 183

INDEX GÉNÉRAL PAR RÉFÉRENCE page 187

FORETS CARBURE

			LISTE DES MATIÈRES							
			30HRc	aciers jusqu'à 45HRc	aciers jusqu'à 60HRc	aciers INOX	fontes	ALU	Titane	plastiques
A231	Forets carbure DIN 6539 extra-courts		p.2	●		●	●	●	●	
A232	Forets carbure DIN 338 courts		p.3	●		●	●	●	●	
A202	Forets carbure DIN 6537 3XD revêtus TiAIN		p.4	●	●	●	●			
A203	Forets carbure DIN 6537 5XD revêtus TiAIN		p.6	●	●	●	●			
A204	Forets carbure DIN 6537 3XD revêtus TiAIN avec arrosage		p.8	●	●	●	●			
A205	Forets carbure DIN 6537 5XD revêtus TiAIN avec arrosage		p.10	●	●	●	●			
A206	Forets carbure DIN 6537 8XD revêtus TiAIN avec arrosage		p.12	●	●	●	●			
A233 A234	Forets carbure NC 90° Forets carbure NC 120°		p.13	●	●	●	●	●	●	

● utilisation conseillée pour la matière concernée

DONNÉES TECHNIQUES

Conditions de coupe recommandées

pages 14 et 15



réf. A231

conditions de coupe recommandées p. 14

Ø perçage	Dimensions	Réf.	Prix unitaire TARIF H.T.	Ø perçage	Dimensions	Réf.	Prix unitaire TARIF H.T.
1.0	1.0x6x26	A231 0100	11.23 €	5.9	5.9x28x66	A231 0590	24.27 €
1.1	1.1x7x28	A231 0110	11.23 €	6.0	6x28x66	A231 0600	24.27 €
1.2	1.2x8x30	A231 0120	10.85 €	6.1	6.1x31x70	A231 0610	30.38 €
1.3	1.3x8x30	A231 0130	10.85 €	6.2	6.2x31x70	A231 0620	30.38 €
1.4	1.4x9x32	A231 0140	10.85 €	6.3	6.3x31x70	A231 0630	30.38 €
1.5	1.5x9x32	A231 0150	10.35 €	6.4	6.4x31x70	A231 0640	30.38 €
1.6	1.6x10x34	A231 0160	10.35 €	6.5	6.5x31x70	A231 0650	29.52 €
1.7	1.7x10x34	A231 0170	10.35 €	6.6	6.6x31x70	A231 0660	35.86 €
1.8	1.8x11x36	A231 0180	10.35 €	6.7	6.7x31x70	A231 0670	35.86 €
1.9	1.9x11x36	A231 0190	10.35 €	6.8	6.8x34x74	A231 0680	35.86 €
2.0	2x12x38	A231 0200	7.54 €	6.9	6.9x34x74	A231 0690	35.86 €
2.1	2.1x12x38	A231 0210	8.41 €	7.0	7.0x34x74	A231 0700	35.50 €
2.2	2.2x13x40	A231 0220	8.41 €	7.1	7.1x34x74	A231 0710	42.99 €
2.3	2.3x13x40	A231 0230	8.41 €	7.2	7.2x34x74	A231 0720	42.99 €
2.4	2.4x14x43	A231 0240	8.41 €	7.3	7.3x34x74	A231 0730	42.99 €
2.5	2.5x14x43	A231 0250	8.41 €	7.4	7.4x34x74	A231 0740	42.99 €
2.6	2.6x14x43	A231 0260	8.41 €	7.5	7.5x34x74	A231 0750	42.68 €
2.7	2.7x16x46	A231 0270	11.16 €	7.6	7.6x37x79	A231 0760	48.53 €
2.8	2.8x16x46	A231 0280	11.16 €	7.7	7.7x37x79	A231 0770	48.53 €
2.9	2.9x16x46	A231 0290	11.16 €	7.8	7.8x37x79	A231 0780	48.53 €
3.0	3x16x46	A231 0300	11.16 €	7.9	7.9x37x79	A231 0790	48.53 €
3.1	3.1x18x49	A231 0310	11.43 €	8.0	8x37x79	A231 0800	47.74 €
3.2	3.2x18x49	A231 0320	11.43 €	8.1	8.1x37x79	A231 0810	59.27 €
3.3	3.3x18x49	A231 0330	11.43 €	8.2	8.2x37x79	A231 0820	59.27 €
3.4	3.4x20x52	A231 0340	12.28 €	8.3	8.3x37x79	A231 0830	59.27 €
3.5	3.5x20x52	A231 0350	12.28 €	8.4	8.4x37x79	A231 0840	59.27 €
3.6	3.6x20x52	A231 0360	13.60 €	8.5	8.5x37x79	A231 0850	60.22 €
3.7	3.7x20x52	A231 0370	13.60 €	8.6	8.6x40x84	A231 0860	64.39 €
3.8	3.8x20x52	A231 0380	14.59 €	8.7	8.7x40x84	A231 0870	64.39 €
3.9	3.9x22x55	A231 0390	14.59 €	8.8	8.8x40x84	A231 0880	64.39 €
4.0	4x22x55	A231 0400	14.59 €	8.9	8.9x40x84	A231 0890	64.39 €
4.1	4.1x22x55	A231 0410	15.35 €	9.0	9x40x84	A231 0900	60.77 €
4.2	4.2x22x55	A231 0420	15.35 €	9.1	9.1x40x84	A231 0910	70.45 €
4.3	4.3x24x58	A231 0430	16.36 €	9.2	9.2x40x84	A231 0920	70.45 €
4.4	4.4x24x58	A231 0440	16.36 €	9.3	9.3x40x84	A231 0930	70.45 €
4.5	4.5x24x58	A231 0450	16.36 €	9.4	9.4x40x84	A231 0940	70.45 €
4.6	4.6x24x58	A231 0460	16.36 €	9.5	9.5x40x84	A231 0950	67.69 €
4.7	4.7x24x58	A231 0470	17.60 €	9.6	9.6x43x89	A231 0960	72.66 €
4.8	4.8x26x62	A231 0480	17.60 €	9.7	9.7x43x89	A231 0970	72.66 €
4.9	4.9x26x62	A231 0490	17.60 €	9.8	9.8x43x89	A231 0980	72.66 €
5.0	5x26x62	A231 0500	17.60 €	9.9	9.9x43x89	A231 0990	72.66 €
5.1	5.1x26x62	A231 0510	17.60 €	10.0	10x43x89	A231 1000	69.43 €
5.2	5.2x26x62	A231 0520	22.83 €	10.2	10.2x43x89	A231 1020	82.36 €
5.3	5.3x26x62	A231 0530	22.83 €	10.5	10.5x43x89	A231 1050	82.36 €
5.4	5.4x28x66	A231 0540	22.83 €	11.0	11x47x95	A231 1100	91.47 €
5.5	5.5x28x66	A231 0550	22.83 €	11.5	11.5x47x95	A231 1150	107.18 €
5.6	5.6x28x66	A231 0560	24.27 €	12.0	12x51x102	A231 1200	107.18 €
5.7	5.7x28x66	A231 0570	24.27 €	13.0	13x51x102	A231 1300	129.82 €
5.8	5.8x28x66	A231 0580	24.27 €				



réf. A232

conditions de coupe recommandées p. 14

Ø perçage	Dimensions	Réf.	Prix unitaire TARIF H.T.	Ø perçage	Dimensions	Réf.	Prix unitaire TARIF H.T.
1.0	1x12x34	A232 0100	11.87 €	4.4	4.4x47x80	A232 0440	27.39 €
1.1	1.1x14x36	A232 0110	11.87 €	4.5	4.5x47x80	A232 0450	24.95 €
1.2	1.2x16x38	A232 0120	11.43 €	4.6	4.6x47x80	A232 0460	28.33 €
1.3	1.3x16x38	A232 0130	11.43 €	4.7	4.7x47x80	A232 0470	28.33 €
1.4	1.4x18x40	A232 0140	11.43 €	4.8	4.8x52x86	A232 0480	29.37 €
1.5	1.5x18x40	A232 0150	10.85 €	4.9	4.9x52x86	A232 0490	29.37 €
1.6	1.6x20x43	A232 0160	10.85 €	5.0	5.0x52x86	A232 0500	27.27 €
1.7	1.7x20x43	A232 0170	10.85 €	5.1	5.1x52x86	A232 0510	33.06 €
1.8	1.8x22x46	A232 0180	10.85 €	5.2	5.2x52x86	A232 0520	33.06 €
1.9	1.9x22x46	A232 0190	10.85 €	5.3	5.3x52x86	A232 0530	33.06 €
2.0	2.0x24x49	A232 0200	9.85 €	5.4	5.4x57x93	A232 0540	37.50 €
2.1	2.1x24x49	A232 0210	11.60 €	5.5	5.5x57x93	A232 0550	36.12 €
2.2	2.2x27x53	A232 0220	12.72 €	5.6	5.6x57x93	A232 0560	39.36 €
2.3	2.3x27x53	A232 0230	12.72 €	5.7	5.7x57x93	A232 0570	39.36 €
2.4	2.4x30x57	A232 0240	12.72 €	5.8	5.8x57x93	A232 0580	39.36 €
2.5	2.5x30x57	A232 0250	12.48 €	5.9	5.9x57x93	A232 0590	39.36 €
2.6	2.6x30x57	A232 0260	16.65 €	6.0	6.0x57x93	A232 0600	38.30 €
2.7	2.7x33x61	A232 0270	16.65 €	6.1	6.1x63x101	A232 0610	48.92 €
2.8	2.8x33x61	A232 0280	16.65 €	6.2	6.2x63x101	A232 0620	48.92 €
2.9	2.9x33x61	A232 0290	16.65 €	6.3	6.3x63x101	A232 0630	48.92 €
3.0	3.0x33x61	A232 0300	16.20 €	6.4	6.4x63x101	A232 0640	48.92 €
3.1	3.1x36x65	A232 0310	16.20 €	6.5	6.5x63x101	A232 0650	47.42 €
3.2	3.2x36x65	A232 0320	16.20 €	6.8	6.8x69x109	A232 0680	57.40 €
3.3	3.3x36x65	A232 0330	16.36 €	7.0	7x69x109	A232 0700	56.89 €
3.4	3.4x39x70	A232 0340	18.09 €	8.0	8.0x75x117	A232 0800	67.69 €
3.5	3.5x39x70	A232 0350	17.72 €	8.5	8.5x75x117	A232 0850	78.80 €
3.6	3.6x39x70	A232 0360	19.14 €	10.0	10.0x87x133	A232 1000	99.31 €
3.7	3.7x39x70	A232 0370	19.14 €	10.2	10.2x87x133	A232 1020	120.10 €
3.8	3.8x43x75	A232 0380	20.34 €	10.5	10.5x87x133	A232 1050	114.03 €
3.9	3.9x43x75	A232 0390	20.34 €	11.0	11x94x142	A232 1100	141.06 €
4.0	4.0x43x75	A232 0400	20.10 €	11.5	11.5x94x142	A232 1150	151.04 €
4.1	4.1x43x75	A232 0410	20.71 €	12.0	12x101x151	A232 1200	163.50 €
4.2	4.2x43x75	A232 0420	20.71 €	13.0	13x101x151	A232 1300	196.13 €
4.3	4.3x47x80	A232 0430	27.39 €				



réf. A202

conditions de coupe recommandées p. 15

Ø perçage	Dimensions	Réf.	Prix unitaire TARIF H.T.	Ø perçage	Dimensions	Réf.	Prix unitaire TARIF H.T.
3.0	3x6x20x62	A202 0300 F	39.93 €	6.9	6.9x8x34x79	A202 0690 F	67.51 €
3.1	3.1x6x20x62	A202 0310 F	39.93 €	7.0	7x8x34x79	A202 0700 F	67.51 €
3.2	3.2x6.0x20x62	A202 0320 F	39.93 €	7.1	7.1x8x41x79	A202 0710 F	67.51 €
3.3	3.3x6x20x62	A202 0330 F	39.93 €	7.2	7.2x8x41x79	A202 0720 F	67.51 €
3.4	3.4x6x20x62	A202 0340 F	39.93 €	7.3	7.3x8x41x79	A202 0730 F	67.51 €
3.5	3.5x6x20x62	A202 0350 F	39.93 €	7.4	7.4x8x41x79	A202 0740 F	67.51 €
3.6	3.6x6x20x62	A202 0360 F	39.93 €	7.5	7.5x8x41x79	A202 0750 F	67.51 €
3.7	3.7x6x20x62	A202 0370 F	39.93 €	7.6	7.6x8x41x79	A202 0760 F	67.51 €
3.8	3.8x6x24x66	A202 0380 F	39.93 €	7.7	7.7x8x41x79	A202 0770 F	67.51 €
3.9	3.9x6x24x66	A202 0390 F	39.93 €	7.8	7.8x8x41x79	A202 0780 F	67.51 €
4.0	4x6x24x66	A202 0400 F	39.93 €	7.9	7.9x8x41x79	A202 0790 F	67.51 €
4.1	4.1x6x24x66	A202 0410 F	39.93 €	8.0	8x8x41x79	A202 0800 F	67.51 €
4.2	4.2x6x24x66	A202 0420 F	39.93 €	8.1	8.1x10x47x89	A202 0810 F	86.23 €
4.3	4.3x6x24x66	A202 0430 F	39.93 €	8.2	8.2x10x47x89	A202 0820 F	86.23 €
4.4	4.4x6x24x66	A202 0440 F	39.93 €	8.3	8.3x10x47x89	A202 0830 F	86.23 €
4.5	4.5x6x24x66	A202 0450 F	39.93 €	8.4	8.4x10x47x89	A202 0840 F	86.23 €
4.6	4.6x6x24x66	A202 0460 F	39.93 €	8.5	8.5x10x47x89	A202 0850 F	86.23 €
4.7	4.7x6x24x66	A202 0470 F	39.93 €	8.6	8.6x10x47x89	A202 0860 F	86.23 €
4.8	4.8x6x28x66	A202 0480 F	39.93 €	8.7	8.7x10x47x89	A202 0870 F	86.23 €
4.9	4.9x6x28x66	A202 0490 F	39.93 €	8.8	8.8x10x47x89	A202 0880 F	86.23 €
5.0	5x6x28x66	A202 0500 F	39.93 €	8.9	8.9x10x47x89	A202 0890 F	86.23 €
5.1	5.1x6x28x66	A202 0510 F	39.93 €	9.0	9x10x47x89	A202 0900 F	86.23 €
5.2	5.2x6x28x66	A202 0520 F	39.93 €	9.1	9.1x10x47x89	A202 0910 F	86.23 €
5.3	5.3x6x28x66	A202 0530 F	39.93 €	9.2	9.2x10x47x89	A202 0920 F	86.23 €
5.4	5.4x6x28x66	A202 0540 F	39.93 €	9.3	9.3x10x47x89	A202 0930 F	86.23 €
5.5	5.5x6x28x66	A202 0550 F	39.93 €	9.4	9.4x10x47x89	A202 0940 F	86.23 €
5.6	5.6x6x28x66	A202 0560 F	39.93 €	9.5	9.5x10x47x89	A202 0950 F	86.23 €
5.7	5.7x6x28x66	A202 0570 F	39.93 €	9.6	9.6x10x47x89	A202 0960 F	86.23 €
5.8	5.8x6x28x66	A202 0580 F	39.93 €	9.7	9.7x10x47x89	A202 0970 F	86.23 €
5.9	5.9x6x28x66	A202 0590 F	39.93 €	9.8	9.8x10x47x89	A202 0980 F	86.23 €
6.0	6x6x28x66	A202 0600 F	39.93 €	9.9	9.9x10x47x89	A202 0990 F	86.23 €
6.1	6.1x8x34x79	A202 0610 F	67.51 €	10.0	10x10x47x89	A202 1000 F	86.23 €
6.2	6.2x8x34x79	A202 0620 F	67.51 €	10.1	10.1x12x55x102	A202 1010 F	114.41 €
6.3	6.3x8x34x79	A202 0630 F	67.51 €	10.2	10.2x12x55x102	A202 1020 F	114.41 €
6.4	6.4x8x34x79	A202 0640 F	67.51 €	10.3	10.3x12x55x102	A202 1030 F	114.41 €
6.5	6.5x8x34x79	A202 0650 F	67.51 €	10.4	10.4x12x55x102	A202 1040 F	114.41 €
6.6	6.6x8x34x79	A202 0660 F	67.51 €	10.5	10.5x12x55x102	A202 1050 F	114.41 €
6.7	6.7x8x34x79	A202 0670 F	67.51 €	10.6	10.6x12x55x102	A202 1060 F	114.41 €
6.8	6.8x8x34x79	A202 0680 F	67.51 €	10.7	10.7x12x55x102	A202 1070 F	114.41 €

voir suite ...

FORETS CARBURE DIN 6537 3XD REVÊTUS TiAlN



réf. A202 suite

conditions de coupe recommandées p. 15

Ø perçage	Dimensions	Réf.	Prix unitaire TARIF H.T.
10.8	10.8x12x55x102	A202 1080 F	114.41 €
10.9	10.9x12x55x102	A202 1090 F	114.41 €
11.0	11x12x55x102	A202 1100 F	114.41 €
11.1	11.1x12x55x102	A202 1110 F	114.41 €
11.2	11.2x12x55x102	A202 1120 F	114.41 €
11.3	11.3x12x55x102	A202 1130 F	114.41 €
11.4	11.4x12x55x102	A202 1140 F	114.41 €
11.5	11.5x12x55x102	A202 1150 F	114.41 €
11.6	11.6x12x55x102	A202 1160 F	114.41 €
11.7	11.7x12x55x102	A202 1170 F	114.41 €
11.8	11.8x12x55x102	A202 1180 F	114.41 €
11.9	11.9x12x55x102	A202 1190 F	114.41 €
12.0	12x12x55x102	A202 1200 F	114.41 €
12.2	12.2x14x60x107	A202 1220 F	178.66 €
12.3	12.3x14x60x107	A202 1230 F	178.66 €
12.5	12.5x14x60x107	A202 1250 F	178.66 €
12.8	12.8x14x60x107	A202 1280 F	178.66 €
13.0	13x14x60x107	A202 1300 F	178.66 €
13.5	13.5x14x60x107	A202 1350 F	178.66 €
13.8	13.8x14x60x107	A202 1380 F	178.66 €
14.0	14x14x60x107	A202 1400 F	178.66 €
14.5	14.5x16x65x115	A202 1450 F	219.41 €
14.8	14.8x16x65x115	A202 1480 F	219.41 €
15.0	15x16x65x115	A202 1500 F	219.41 €
15.5	15.5x16x65x115	A202 1550 F	219.41 €
15.8	15.8x16x65x115	A202 1580 F	219.41 €
16.0	16x16x65x115	A202 1600 F	219.41 €
16.5	16.5x18x73x123	A202 1650 F	268.69 €
16.8	16.8x18x73x123	A202 1680 F	268.69 €
17.0	17x18x73x123	A202 1700 F	268.69 €
17.5	17.5x18x73x123	A202 1750 F	268.69 €
17.8	17.8x18x73x123	A202 1780 F	268.69 €
18.0	18x18x73x123	A202 1800 F	268.69 €
18.5	18.5x20x79x131	A202 1850 F	330.25 €
19.0	19x20x79x131	A202 1900 F	330.25 €
19.5	19.5x20x79x131	A202 1950 F	330.25 €
19.8	19.8x20x79x131	A202 1980 F	330.25 €
20.0	20x20x79x131	A202 2000 F	330.25 €



réf. A203

conditions de coupe recommandées p. 15

Ø perçage	Dimensions	Réf.	Prix unitaire TARIF H.T.	Ø perçage	Dimensions	Réf.	Prix unitaire TARIF H.T.
1.0	1x3x8x55	A203 0100 F	46.17 €	5.5	5.5x6x44x82	A203 0550 F	58.77 €
1.1	1.1x3x12x55	A203 0110 F	46.17 €	5.6	5.6x6x44x82	A203 0560 F	58.77 €
1.2	1.2x3x12x55	A203 0120 F	46.17 €	5.7	5.7x6x44x82	A203 0570 F	58.77 €
1.3	1.3x3x12x55	A203 0130 F	46.17 €	5.8	5.8x6x44x82	A203 0580 F	58.77 €
1.4	1.4x3x12x55	A203 0140 F	46.17 €	5.9	5.9x6x44x82	A203 0590 F	58.77 €
1.5	1.5x3x12x55	A203 0150 F	46.17 €	6.0	6x6x44x82	A203 0600 F	58.77 €
1.6	1.6x3x16x55	A203 0160 F	46.17 €	6.1	6.1x8x53x91	A203 0610 F	72.18 €
1.7	1.7x3x16x55	A203 0170 F	46.17 €	6.2	6.2x8x53x91	A203 0620 F	72.18 €
1.8	1.8x3x16x55	A203 0180 F	46.17 €	6.3	6.3x8x53x91	A203 0630 F	72.18 €
1.9	1.9x3x16x55	A203 0190 F	46.17 €	6.4	6.4x8x53x91	A203 0640 F	72.18 €
2.0	2x4x21x57	A203 0200 F	46.17 €	6.5	6.5x8x53x91	A203 0650 F	72.18 €
2.1	2.1x4x21x57	A203 0210 F	46.17 €	6.6	6.6x8x53x91	A203 0660 F	72.18 €
2.2	2.2x4x21x57	A203 0220 F	46.17 €	6.7	6.7x8x53x91	A203 0670 F	72.18 €
2.3	2.3x4x21x57	A203 0230 F	46.17 €	6.8	6.8x8x53x91	A203 0680 F	72.18 €
2.4	2.4x4x21x57	A203 0240 F	46.17 €	6.9	6.9x8x53x91	A203 0690 F	72.18 €
2.5	2.5x4x21x57	A203 0250 F	46.17 €	7.0	7x8x53x91	A203 0700 F	72.18 €
2.6	2.6x4x21x57	A203 0260 F	46.17 €	7.1	7.1x8x53x91	A203 0710 F	72.18 €
2.7	2.7x4x21x57	A203 0270 F	46.17 €	7.2	7.2x8x53x91	A203 0720 F	72.18 €
2.8	2.8x4x21x57	A203 0280 F	46.17 €	7.3	7.3x8x53x91	A203 0730 F	72.18 €
2.9	2.9x4x21x57	A203 0290 F	46.17 €	7.4	7.4x8x53x91	A203 0740 F	72.18 €
3.0	3x6x28x66	A203 0300 F	58.77 €	7.5	7.5x8x53x91	A203 0750 F	72.18 €
3.1	3.1x6x28x66	A203 0310 F	58.77 €	7.6	7.6x8x53x91	A203 0760 F	72.18 €
3.2	3.2x6x28x66	A203 0320 F	58.77 €	7.7	7.7x8x53x91	A203 0770 F	72.18 €
3.3	3.3x6x28x66	A203 0330 F	58.77 €	7.8	7.8x8x53x91	A203 0780 F	72.18 €
3.4	3.4x6x28x66	A203 0340 F	58.77 €	7.9	7.9x8x53x91	A203 0790 F	72.18 €
3.5	3.5x6x28x66	A203 0350 F	58.77 €	8.0	8x8x53x91	A203 0800 F	72.18 €
3.6	3.6x6x28x66	A203 0360 F	58.77 €	8.1	8.1x10x61x103	A203 0810 F	92.95 €
3.7	3.7x6x28x66	A203 0370 F	58.77 €	8.2	8.2x10x61x103	A203 0820 F	92.95 €
3.8	3.8x6x36x74	A203 0380 F	58.77 €	8.3	8.3x10x61x103	A203 0830 F	92.95 €
3.9	3.9x6x36x74	A203 0390 F	58.77 €	8.4	8.4x10x61x103	A203 0840 F	92.95 €
4.0	4x6x36x74	A203 0400 F	58.77 €	8.5	8.5x10x61x103	A203 0850 F	92.95 €
4.1	4.1x6x36x74	A203 0410 F	58.77 €	8.6	8.6x10x61x103	A203 0860 F	92.95 €
4.2	4.2x6x36x74	A203 0420 F	58.77 €	8.7	8.7x10x61x103	A203 0870 F	92.95 €
4.3	4.3x6x36x74	A203 0430 F	58.77 €	8.8	8.8x10x61x103	A203 0880 F	92.95 €
4.4	4.4x6x36x74	A203 0440 F	58.77 €	8.9	8.9x10x61x103	A203 0890 F	92.95 €
4.5	4.5x6x36x74	A203 0450 F	58.77 €	9.0	9x10x61x103	A203 0900 F	92.95 €
4.6	4.6x6x36x74	A203 0460 F	58.77 €	9.1	9.1x10x61x103	A203 0910 F	92.95 €
4.7	4.7x6x36x74	A203 0470 F	58.77 €	9.2	9.2x10x61x103	A203 0920 F	92.95 €
4.8	4.8x6x44x82	A203 0480 F	58.77 €	9.3	9.3x10x61x103	A203 0930 F	92.95 €
4.9	4.9x6x44x82	A203 0490 F	58.77 €	9.4	9.4x10x61x103	A203 0940 F	92.95 €
5.0	5x6x44x82	A203 0500 F	58.77 €	9.5	9.5x10x61x103	A203 0950 F	92.95 €
5.1	5.1x6x44x82	A203 0510 F	58.77 €	9.6	9.6x10x61x103	A203 0960 F	92.95 €
5.2	5.2x6x44x82	A203 0520 F	58.77 €	9.7	9.7x10x61x103	A203 0970 F	92.95 €
5.3	5.3x6x44x82	A203 0530 F	58.77 €	9.8	9.8x10x61x103	A203 0980 F	92.95 €
5.4	5.4x6x44x82	A203 0540 F	58.77 €	9.9	9.9x10x61x103	A203 0990 F	92.95 €

voir suite ...

FORETS CARBURE DIN 6537 5XD REVÊTUS TiAlN



réf. A203 suite

conditions de coupe recommandées p. 15

Ø perçage	Dimensions	Réf.	Prix unitaire TARIF H.T.
10.0	10x10x61x103	A203 1000 F	92.95 €
10.1	10.1x12x71x118	A203 1010 F	152.59 €
10.2	10.2x12x71x118	A203 1020 F	152.59 €
10.3	10.3x12x71x118	A203 1030 F	152.59 €
10.4	10.4x12x71x118	A203 1040 F	152.59 €
10.5	10.5x12x71x118	A203 1050 F	152.59 €
10.6	10.6x12x71x118	A203 1060 F	152.59 €
10.7	10.7x12x71x118	A203 1070 F	152.59 €
10.8	10.8x12x71x118	A203 1080 F	152.59 €
10.9	10.9x12x71x118	A203 1090 F	152.59 €
11.0	11x12x71x118	A203 1100 F	152.59 €
11.1	11.1x12x71x118	A203 1110 F	152.59 €
11.2	11.2x12x71x118	A203 1120 F	152.59 €
11.3	11.3x12x71x118	A203 1130 F	152.59 €
11.4	11.4x12x71x118	A203 1140 F	152.59 €
11.5	11.5x12x71x118	A203 1150 F	152.59 €
11.6	11.6x12x71x118	A203 1160 F	152.59 €
11.7	11.7x12x71x118	A203 1170 F	152.59 €
11.8	11.8x12x71x118	A203 1180 F	152.59 €
11.9	11.9x12x71x118	A203 1190 F	152.59 €
12.0	12x12x71x118	A203 1200 F	152.59 €
12.3	12.3x14x77x124	A203 1230 F	180.78 €
12.5	12.5x14x77x124	A203 1250 F	180.78 €
12.8	12.8x14x77x124	A203 1280 F	180.78 €
13.0	13x14x77x124	A203 1300 F	180.78 €
13.5	13.5x14x77x124	A203 1350 F	180.78 €
13.8	13.8x14x77x124	A203 1380 F	180.78 €
14.0	14x14x77x124	A203 1400 F	180.78 €
14.5	14.5x16x83x133	A203 1450 F	227.64 €
14.8	14.8x16x83x133	A203 1480 F	227.64 €
15.0	15x16x83x133	A203 1500 F	227.64 €
15.5	15.5x16x83x133	A203 1550 F	227.64 €
15.8	15.8x16x83x133	A203 1580 F	227.64 €
16.0	16x16x93x133	A203 1600 F	227.64 €
16.5	16.5x18x93x143	A203 1650 F	288.53 €
16.8	16.8x18x93x143	A203 1680 F	288.53 €
17.0	17x18x93x143	A203 1700 F	288.53 €
17.5	17.5x18x93x143	A203 1750 F	288.53 €
17.8	17.8x18x93x143	A203 1780 F	288.53 €
18.0	18x18x93x143	A203 1800 F	288.53 €
18.5	18.5x20x101x153	A203 1850 F	361.84 €
19.0	19x20x101x153	A203 1900 F	361.84 €
19.5	19.5x20x101x153	A203 1950 F	361.84 €
19.8	19.8x20x101x153	A203 1980 F	361.84 €
20.0	20x20x101x153	A203 2000 F	361.84 €



réf. A204

conditions de coupe recommandées p. 15

Ø perçage	Dimensions	Réf.	Prix unitaire TARIF H.T.	Ø perçage	Dimensions	Réf.	Prix unitaire TARIF H.T.
3.0	3x6x20x62	A204 0300 F	70.37 €	6.6	6.6x8x34x79	A204 0660 F	95.58 €
3.1	3.1x6.0x20x62	A204 0310 F	70.37 €	6.7	6.7x8x34x79	A204 0670 F	95.58 €
3.2	3.2x6x20x62	A204 0320 F	70.37 €	6.8	6.8x8x34x79	A204 0680 F	95.58 €
3.3	3.3x6x20x62	A204 0330 F	70.37 €	6.9	6.9x8x34x79	A204 0690 F	95.58 €
3.4	3.4x6x20x62	A204 0340 F	70.37 €	7.0	7x8x34x79	A204 0700 F	95.58 €
3.5	3.5x6x20x62	A204 0350 F	70.37 €	7.1	7.1x8x41x79	A204 0710 F	95.58 €
3.6	3.6x6x20x62	A204 0360 F	70.37 €	7.2	7.2x8x41x79	A204 0720 F	95.58 €
3.7	3.7x6x20x62	A204 0370 F	70.37 €	7.3	7.3x8x41x79	A204 0730 F	95.58 €
3.8	3.8x6x24x66	A204 0380 F	70.37 €	7.4	7.4x8x41x79	A204 0740 F	95.58 €
3.9	3.9x6x24x66	A204 0390 F	70.37 €	7.5	7.5x8x41x79	A204 0750 F	95.58 €
4.0	4x6x24x66	A204 0400 F	70.37 €	7.6	7.6x8x41x79	A204 0760 F	95.58 €
4.1	4.1x6x24x66	A204 0410 F	70.37 €	7.7	7.7x8x41x79	A204 0770 F	95.58 €
4.2	4.2x6x24x66	A204 0420 F	70.37 €	7.8	7.8x8x41x79	A204 0780 F	95.58 €
4.3	4.3x6x24x66	A204 0430 F	70.37 €	7.9	7.9x8x41x79	A204 0790 F	95.58 €
4.4	4.4x6x24x66	A204 0440 F	70.37 €	8.0	8x8x41x79	A204 0800 F	95.58 €
4.5	4.5x6x24x66	A204 0450 F	70.37 €	8.1	8.1x10x47x89	A204 0810 F	107.03 €
4.6	4.6x6x24x66	A204 0460 F	70.37 €	8.2	8.2x10x47x89	A204 0820 F	107.03 €
4.7	4.7x6x24x66	A204 0470 F	70.37 €	8.3	8.3x10x47x89	A204 0830 F	107.03 €
4.8	4.8x6x28x66	A204 0480 F	70.37 €	8.4	8.4x10x47x89	A204 0840 F	107.03 €
4.9	4.9x6x28x66	A204 0490 F	70.37 €	8.5	8.5x10x47x89	A204 0850 F	107.03 €
5.0	5x6x28x66	A204 0500 F	70.37 €	8.6	8.6x10x47x89	A204 0860 F	107.03 €
5.1	5.1x6x28x66	A204 0510 F	70.37 €	8.7	8.7x10x47x89	A204 0870 F	107.03 €
5.2	5.2x6x28x66	A204 0520 F	70.37 €	8.8	8.8x10x47x89	A204 0880 F	107.03 €
5.3	5.3x6x28x66	A204 0530 F	70.37 €	8.9	8.9x10x47x89	A204 0890 F	107.03 €
5.4	5.4x6x28x66	A204 0540 F	70.37 €	9.0	9x10x47x89	A204 0900 F	107.03 €
5.5	5.5x6x28x66	A204 0550 F	70.37 €	9.1	9.1x10x47x89	A204 0910 F	107.03 €
5.6	5.6x6x28x66	A204 0560 F	70.37 €	9.2	9.2x10x47x89	A204 0920 F	107.03 €
5.7	5.7x6x28x66	A204 0570 F	70.37 €	9.3	9.3x10x47x89	A204 0930 F	107.03 €
5.8	5.8x6x28x66	A204 0580 F	70.37 €	9.4	9.4x10x47x89	A204 0940 F	107.03 €
5.9	5.9x6x28x66	A204 0590 F	70.37 €	9.5	9.5x10x47x89	A204 0950 F	107.03 €
6.0	6x6x28x66	A204 0600 F	70.37 €	9.6	9.6x10x47x89	A204 0960 F	107.03 €
6.1	6.1x8x34x79	A204 0610 F	95.58 €	9.7	9.7x10x47x89	A204 0970 F	107.03 €
6.2	6.2x8x34x79	A204 0620 F	95.58 €	9.8	9.8x10x47x89	A204 0980 F	107.03 €
6.3	6.3x8x34x79	A204 0630 F	95.58 €	9.9	9.9x10x47x89	A204 0990 F	107.03 €
6.4	6.4x8x34x79	A204 0640 F	95.58 €	10.0	10x10x47x89	A204 1000 F	107.03 €
6.5	6.5x8x34x79	A204 0650 F	95.58 €	10.1	10.1x12x55x102	A204 1010 F	153.29 €

voir suite ...

FORETS CARBURE DIN 6537 3XD REVÊTUS TiAIN AVEC ARROSAGE



réf. A204 *suite*

conditions de coupe recommandées p. 15

Ø perçage	Dimensions	Réf.	Prix unitaire TARIF H.T.
10.2	10.2x12x55x102	A204 1020 F	153.29 €
10.3	10.3x12x55x102	A204 1030 F	153.29 €
10.4	10.4x12x55x102	A204 1040 F	153.29 €
10.5	10.5x12x55x102	A204 1050 F	153.29 €
10.6	10.6x12x55x102	A204 1060 F	153.29 €
10.7	10.7x12x55x102	A204 1070 F	153.29 €
10.8	10.8x12x55x102	A204 1080 F	153.29 €
10.9	10.9x12x55x102	A204 1090 F	153.29 €
11.0	11x12x55x102	A204 1100 F	153.29 €
11.1	11.1x12x55x102	A204 1110 F	153.29 €
11.2	11.2x12x55x102	A204 1120 F	153.29 €
11.3	11.3x12x55x102	A204 1130 F	153.29 €
11.4	11.4x12x55x102	A204 1140 F	153.29 €
11.5	11.5x12x55x102	A204 1150 F	153.29 €
11.6	11.6x12x55x102	A204 1160 F	153.29 €
11.7	11.7x12x55x102	A204 1170 F	153.29 €
11.8	11.8x12x55x102	A204 1180 F	153.29 €
11.9	11.9x12x55x102	A204 1190 F	153.29 €
12.0	12x12x55x102	A204 1200 F	153.29 €
12.5	12.5x14x60x107	A204 1250 F	214.22 €
13.0	13x14x60x107	A204 1300 F	214.22 €
13.5	13.5x14x60x107	A204 1350 F	214.22 €
14.0	14x14x60x107	A204 1400 F	214.22 €
14.5	14.5x16x65x115	A204 1450 F	270.00 €
15.0	15x16x65x115	A204 1500 F	270.00 €
15.5	15.5x16x65x115	A204 1550 F	270.00 €
16.0	16x16x65x115	A204 1600 F	270.00 €
16.5	16.5x18x73x123	A204 1650 F	443.31 €
17.0	17x18x73x123	A204 1700 F	443.31 €
17.5	17.5x18x73x123	A204 1750 F	443.31 €
18.0	18x18x73x123	A204 1800 F	443.31 €
18.5	18.5x20x79x131	A204 1850 F	484.30 €
19.0	19x20x79x131	A204 1900 F	484.30 €
19.5	19.5x20x79x131	A204 1950 F	484.30 €
20.0	20x20x79x131	A204 2000 F	484.30 €



réf. A205

conditions de coupe recommandées p. 15

Ø perçage	Dimensions	Réf.	Prix unitaire TARIF H.T.	Ø perçage	Dimensions	Réf.	Prix unitaire TARIF H.T.
1.0	1x3x8x55	A205 0100 F	81.41 €	5.3	5.3x6x44x82	A205 0530 F	90.27 €
1.1	1.1x3x12x55	A205 0110 F	81.41 €	5.4	5.4x6x44x82	A205 0540 F	90.27 €
1.2	1.2x3x12x55	A205 0120 F	81.41 €	5.5	5.5x6x44x82	A205 0550 F	90.27 €
1.3	1.3x3x12x55	A205 0130 F	81.41 €	5.6	5.6x6x44x82	A205 0560 F	90.27 €
1.4	1.4x3x12x55	A205 0140 F	81.41 €	5.7	5.7x6x44x82	A205 0570 F	90.27 €
1.5	1.5x3x16x55	A205 0150 F	81.41 €	5.8	5.8x6x44x82	A205 0580 F	90.27 €
1.6	1.6x3x16x55	A205 0160 F	81.41 €	5.9	5.9x6x44x82	A205 0590 F	90.27 €
1.7	1.7x3x16x55	A205 0170 F	81.41 €	6.0	6x6x44x82	A205 0600 F	90.27 €
1.8	1.8x3x16x55	A205 0180 F	81.41 €	6.1	6.1x8x53x91	A205 0610 F	99.75 €
1.9	1.9x3x16x55	A205 0190 F	81.41 €	6.2	6.2x8x53x91	A205 0620 F	99.75 €
2.0	2x4x21x57	A205 0200 F	81.41 €	6.3	6.3x8x53x91	A205 0630 F	99.75 €
2.1	2.1x4x21x57	A205 0210 F	81.41 €	6.4	6.4x8x53x91	A205 0640 F	99.75 €
2.2	2.2x4x21x57	A205 0220 F	81.41 €	6.5	6.5x8x53x91	A205 0650 F	99.75 €
2.3	2.3x4x21x57	A205 0230 F	81.41 €	6.6	6.6x8x53x91	A205 0660 F	99.75 €
2.4	2.4x4x21x57	A205 0240 F	81.41 €	6.7	6.7x8x53x91	A205 0670 F	99.75 €
2.5	2.5x4x21x57	A205 0250 F	81.41 €	6.8	6.8x8x53x91	A205 0680 F	99.75 €
2.6	2.6x4x21x57	A205 0260 F	81.41 €	6.9	6.9x8x53x91	A205 0690 F	99.75 €
2.7	2.7x4x21x57	A205 0270 F	81.41 €	7.0	7x8x53x91	A205 0700 F	99.75 €
2.8	2.8x4x21x57	A205 0280 F	81.41 €	7.1	7.1x8x53x91	A205 0710 F	99.75 €
2.9	2.9x4x21x57	A205 0290 F	81.41 €	7.2	7.2x8x53x91	A205 0720 F	99.75 €
3.0	3x6x28x66	A205 0300 F	90.27 €	7.3	7.3x8x53x91	A205 0730 F	99.75 €
3.1	3.1x6x28x66	A205 0310 F	90.27 €	7.4	7.4x8x53x91	A205 0740 F	99.75 €
3.2	3.2x6x28x66	A205 0320 F	90.27 €	7.5	7.5x8x53x91	A205 0750 F	99.75 €
3.3	3.3x6x28x66	A205 0330 F	90.27 €	7.6	7.6x8x53x91	A205 0760 F	99.75 €
3.4	3.4x6x28x66	A205 0340 F	90.27 €	7.7	7.7x8x53x91	A205 0770 F	99.75 €
3.5	3.5x6x28x66	A205 0350 F	90.27 €	7.8	7.8x8x53x91	A205 0780 F	99.75 €
3.6	3.6x6x28x66	A205 0360 F	90.27 €	7.9	7.9x8x53x91	A205 0790 F	99.75 €
3.7	3.7x6x28x66	A205 0370 F	90.27 €	8.0	8x8x53x91	A205 0800 F	99.75 €
3.8	3.8x6x36x74	A205 0380 F	90.27 €	8.1	8.1x10x61x103	A205 0810 F	118.79 €
3.9	3.9x6x36x74	A205 0390 F	90.27 €	8.2	8.2x10x61x103	A205 0820 F	118.79 €
4.0	4x6x36x74	A205 0400 F	90.27 €	8.3	8.3x10x61x103	A205 0830 F	118.79 €
4.1	4.1x6x36x74	A205 0410 F	90.27 €	8.4	8.4x10x61x103	A205 0840 F	118.79 €
4.2	4.2x6x36x74	A205 0420 F	90.27 €	8.5	8.5x10x61x103	A205 0850 F	118.79 €
4.3	4.3x6x36x74	A205 0430 F	90.27 €	8.6	8.6x10x61x103	A205 0860 F	118.79 €
4.4	4.4x6x36x74	A205 0440 F	90.27 €	8.7	8.7x10x61x103	A205 0870 F	118.79 €
4.5	4.5x6x36x74	A205 0450 F	90.27 €	8.8	8.8x10x61x103	A205 0880 F	118.79 €
4.6	4.6x6x36x74	A205 0460 F	90.27 €	8.9	8.9x10x61x103	A205 0890 F	118.79 €
4.7	4.7x6x36x74	A205 0470 F	90.27 €	9.0	9x10x61x103	A205 0900 F	118.79 €
4.8	4.8x6x44x82	A205 0480 F	90.27 €	9.1	9.1x10x61x103	A205 0910 F	118.79 €
4.9	4.9x6x44x82	A205 0490 F	90.27 €	9.2	9.2x10x61x103	A205 0920 F	118.79 €
5.0	5x6x44x82	A205 0500 F	90.27 €	9.3	9.3x10x61x103	A205 0930 F	118.79 €
5.1	5.1x6x44x82	A205 0510 F	90.27 €	9.4	9.4x10x61x103	A205 0940 F	118.79 €
5.2	5.2x6x44x82	A205 0520 F	90.27 €	9.5	9.5x10x61x103	A205 0950 F	118.79 €

voir suite ...

FORETS CARBURE DIN 6537 5XD REVÊTUS TiAIN AVEC ARROSAGE



réf. A205 suite

conditions de coupe recommandées p. 15

Ø perçage	Dimensions	Réf.	Prix unitaire TARIF H.T.
9.6	9.6x10x61x103	A205 0960 F	118.79 €
9.7	9.7x10x61x103	A205 0970 F	118.79 €
9.8	9.8x10x61x103	A205 0980 F	118.79 €
9.9	9.9x10x61x103	A205 0990 F	118.79 €
10.0	10x10x61x103	A205 1000 F	118.79 €
10.1	10.1x12x71x118	A205 1010 F	166.95 €
10.2	10.2x12x71x118	A205 1020 F	166.95 €
10.3	10.3x12x71x118	A205 1030 F	166.95 €
10.4	10.4x12x71x118	A205 1040 F	166.95 €
10.5	10.5x12x71x118	A205 1050 F	166.95 €
10.6	10.6x12x71x118	A205 1060 F	166.95 €
10.7	10.7x12x71x118	A205 1070 F	166.95 €
10.8	10.8x12x71x118	A205 1080 F	166.95 €
10.9	10.9x12x71x118	A205 1090 F	166.95 €
11.0	11x12x71x118	A205 1100 F	166.95 €
11.1	11.1x12x71x118	A205 1110 F	166.95 €
11.2	11.2x12x71x118	A205 1120 F	166.95 €
11.3	11.3x12x71x118	A205 1130 F	166.95 €
11.4	11.4x12x71x118	A205 1140 F	166.95 €
11.5	11.5x12x71x118	A205 1150 F	166.95 €
11.6	11.6x12x71x118	A205 1160 F	166.95 €
11.7	11.7x12x71x118	A205 1170 F	166.95 €
11.8	11.8x12x71x118	A205 1180 F	166.95 €
11.9	11.9x12x71x118	A205 1190 F	166.95 €
12.0	12x12x71x118	A205 1200 F	166.95 €
12.5	12.5x14x77x124	A205 1250 F	237.19 €
13.0	13x14x77x124	A205 1300 F	237.19 €
13.5	13.5x14x77x124	A205 1350 F	237.19 €
14.0	14x14x77x124	A205 1400 F	237.19 €
14.5	14.5x16x83x133	A205 1450 F	313.49 €
15.0	15x16x83x133	A205 1500 F	313.49 €
15.5	15.5x16x83x133	A205 1550 F	313.49 €
16.0	16x16x83x133	A205 1600 F	313.49 €
16.5	16.5x18x93x143	A205 1650 F	468.81 €
17.0	17x18x93x143	A205 1700 F	468.81 €
17.5	17.5x18x93x143	A205 1750 F	468.81 €
18.0	18x18x93x143	A205 1800 F	468.81 €
18.5	18.5x20x101x153	A205 1850 F	536.69 €
19.0	19x20x101x153	A205 1900 F	536.69 €
19.5	19.5x20x101x153	A205 1950 F	536.69 €
20.0	20x20x101x153	A205 2000 F	536.69 €



réf. A206

conditions de coupe recommandées p. 15

Ø perçage	Dimensions	Réf.	Prix unitaire TARIF H.T.	Ø perçage	Dimensions	Réf.	Prix unitaire TARIF H.T.
3.0	3x6x34x72	A206 0300 F	167.88 €	7.7	7.7x8x76x114	A206 0770 F	182.71 €
3.1	3.1x6x34x72	A206 0310 F	167.88 €	7.8	7.8x8x76x114	A206 0780 F	182.71 €
3.2	3.2x6x34x72	A206 0320 F	167.88 €	7.9	7.9x8x76x114	A206 0790 F	182.71 €
3.3	3.3x6x34x72	A206 0330 F	167.88 €	8.0	8x8x76x114	A206 0800 F	182.71 €
3.4	3.4x6x34x72	A206 0340 F	167.88 €	8.1	8.1x10x95x142	A206 0810 F	250.24 €
3.5	3.5x6x34x72	A206 0350 F	167.88 €	8.2	8.2x10x95x142	A206 0820 F	250.24 €
3.6	3.6x6x34x72	A206 0360 F	167.88 €	8.3	8.3x10x95x142	A206 0830 F	250.24 €
3.7	3.7x6x34x72	A206 0370 F	167.88 €	8.4	8.4x10x95x142	A206 0840 F	250.24 €
3.8	3.8x6x43x81	A206 0380 F	167.88 €	8.5	8.5x10x95x142	A206 0850 F	250.24 €
3.9	3.9x6x43x81	A206 0390 F	167.88 €	8.6	8.6x10x95x142	A206 0860 F	250.24 €
4.0	4x6x43x81	A206 0400 F	167.88 €	8.7	8.7x10x95x142	A206 0870 F	250.24 €
4.1	4.1x6x43x81	A206 0410 F	167.88 €	8.8	8.8x10x95x142	A206 0880 F	250.24 €
4.2	4.2x6x43x81	A206 0420 F	167.88 €	8.9	8.9x10x95x142	A206 0890 F	250.24 €
4.3	4.3x6x43x81	A206 0430 F	167.88 €	9.0	9x10x95x142	A206 0900 F	250.24 €
4.4	4.4x6x43x81	A206 0440 F	167.88 €	9.1	9.1x10x95x142	A206 0910 F	250.24 €
4.5	4.5x6x43x81	A206 0450 F	167.88 €	9.2	9.2x10x95x142	A206 0920 F	250.24 €
4.6	4.6x6x43x81	A206 0460 F	167.88 €	9.3	9.3x10x95x142	A206 0930 F	250.24 €
4.7	4.7x6x43x81	A206 0470 F	167.88 €	9.4	9.4x10x95x142	A206 0940 F	250.24 €
4.8	4.8x6x57x95	A206 0480 F	167.88 €	9.5	9.5x10x95x142	A206 0950 F	250.24 €
4.9	4.9x6x57x95	A206 0490 F	167.88 €	9.6	9.6x10x95x142	A206 0960 F	250.24 €
5.0	5x6x57x95	A206 0500 F	167.88 €	9.7	9.7x10x95x142	A206 0970 F	250.24 €
5.1	5.1x6x57x95	A206 0510 F	167.88 €	9.8	9.8x10x95x142	A206 0980 F	250.24 €
5.2	5.2x6x57x95	A206 0520 F	167.88 €	9.9	9.9x10x95x142	A206 0990 F	250.24 €
5.3	5.3x6x57x95	A206 0530 F	167.88 €	10.0	10x10x95x142	A206 1000 F	250.24 €
5.4	5.4x6x57x95	A206 0540 F	167.88 €	10.1	10.1x12x114x162	A206 1010 F	332.13 €
5.5	5.5x6x57x95	A206 0550 F	167.88 €	10.2	10.2x12x114x162	A206 1020 F	332.13 €
5.6	5.6x6x57x95	A206 0560 F	167.88 €	10.3	10.3x12x114x162	A206 1030 F	332.13 €
5.7	5.7x6x57x95	A206 0570 F	167.88 €	10.4	10.4x12x114x162	A206 1040 F	332.13 €
5.8	5.8x6x57x95	A206 0580 F	167.88 €	10.5	10.5x12x114x162	A206 1050 F	332.13 €
5.9	5.9x6x57x95	A206 0590 F	167.88 €	10.6	10.6x12x114x162	A206 1060 F	332.13 €
6.0	6x6x57x95	A206 0600 F	167.88 €	10.7	10.7x12x114x162	A206 1070 F	332.13 €
6.1	6.1x8x76x114	A206 0610 F	182.71 €	10.8	10.8x12x114x162	A206 1080 F	332.13 €
6.2	6.2x8x76x114	A206 0620 F	182.71 €	10.9	10.9x12x114x162	A206 1090 F	332.13 €
6.3	6.3x8x76x114	A206 0630 F	182.71 €	11.0	11x12x114x162	A206 1100 F	332.13 €
6.4	6.4x8x76x114	A206 0640 F	182.71 €	11.1	11.1x12x114x162	A206 1110 F	332.13 €
6.5	6.5x8x76x114	A206 0650 F	182.71 €	11.2	11.2x12x114x162	A206 1120 F	332.13 €
6.6	6.6x8x76x114	A206 0660 F	182.71 €	11.3	11.3x12x114x162	A206 1130 F	332.13 €
6.7	6.7x8x76x114	A206 0670 F	182.71 €	11.4	11.4x12x114x162	A206 1140 F	332.13 €
6.8	6.8x8x76x114	A206 0680 F	182.71 €	11.5	11.5x12x114x162	A206 1150 F	332.13 €
6.9	6.9x8x76x114	A206 0690 F	182.71 €	11.6	11.6x12x114x162	A206 1160 F	332.13 €
7.0	7x8x76x114	A206 0700 F	182.71 €	11.7	11.7x12x114x162	A206 1170 F	332.13 €
7.1	7.1x8x76x114	A206 0710 F	182.71 €	11.8	11.8x12x114x162	A206 1180 F	332.13 €
7.2	7.2x8x76x114	A206 0720 F	182.71 €	11.9	11.9x12x114x162	A206 1190 F	332.13 €
7.3	7.3x8x76x114	A206 0730 F	182.71 €	12.0	12x12x114x162	A206 1200 F	332.13 €
7.4	7.4x8x76x114	A206 0740 F	182.71 €	13.0	13x14x133x178	A206 1300 F	405.73 €
7.5	7.5x8x76x114	A206 0750 F	182.71 €	14.0	14x14x133x178	A206 1400 F	405.73 €
7.6	7.6x8x76x114	A206 0760 F	182.71 €				

FORETS CARBURE À POINTER NC 90° ET 120°



réf. A233 Forets carbure à pointer NC 90°

réf. A234 Forets carbure à pointer NC 120°

Ø perçage	Dimensions	Réf.	Prix unitaire TARIF H.T.
6.0	6x13x50	A233 0600 M	35.38 €
8.0	8x23x60	A233 0800 M	49.98 €
10.0	10x24x70	A233 1000 M	70.94 €
12.0	12x24x70	A233 1200 M	91.76 €
16.0	16x29x75	A233 1600 M	169.06 €
20.0	20x35x100	A233 2000 M	300.25 €

Ø perçage	Dimensions	Réf.	Prix unitaire TARIF H.T.
6.0	6x13x50	A234 0600 M	35.38 €
8.0	8x23x60	A234 0800 M	49.98 €
10.0	10x24x70	A234 1000 M	70.94 €
12.0	12x24x70	A234 1200 M	91.76 €
16.0	16x29x75	A234 1600 M	169.06 €
20.0	20x35x100	A234 2000 M	300.25 €

Conditions de coupe recommandées

unité = mm

Matière usinée	Aciers non-alliés		Aciers alliés		Fontes grises ductiles		Fontes grises dures		Aciers inox		Alu Si<10%		Alu Si>10%		Alliages Ti, Ni	
	N	S	N	S	N	S	N	S	N	S	N	S	N	S	N	S
RESISTANCE	< 700 N/mm2		< 1000 N/mm2		< HB240, GG25		< HB300, GG40									
DIAMETRE	N	S	N	S	N	S	N	S	N	S	N	S	N	S	N	S
6	3 900	0.08	2 850	0.08	5 200	0.09	3 800	0.09	2 000	0.07	8 800	0.11	7 100	0.11	1 950	0.07
8	2 900	0.10	2 150	0.10	3 900	0.12	2 850	0.12	1 500	0.09	6 600	0.15	5 350	0.15	1 450	0.09
10	2 350	0.12	1 700	0.12	3 100	0.16	2 300	0.16	1 200	0.11	5 300	0.19	4 250	0.19	1 200	0.11
12	1 950	0.14	1 450	0.14	2 600	0.20	1 900	0.20	1 000	0.13	4 450	0.23	3 550	0.23	980	0.13
16	1 450	0.17	1 100	0.17	1 950	0.24	1 450	0.24	755	0.17	3 300	0.27	2 650	0.27	735	0.17
20	1 150	0.19	850	0.19	1 550	0.28	1 150	0.28	590	0.20	2 650	0.31	2 150	0.31	590	0.20

N = R.P.M.

S = Avance par tour (mm/tr)

FORETS CARBURE, DIN338 & DIN6539

ref. A231, A232

unité = mm

Matière usinée	Aciers non-alliés		Aciers alliés		Fontes grises ductiles		Fontes grises dures		Aciers inox		Alu Si<10%		Alu Si>10%		Alliages Ti, Ni	
	N	S	N	S	N	S	N	S	N	S	N	S	N	S	N	S
RESISTANCE	< 700 N/mm2		< 1000 N/mm2		< HB240, GG25		< HB300, GG40									
DIAMETRE																
1	23 000	0.03	17 200	0.03	32 000	0.04	23 000	0.04	12 000	0.04	54 000	0.05	42 000	0.05	11 800	0.02
2	11 500	0.04	8 600	0.04	16 000	0.05	11 500	0.05	6 000	0.03	27 000	0.06	21 000	0.06	5 900	0.03
3	7 800	0.05	5 750	0.05	10 500	0.06	7 600	0.06	4 000	0.04	18 000	0.07	14 000	0.07	3 900	0.04
4	5 800	0.06	4 300	0.06	7 800	0.07	5 700	0.07	3 000	0.05	13 000	0.08	10 500	0.08	2 950	0.05
5	4 700	0.07	3 450	0.07	6 200	0.08	4 550	0.08	2 400	0.06	10 500	0.09	8 500	0.09	2 350	0.06
6	3 900	0.08	2 850	0.08	5 200	0.09	3 800	0.09	2 000	0.07	8 800	0.11	7 100	0.11	1 950	0.07
7	3 350	0.09	2 450	0.09	4 500	0.10	3 250	0.10	1 700	0.08	7 600	0.13	6 100	0.13	1 700	0.08
8	2 900	0.10	2 150	0.10	3 900	0.12	2 850	0.12	1 500	0.09	6 600	0.15	5 350	0.15	1 450	0.09
9	2 600	0.11	1 900	0.11	3 450	0.14	2 550	0.14	1 350	0.10	5 900	0.17	4 750	0.17	1 300	0.10
10	2 350	0.12	1 700	0.12	3 100	0.16	2 300	0.16	1 200	0.11	5 300	0.19	4 250	0.19	1 200	0.11
11	2 150	0.13	1 600	0.13	2 850	0.18	2 100	0.18	1 100	0.12	4 850	0.21	3 900	0.21	1 050	0.12
12	1 950	0.14	1 450	0.14	2 600	0.20	1 900	0.20	1 000	0.13	4 450	0.23	3 550	0.23	980	0.13
13	1 800	0.16	1 350	0.16	2 400	0.20	1 750	0.20	950	0.13	4 100	0.25	3 300	0.25	905	0.13

N = R.P.M.

S = Avance par tour (mm/tr)

FORETS CARBURE - DIN 6537, REVETEMENT TiAlN

ref. A202, A203, DIN 6537

Matière usinée	Aciers non-alliés		Aciers alliés		Fontes grises ductiles		Fontes grises dures	
	< 700 N/mm ²		< 1000 N/mm ²		< HB240, GG25		< HB300, GG40	
RESISTANCE								
DIAMETRE	N	S	N	S	N	S	N	S
1	13 000	0.04	11 250	0.04	21 300	0.04	14 200	0.04
2	13 000	0.06	11 250	0.06	21 300	0.06	14 200	0.06
3	13 000	0.13	11 000	0.13	21 000	0.13	14 000	0.13
4	9 500	0.14	8 400	0.14	16 000	0.14	10 500	0.14
5	7 600	0.15	6 700	0.15	13 000	0.15	8 300	0.15
6	6 400	0.17	5 600	0.17	11 000	0.17	6 900	0.17
7	5 500	0.19	4 800	0.19	9 100	0.19	5 900	0.19
8	4 800	0.21	4 200	0.21	8 000	0.21	5 200	0.21
9	4 200	0.23	3 700	0.23	7 100	0.23	4 600	0.23
10	3 800	0.25	3 350	0.25	6 400	0.25	4 150	0.25
12	3 200	0.27	2 800	0.27	5 300	0.27	3 450	0.27
14	2 750	0.29	2 400	0.29	4 550	0.29	3 000	0.29
16	2 400	0.31	2 100	0.31	4 000	0.31	2 600	0.31
18	2 100	0.33	1 850	0.33	3 550	0.33	2 300	0.33
20	1 900	0.35	1 650	0.35	3 200	0.35	2 100	0.35

Il est recommandé de réduire l'avance comme suit :

Avance 100 % : A202 (3XD)

Avance 85 % : A203 (5XD)

N = R.P.M.

S = Avance par tour (mm/tr)

FORETS CARBURE avec ARROSAGE CENTRAL - DIN 6537, REVETEMENT TiAlN

ref. A204, A205, A206

Matière usinée	Aciers non-alliés		Aciers alliés		Fontes grises ductiles		Fontes grises dures	
	< 700 N/mm ²		< 1000 N/mm ²		< HB240, GG25		< HB300, GG40	
RESISTANCE								
DIAMETRE	N	S	N	S	N	S	N	S
1	16 250	0.05	14 800	0.05	26 600	0.05	17 300	0.05
2	16 250	0.07	14 800	0.07	26 600	0.07	17 300	0.07
3	16 000	0.16	14 500	0.16	26 000	0.16	17 000	0.16
4	12 000	0.17	11 000	0.17	20 000	0.17	13 000	0.17
5	9 550	0.18	8 600	0.18	16 000	0.18	10 000	0.18
6	8 000	0.20	7 200	0.20	13 000	0.20	8 500	0.20
7	6 800	0.22	6 100	0.22	11 500	0.22	7 300	0.22
8	6 000	0.24	5 400	0.24	9 900	0.24	6 400	0.24
9	5 300	0.27	4 800	0.27	8 800	0.27	5 700	0.27
10	4 800	0.30	4 300	0.30	8 000	0.30	5 100	0.30
12	4 000	0.33	3 600	0.33	6 600	0.33	4 250	0.33
14	3 400	0.36	3 050	0.36	5 700	0.36	3 650	0.36
16	3 000	0.39	2 700	0.39	5 000	0.39	3 200	0.39
18	2 650	0.42	2 400	0.42	4 400	0.42	2 850	0.42
20	2 400	0.45	2 150	0.45	4 000	0.45	2 550	0.45

Il est recommandé de réduire l'avance comme suit :

Avance 100 % : A204 (3XD)

Avance 85 % : A205 (5XD)

Avance 70 % : A206 (8XD)

N = R.P.M.

S = Avance par tour (mm/rev.)



corai
Outils coupants

FORETS













FRAISES

TARAUDS



corai

FORETS HSS

			LISTE DES MATIÈRES							
				aciers jusqu'à 30HRc	aciers jusqu'à 45HRc	aciers INOX	fontes	ALU	Titane	plastiques
A421	Forets HSS Co8 DIN 1897 extra courts		p. 18	●		●	●	●	●	
A425	Forets HSS DIN 338 courts		p. 19	●		●	●	●	●	
A402	Forets HSS DIN 338 revêtus TiN		p. 21	●		●	●	●	●	●
A403	Forets HSSCo5 DIN 338 revêtus TiN		p. 23	●		●	●	●	●	●
A423	Forets HSS Co8 DIN 338 courts		p. 25	●		●	●	●	●	
A427	Forets HSS Co8 DIN 340 longs		p. 27	●		●	●	●	●	
A428	Forets HSS DIN 1869/1 longs traitement vapeur		p. 28	●		●	●	●	●	
A453	Forets HSS DIN 345 cône morse traitement vapeur		p. 29	●	○	●	●	●		
A452	Forets HSS-E DIN 345 cône morse		p. 30	●	●	●	●	●		
A455	Forets HSS DIN 1870/1 cône morse longs traitement vapeur		p. 31	●	○	●	●	●		
A456	Forets HSS DIN 1870/2 cône morse longs traitement vapeur		p. 32	●	○	●	●	●		
A461 A463	Forets HSS Co8 NC 90° Forets HSS Co8 NC 120°		p. 33	●		●	●	●		
A480	Forets à centrer HSS forme A 60°		p. 34	●		●	●	●	●	

● utilisation conseillée pour la matière concernée
○ utilisation acceptable

DONNÉES TECHNIQUES

Conditions de coupe recommandées

pages 35 et 36



jusqu'à
1,5 mm



plus de
1,5 mm



réf. A421

conditions de coupe recommandées p. 35

Ø perçage	Dimensions	Réf.	Prix unitaire TARIF H.T.	Ø perçage	Dimensions	Réf.	Prix unitaire TARIF H.T.
1.0	1x6x26	A421 0100	1.98 €	5.9	5.9x28x66	A421 0590	3.77 €
1.1	1.1x7x28	A421 0110	1.98 €	6.0	6.0x28x66	A421 0600	3.77 €
1.2	1.2x8x30	A421 0120	1.98 €	6.1	6.1x31x70	A421 0610	4.02 €
1.3	1.3x8x30	A421 0130	1.98 €	6.2	6.2x31x70	A421 0620	4.02 €
1.4	1.4x9x32	A421 0140	1.98 €	6.3	6.3x31x70	A421 0630	4.02 €
1.5	1.5x9x32	A421 0150	1.98 €	6.4	6.4x31x70	A421 0640	4.02 €
1.6	1.6x10x34	A421 0160	1.84 €	6.5	6.5x31x70	A421 0650	4.02 €
1.7	1.7x10x34	A421 0170	1.84 €	6.6	6.6x31x70	A421 0660	4.22 €
1.8	1.8x11x36	A421 0180	1.84 €	6.7	6.7x31x70	A421 0670	4.22 €
1.9	1.9x11x36	A421 0190	1.84 €	6.8	6.8x34x74	A421 0680	4.22 €
2.0	2.0x12x38	A421 0200	1.39 €	6.9	6.9x34x74	A421 0690	4.22 €
2.1	2.1x12x38	A421 0210	1.78 €	7.0	7.0x34x74	A421 0700	4.22 €
2.2	2.2x13x40	A421 0220	1.78 €	7.1	7.1x34x74	A421 0710	5.23 €
2.3	2.3x13x40	A421 0230	1.78 €	7.2	7.2x34x74	A421 0720	5.23 €
2.4	2.4x14x43	A421 0240	1.78 €	7.3	7.3x34x74	A421 0730	5.23 €
2.5	2.5x14x43	A421 0250	1.78 €	7.4	7.4x34x74	A421 0740	5.23 €
2.6	2.6x14x43	A421 0260	1.98 €	7.5	7.5x34x74	A421 0750	5.23 €
2.7	2.7x16x46	A421 0270	1.98 €	7.6	7.6x37x79	A421 0760	5.49 €
2.8	2.8x16x46	A421 0280	1.98 €	7.7	7.7x37x79	A421 0770	5.49 €
2.9	2.9x16x46	A421 0290	1.98 €	7.8	7.8x37x79	A421 0780	5.49 €
3.0	3.0x16x46	A421 0300	1.98 €	7.9	7.9x37x79	A421 0790	5.49 €
3.1	3.1x18x49	A421 0310	2.16 €	8.0	8.0x37x79	A421 0800	5.49 €
3.2	3.2x18x49	A421 0320	2.16 €	8.1	8.1x37x79	A421 0810	6.18 €
3.3	3.3x18x49	A421 0330	2.16 €	8.2	8.2x37x79	A421 0820	6.18 €
3.4	3.4x20x52	A421 0340	2.16 €	8.3	8.3x37x79	A421 0830	6.18 €
3.5	3.5x20x52	A421 0350	2.16 €	8.4	8.4x37x79	A421 0840	6.18 €
3.6	3.6x20x52	A421 0360	2.36 €	8.5	8.5x37x79	A421 0850	6.18 €
3.7	3.7x20x52	A421 0370	2.36 €	8.6	8.6x40x84	A421 0860	7.00 €
3.8	3.8x22x55	A421 0380	2.36 €	8.7	8.7x40x84	A421 0870	7.00 €
3.9	3.9x22x55	A421 0390	2.36 €	8.8	8.8x40x84	A421 0880	7.00 €
4.0	4.0x22x55	A421 0400	2.36 €	8.9	8.9x40x84	A421 0890	7.00 €
4.1	4.1x22x55	A421 0410	2.80 €	9.0	9.0x40x84	A421 0900	7.00 €
4.2	4.2x22x55	A421 0420	2.80 €	9.1	9.1x40x84	A421 0910	9.62 €
4.3	4.3x24x58	A421 0430	2.80 €	9.2	9.2x40x84	A421 0920	9.62 €
4.4	4.4x24x58	A421 0440	2.80 €	9.3	9.3x40x84	A421 0930	9.62 €
4.5	4.5x24x58	A421 0450	2.80 €	9.4	9.4x40x84	A421 0940	9.62 €
4.6	4.6x24x58	A421 0460	2.88 €	9.5	9.5x40x84	A421 0950	9.62 €
4.7	4.7x24x58	A421 0470	2.88 €	9.6	9.6x43x89	A421 0960	8.79 €
4.8	4.8x26x62	A421 0480	2.88 €	9.7	9.7x43x89	A421 0970	8.79 €
4.9	4.9x26x62	A421 0490	2.88 €	9.8	9.8x43x89	A421 0980	8.79 €
5.0	5.0x26x62	A421 0500	2.88 €	9.9	9.9x43x89	A421 0990	8.79 €
5.1	5.1x26x62	A421 0510	3.37 €	10.0	10x43x89	A421 1000	8.79 €
5.2	5.2x26x62	A421 0520	3.37 €	10.5	10.5x43x89	A421 1050	12.28 €
5.3	5.3x26x62	A421 0530	3.37 €	11.0	11x47x95	A421 1100	13.56 €
5.4	5.4x28x66	A421 0540	3.37 €	11.5	11.5x47x95	A421 1150	15.04 €
5.5	5.5x28x66	A421 0550	3.37 €	12.0	12x51x102	A421 1200	15.67 €
5.6	5.6x28x66	A421 0560	3.77 €	12.5	12.5x51x102	A421 1250	18.66 €
5.7	5.7x28x66	A421 0570	3.77 €	13.0	13x51x102	A421 1300	23.63 €
5.8	5.8x28x66	A421 0580	3.77 €				

► Conditionnement par 10 pièces jusqu'au diamètre 6.5, par 5 pièces au-delà.



réf. A425

conditions de coupe recommandées p. 35

Ø perçage	Dimensions	Réf.	Prix unitaire TARIF H.T.	Ø perçage	Dimensions	Réf.	Prix unitaire TARIF H.T.
0.3	0.3x3x19	A425 0030	1.98 €	5.1	5.1x52x86	A425 0510 V	1.60 €
0.4	0.4x5x20	A425 0040	1.39 €	5.2	5.2x52x86	A425 0520 V	1.60 €
0.5	0.5x6x22	A425 0050	1.22 €	5.3	5.3x52x86	A425 0530 V	1.60 €
0.6	0.6x7x24	A425 0060	1.22 €	5.4	5.4x57x93	A425 0540 V	1.60 €
0.7	0.7x9x28	A425 0070	1.22 €	5.5	5.5x57x93	A425 0550 V	1.98 €
0.8	0.8x10x30	A425 0080	1.14 €	5.6	5.6x57x93	A425 0560 V	2.16 €
0.9	0.9x11x32	A425 0090	0.97 €	5.7	5.7x57x93	A425 0570 V	2.16 €
1.0	1x12x34	A425 0100	0.94 €	5.8	5.8x57x93	A425 0580 V	2.16 €
1.1	1.1x14x36	A425 0110	0.77 €	5.9	5.9x57x93	A425 0590 V	2.16 €
1.2	1.2x16x38	A425 0120	0.77 €	6.0	6.0x57x93	A425 0600 V	1.98 €
1.3	1.3x16x38	A425 0130	0.77 €	6.1	6.1x63x101	A425 0610 V	2.16 €
1.4	1.4x18x40	A425 0140	0.77 €	6.2	6.2x63x101	A425 0620 V	2.16 €
1.5	1.5x18x40	A425 0150	0.77 €	6.3	6.3x63x101	A425 0630 V	2.16 €
1.6	1.6x20x43	A425 0160	0.77 €	6.4	6.4x63x101	A425 0640 V	2.16 €
1.7	1.7x20x43	A425 0170	0.77 €	6.5	6.5x63x101	A425 0650 V	2.43 €
1.8	1.8x22x46	A425 0180	0.77 €	6.6	6.6x63x101	A425 0660 V	2.48 €
1.9	1.9x22x46	A425 0190	0.77 €	6.7	6.7x63x101	A425 0670 V	2.48 €
2.0	2.0x24x49	A425 0200 V	0.77 €	6.8	6.8x69x109	A425 0680 V	2.48 €
2.1	2.1x24x49	A425 0210 V	0.77 €	6.9	6.9x69x109	A425 0690 V	2.48 €
2.2	2.2x27x53	A425 0220 V	0.77 €	7.0	7.0x69x109	A425 0700 V	2.93 €
2.3	2.3x27x53	A425 0230 V	0.77 €	7.1	7.1x69x109	A425 0710 V	3.13 €
2.4	2.4x30x57	A425 0240 V	0.77 €	7.2	7.2x69x109	A425 0720 V	3.13 €
2.5	2.5x30x57	A425 0250 V	0.77 €	7.3	7.3x69x109	A425 0730 V	3.13 €
2.6	2.6x30x57	A425 0260 V	0.82 €	7.4	7.4x69x109	A425 0740 V	3.18 €
2.7	2.7x33x61	A425 0270 V	0.82 €	7.5	7.5x69x109	A425 0750 V	3.13 €
2.8	2.8x33x61	A425 0280 V	0.82 €	7.6	7.6x75x117	A425 0760 V	3.32 €
2.9	2.9x33x61	A425 0290 V	0.82 €	7.7	7.7x75x117	A425 0770 V	3.43 €
3.0	3.0x33x61	A425 0300 V	0.94 €	7.8	7.8x75x117	A425 0780 V	3.43 €
3.1	3.1x36x65	A425 0310 V	0.94 €	7.9	7.9x75x117	A425 0790 V	3.43 €
3.2	3.2x36x65	A425 0320 V	0.94 €	8.0	8.0x75x117	A425 0800 V	3.13 €
3.3	3.3x36x65	A425 0330 V	0.94 €	8.1	8.1x75x117	A425 0810 V	4.39 €
3.4	3.4x39x70	A425 0340 V	0.94 €	8.2	8.2x75x117	A425 0820 V	4.39 €
3.5	3.5x39x70	A425 0350 V	1.01 €	8.3	8.3x75x117	A425 0830 V	4.64 €
3.6	3.6x39x70	A425 0360 V	1.27 €	8.4	8.4x75x117	A425 0840 V	4.64 €
3.7	3.7x39x70	A425 0370 V	1.27 €	8.5	8.5x75x117	A425 0850 V	4.07 €
3.8	3.8x43x75	A425 0380 V	1.27 €	8.6	8.6x81x125	A425 0860 V	5.17 €
3.9	3.9x43x75	A425 0390 V	1.27 €	8.7	8.7x81x125	A425 0870 V	5.17 €
4.0	4.0x43.0x75	A425 0400 V	1.10 €	8.8	8.8x81x125	A425 0880 V	5.17 €
4.1	4.1x43x75	A425 0410 V	1.27 €	8.9	8.9x81x125	A425 0890 V	5.17 €
4.2	4.2x43x75	A425 0420 V	1.27 €	9.0	9.0x81x125	A425 0900 V	4.52 €
4.3	4.3x47x80	A425 0430 V	1.34 €	9.1	9.1x81x125	A425 0910 V	5.61 €
4.4	4.4x47x80	A425 0440 V	1.34 €	9.2	9.2x81x125	A425 0920 V	5.61 €
4.5	4.5x47.0x80	A425 0450 V	1.39 €	9.3	9.3x81x125	A425 0930 V	5.99 €
4.6	4.6x47x80	A425 0460 V	1.53 €	9.4	9.4x81x125	A425 0940 V	5.99 €
4.7	4.7x47x80	A425 0470 V	1.53 €	9.5	9.5x81x125	A425 0950 V	5.23 €
4.8	4.8x52x86	A425 0480 V	1.53 €	9.6	9.6x87x133	A425 0960 V	6.18 €
4.9	4.9x52x86	A425 0490 V	1.53 €	9.7	9.7x87x133	A425 0970 V	6.18 €
5.0	5.0x52x86	A425 0500 V	1.34 €	9.8	9.8x87x133	A425 0980 V	6.31 €

voir suite ...

- Conditionnement par 10 pièces jusqu'au diamètre 6.5, par 5 pièces jusqu'au diamètre 13, à l'unité au-delà.
- Traitement vapeur à partir du diamètre 2.



réf. A425 suite

conditions de coupe recommandées p. 35

Ø perçage	Dimensions	Réf.	Prix unitaire TARIF H.T.
9.9	9.9x87x133	A425 0990 V	6.31 €
10.0	10x87x133	A425 1000 V	5.43 €
10.1	10.1x87x133	A425 1010 V	6.44 €
10.2	10.2x87x133	A425 1020 V	6.69 €
10.3	10.3x87x133	A425 1030 V	6.76 €
10.4	10.4x87x133	A425 1040 V	6.76 €
10.5	10.5x87x133	A425 1050 V	6.76 €
10.6	10.6x87x133	A425 1060 V	6.89 €
10.7	10.7x94x142	A425 1070 V	6.89 €
10.8	10.8x94x142	A425 1080 V	6.89 €
10.9	10.9x94x142	A425 1090 V	6.89 €
11.0	11.0x94x142	A425 1100 V	6.89 €
11.1	11.1x94x142	A425 1110 V	8.54 €
11.2	11.2x94x142	A425 1120 V	8.54 €
11.3	11.3x94x142	A425 1130 V	8.54 €
11.4	11.4x94x142	A425 1140 V	8.54 €
11.5	11.5x94x142	A425 1150 V	8.54 €
11.6	11.6x94x142	A425 1160 V	8.54 €
11.7	11.7x94x142	A425 1170 V	8.54 €
11.8	11.8x94x142	A425 1180 V	8.54 €
11.9	11.9x101x151	A425 1190 V	8.54 €
12.0	12.0x101x151	A425 1200 V	8.54 €
12.1	12.1x101x151	A425 1210 V	8.85 €
12.2	12.2x101x151	A425 1220 V	8.85 €
12.3	12.3x101x151	A425 1230 V	8.85 €
12.4	12.4x101x151	A425 1240 V	10.07 €
12.5	12.5x101x151	A425 1250 V	10.07 €
12.6	12.6x101x151	A425 1260 V	10.07 €
12.7	12.7x101x151	A425 1270 V	10.07 €
12.8	12.8x101x151	A425 1280 V	10.07 €
12.9	12.9x101x151	A425 1290 V	10.07 €
13.0	13.0x101x151	A425 1300 V	10.07 €
13.5	13.5x108x160	A425 1350 V	12.36 €
14.0	14x108x160	A425 1400 V	12.36 €
14.5	14.5x114x169	A425 1450 V	14.84 €
15.0	15x114x169	A425 1500 V	14.84 €
15.5	15.5x120x178	A425 1550 V	17.83 €
16.0	16x120x178	A425 1600 V	17.83 €
16.5	16.5x125x184	A425 1650 V	20.64 €
17.0	17x125x184	A425 1700 V	20.64 €
17.5	17.5x130x191	A425 1750 V	25.37 €
18.0	18x130x191	A425 1800 V	25.37 €
18.5	18.5x135x198	A425 1850 V	28.91 €
19.0	19x135x198	A425 1900 V	28.03 €
19.5	19.5x140x205	A425 1950 V	32.04 €
20.0	20x140x205	A425 2000 V	35.55 €



réf. A402

conditions de coupe recommandées p. 35

Ø perçage	Dimensions	Réf.	Prix unitaire TARIF H.T.	Ø perçage	Dimensions	Réf.	Prix unitaire TARIF H.T.
1.6	1.6X20X43	A402 0160 N	1.10 €	5.5	5.5X57X93	A402 0550 N	2.67 €
1.7	1.7X20X43	A402 0170 N	1.10 €	5.6	5.6X57X93	A402 0560 N	2.67 €
1.8	1.8X22X46	A402 0180 N	1.10 €	5.7	5.7X57X93	A402 0570 N	2.67 €
1.9	1.9X22X46	A402 0190 N	1.10 €	5.8	5.8X57X93	A402 0580 N	2.67 €
2.0	2X24X49	A402 0200 N	1.10 €	5.9	5.9X57X93	A402 0590 N	2.67 €
2.1	2.1X24X49	A402 0210 N	1.22 €	6.0	6X57X93	A402 0600 N	2.73 €
2.2	2.2X27X53	A402 0220 N	1.22 €	6.1	6.1X63X101	A402 0610 N	2.93 €
2.3	2.3X27X53	A402 0230 N	1.22 €	6.2	6.2X63X101	A402 0620 N	2.93 €
2.4	2.4X30X57	A402 0240 N	1.22 €	6.3	6.3X63X101	A402 0630 N	2.93 €
2.5	2.5X30X57	A402 0250 N	1.22 €	6.4	6.4X63X101	A402 0640 N	2.93 €
2.6	2.6X30X57	A402 0260 N	1.15 €	6.5	6.5X63X101	A402 0650 N	3.06 €
2.7	2.7X33X61	A402 0270 N	1.15 €	6.6	6.6X63X101	A402 0660 N	3.58 €
2.8	2.8X33X61	A402 0280 N	1.15 €	6.7	6.7X63X101	A402 0670 N	3.58 €
2.9	2.9X33X61	A402 0290 N	1.15 €	6.8	6.8X69X109	A402 0680 N	3.58 €
3.0	3X33X61	A402 0300 N	1.22 €	6.9	6.9X69X109	A402 0690 N	3.58 €
3.1	3.1X36X65	A402 0310 N	1.27 €	7.0	7X69X109	A402 0700 N	3.94 €
3.2	3.2X36X65	A402 0320 N	1.27 €	7.1	7.1X69X109	A402 0710 N	4.02 €
3.3	3.3X36X65	A402 0330 N	1.27 €	7.2	7.2X69X109	A402 0720 N	4.02 €
3.4	3.4X39X70	A402 0340 N	1.27 €	7.3	7.3X69X109	A402 0730 N	4.02 €
3.5	3.5X39X70	A402 0350 N	1.60 €	7.4	7.4X69X109	A402 0740 N	4.02 €
3.6	3.6X39X70	A402 0360 N	1.60 €	7.5	7.5X69X109	A402 0750 N	4.47 €
3.7	3.7X39X70	A402 0370 N	1.60 €	7.6	7.6X75X117	A402 0760 N	4.47 €
3.8	3.8X43X75	A402 0380 N	1.60 €	7.7	7.7X75X117	A402 0770 N	4.47 €
3.9	3.9X43X75	A402 0390 N	1.60 €	7.8	7.8X75X117	A402 0780 N	4.47 €
4.0	4X43X75	A402 0400 N	1.67 €	7.9	7.9X75X117	A402 0790 N	4.47 €
4.1	4.1X43X75	A402 0410 N	1.78 €	8.0	8X75X117	A402 0800 N	5.09 €
4.2	4.2X43X75	A402 0420 N	1.78 €	8.1	8.1X75X117	A402 0810 N	5.61 €
4.3	4.3X47X80	A402 0430 N	1.78 €	8.2	8.2X75X117	A402 0820 N	5.61 €
4.4	4.4X47X80	A402 0440 N	1.78 €	8.3	8.3X75X117	A402 0830 N	5.61 €
4.5	4.5X47X80	A402 0450 N	1.84 €	8.4	8.4X75X117	A402 0840 N	5.61 €
4.6	4.6X47X80	A402 0460 N	1.84 €	8.5	8.5X75X117	A402 0850 N	6.06 €
4.7	4.7X47X80	A402 0470 N	1.84 €	8.6	8.6X81X125	A402 0860 N	6.06 €
4.8	4.8X52X86	A402 0480 N	1.84 €	8.7	8.7X81X125	A402 0870 N	6.06 €
4.9	4.9X52X86	A402 0490 N	1.84 €	8.8	8.8X81X125	A402 0880 N	6.06 €
5.0	5X52X86	A402 0500 N	2.04 €	8.9	8.9X81X125	A402 0890 N	6.06 €
5.1	5.1X52X86	A402 0510 N	2.48 €	9.0	9X81X125	A402 0900 N	6.83 €
5.2	5.2X52X86	A402 0520 N	2.48 €	9.1	9.1X81X125	A402 0910 N	7.00 €
5.3	5.3X52X86	A402 0530 N	2.48 €	9.2	9.2X81X125	A402 0920 N	7.00 €
5.4	5.4X57X93	A402 0540 N	2.48 €	9.3	9.3X81X125	A402 0930 N	7.19 €

voir suite ...

► Conditionnement par 10 pièces jusqu'au diamètre 6.5, par 5 pièces au-delà.



réf. A402 suite

conditions de coupe recommandées p. 35

Ø perçage	Dimensions	Réf.	Prix unitaire TARIF H.T.
9.4	9.4X81X125	A402 0940 N	7.19 €
9.5	9.5X81X125	A402 0950 N	7.40 €
9.6	9.6X87X133	A402 0960 N	7.65 €
9.7	9.7X87X133	A402 0970 N	7.65 €
9.8	9.8X87X133	A402 0980 N	7.77 €
9.9	9.9X87X133	A402 0990 N	7.77 €
10.0	10X87X133	A402 1000 N	7.84 €
10.1	10.1X87X133	A402 1010 N	8.54 €
10.2	10.2X87X133	A402 1020 N	8.54 €
10.3	10.3X87X133	A402 1030 N	8.54 €
10.4	10.4X87X133	A402 1040 N	8.54 €
10.5	10.5X87X133	A402 1050 N	8.54 €
10.6	10.6X87X133	A402 1060 N	9.88 €
10.7	10.7X94X142	A402 1070 N	9.88 €
10.8	10.8X94X142	A402 1080 N	9.88 €
10.9	10.9X94X142	A402 1090 N	9.88 €
11.0	11X94X142	A402 1100 N	10.37 €
11.1	11.1X94X142	A402 1110 N	10.58 €
11.2	11.2X94X142	A402 1120 N	10.58 €
11.3	11.3X94X142	A402 1130 N	10.58 €
11.4	11.4X94X142	A402 1140 N	10.58 €
11.5	11.5X94X142	A402 1150 N	10.58 €
11.6	11.6X94X142	A402 1160 N	12.10 €
11.7	11.7X94X142	A402 1170 N	12.10 €
11.8	11.8X94X142	A402 1180 N	12.10 €
11.9	11.9X101X151	A402 1190 N	12.10 €
12.0	12X101X151	A402 1200 N	12.28 €
12.1	12.1X101X151	A402 1210 N	12.88 €
12.2	12.2X101X151	A402 1220 N	12.88 €
12.3	12.3X101X151	A402 1230 N	12.88 €
12.4	12.4X101X151	A402 1240 N	12.88 €
12.5	12.5X101X151	A402 1250 N	12.88 €
12.6	12.6X101X151	A402 1260 N	14.52 €
12.7	12.7X101X151	A402 1270 N	14.52 €
12.8	12.8X101X151	A402 1280 N	14.52 €
12.9	12.9X101X151	A402 1290 N	14.52 €
13.0	13X101X151	A402 1300 N	14.90 €

► Conditionnement par 10 pièces jusqu'au diamètre 6.5, par 5 pièces au-delà.



jusqu'à
1,5 mm



plus de
1,5 mm



réf. A403

conditions de coupe recommandées p. 35

Ø perçage	Dimensions	Réf.	Prix unitaire TARIF H.T.	Ø perçage	Dimensions	Réf.	Prix unitaire TARIF H.T.
1.0	1x12x34	A403 0100 N	1.67 €	5.1	5.1x52x86	A403 0510 N	4.07 €
1.1	1.1x14x36	A403 0110 N	1.67 €	5.2	5.2x52x86	A403 0520 N	4.07 €
1.2	1.2x16x38	A403 0120 N	1.67 €	5.3	5.3x52x86	A403 0530 N	4.07 €
1.3	1.3x16x38	A403 0130 N	1.67 €	5.4	5.4x57x93	A403 0540 N	4.07 €
1.4	1.4x18x40	A403 0140 N	1.67 €	5.5	5.5x57x93	A403 0550 N	4.07 €
1.5	1.5x18x40	A403 0150 N	1.67 €	5.6	5.6x57x93	A403 0560 N	4.39 €
1.6	1.6x20x43	A403 0160 N	1.78 €	5.7	5.7x57x93	A403 0570 N	4.39 €
1.7	1.7x20x43	A403 0170 N	1.78 €	5.8	5.8x57x93	A403 0580 N	4.39 €
1.8	1.8x22x46	A403 0180 N	1.78 €	5.9	5.9x57x93	A403 0590 N	4.39 €
1.9	1.9x22x46	A403 0190 N	1.78 €	6.0	6x57x93	A403 0600 N	4.39 €
2.0	2x24x49	A403 0200 N	1.78 €	6.1	6.1x63x101	A403 0610 N	4.97 €
2.1	2.1x24x49	A403 0210 N	1.84 €	6.2	6.2x63x101	A403 0620 N	4.97 €
2.2	2.2x27x53	A403 0220 N	1.84 €	6.3	6.3x63x101	A403 0630 N	4.97 €
2.3	2.3x27x53	A403 0230 N	1.84 €	6.4	6.4x63x101	A403 0640 N	4.97 €
2.4	2.4x30x57	A403 0240 N	1.84 €	6.5	6.5x63x101	A403 0650 N	4.97 €
2.5	2.5x30x57	A403 0250 N	1.84 €	6.6	6.6x63x101	A403 0660 N	5.43 €
2.6	2.6x30x57	A403 0260 N	2.04 €	6.7	6.7x63x101	A403 0670 N	5.43 €
2.7	2.7x33x61	A403 0270 N	2.04 €	6.8	6.8x69x109	A403 0680 N	5.43 €
2.8	2.8x33x61	A403 0280 N	2.04 €	6.9	6.9x69x109	A403 0690 N	5.43 €
2.9	2.9x33x61	A403 0290 N	2.04 €	7.0	7x69x109	A403 0700 N	5.43 €
3.0	3x33x61	A403 0300 N	2.04 €	7.1	7.1x69x109	A403 0710 N	6.50 €
3.1	3.1x36x65	A403 0310 N	2.22 €	7.2	7.2x69x109	A403 0720 N	6.50 €
3.2	3.2x36x65	A403 0320 N	2.22 €	7.3	7.3x69x109	A403 0730 N	6.50 €
3.3	3.3x36x65	A403 0330 N	2.22 €	7.4	7.4x69x109	A403 0740 N	6.50 €
3.4	3.4x39x70	A403 0340 N	2.22 €	7.5	7.5x69x109	A403 0750 N	6.50 €
3.5	3.5x39x70	A403 0350 N	2.22 €	7.6	7.6x75x117	A403 0760 N	7.19 €
3.6	3.6x39x70	A403 0360 N	2.80 €	7.7	7.7x75x117	A403 0770 N	7.19 €
3.7	3.7x39x70	A403 0370 N	2.80 €	7.8	7.8x75x117	A403 0780 N	7.19 €
3.8	3.8x43x75	A403 0380 N	2.80 €	7.9	7.9x75x117	A403 0790 N	7.19 €
3.9	3.9x43x75	A403 0390 N	2.80 €	8.0	8x75x117	A403 0800 N	7.19 €
4.0	4x43x75	A403 0400 N	2.80 €	8.1	8.1x75x117	A403 0810 N	7.84 €
4.1	4.1x43x75	A403 0410 N	3.26 €	8.2	8.2x75x117	A403 0820 N	7.84 €
4.2	4.2x43x75	A403 0420 N	3.26 €	8.3	8.3x75x117	A403 0830 N	7.84 €
4.3	4.3x47x80	A403 0430 N	3.26 €	8.4	8.4x75x117	A403 0840 N	7.84 €
4.4	4.4x47x80	A403 0440 N	3.26 €	8.5	8.5x75x117	A403 0850 N	7.84 €
4.5	4.5x47x80	A403 0450 N	3.26 €	8.6	8.6x81x125	A403 0860 N	8.92 €
4.6	4.6x47x80	A403 0460 N	3.26 €	8.7	8.7x81x125	A403 0870 N	8.92 €
4.7	4.7x47x80	A403 0470 N	3.26 €	8.8	8.8x81x125	A403 0880 N	8.92 €
4.8	4.8x52x86	A403 0480 N	3.26 €	8.9	8.9x81x125	A403 0890 N	8.92 €
4.9	4.9x52x86	A403 0490 N	3.26 €	9.0	9x81x125	A403 0900 N	8.92 €
5.0	5x52x86	A403 0500 N	3.26 €	9.1	9.1x81x125	A403 0910 N	11.22 €

voir suite ...

► Conditionnement par 10 pièces jusqu'au diamètre 6.5, par 5 pièces au-delà.



jusqu'à
1,5 mm



plus de
1,5 mm



réf. A403 suite

conditions de coupe recommandées p. 35

Ø perçage	Dimensions	Réf.	Prix unitaire TARIF H.T.
9.2	9.2x81x125	A403 0920 N	11.22 €
9.3	9.3x81x125	A403 0930 N	11.22 €
9.4	9.4x81x125	A403 0940 N	11.22 €
9.5	9.5x81x125	A403 0950 N	11.22 €
9.6	9.6x87x133	A403 0960 N	11.22 €
9.7	9.7x87x133	A403 0970 N	11.22 €
9.8	9.8x87x133	A403 0980 N	11.22 €
9.9	9.9x87x133	A403 0990 N	11.22 €
10.0	10x87x133	A403 1000 N	11.22 €
10.1	10.1x87x133	A403 1010 N	12.88 €
10.2	10.2x87x133	A403 1020 N	12.88 €
10.3	10.3x87x133	A403 1030 N	12.88 €
10.4	10.4x87x133	A403 1040 N	12.88 €
10.5	10.5x87x133	A403 1050 N	12.88 €
10.6	10.6x87x133	A403 1060 N	13.31 €
10.7	10.7x94x142	A403 1070 N	13.31 €
10.8	10.8x94x142	A403 1080 N	13.31 €
10.9	10.9x94x142	A403 1090 N	13.31 €
11.0	11x94x142	A403 1100 N	13.31 €
11.1	11.1x94x142	A403 1110 N	15.99 €
11.2	11.2x94x142	A403 1120 N	15.99 €
11.3	11.3x94x142	A403 1130 N	15.99 €
11.4	11.4x94x142	A403 1140 N	15.99 €
11.5	11.5x94x142	A403 1150 N	15.99 €
11.6	11.6x94x142	A403 1160 N	15.99 €
11.7	11.7x94x142	A403 1170 N	15.99 €
11.8	11.8x94x142	A403 1180 N	15.99 €
11.9	11.9x101x151	A403 1190 N	15.99 €
12.0	12x101x151	A403 1200 N	15.99 €
12.1	12.1x101x151	A403 1210 N	17.89 €
12.2	12.2x101x151	A403 1220 N	17.89 €
12.3	12.3x101x151	A403 1230 N	17.89 €
12.4	12.4x101x151	A403 1240 N	17.89 €
12.5	12.5x101x151	A403 1250 N	18.33 €
12.6	12.6x101x151	A403 1260 N	18.33 €
12.7	12.7x101x151	A403 1270 N	18.33 €
12.8	12.8x101x151	A403 1280 N	18.33 €
12.9	12.9x101x151	A403 1290 N	18.33 €
13.0	13x101x151	A403 1300 N	18.88 €

► Conditionnement par 10 pièces jusqu'au diamètre 6.5, par 5 pièces au-delà.



jusqu'à
1,5 mm



plus de
1,5 mm



réf. A423

conditions de coupe recommandées p. 35

Ø perçage	Dimensions	Réf.	Prix unitaire TARIF H.T.	Ø perçage	Dimensions	Réf.	Prix unitaire TARIF H.T.
1.0	1.0x12x34	A423 0100	2.31 €	4.8	4.8x52x86	A423 0480	3.37 €
1.1	1.1x14x36	A423 0110	2.31 €	4.9	4.9x52x86	A423 0490	3.37 €
1.2	1.2x16x38	A423 0120	2.31 €	5.0	5.0x52x86	A423 0500	3.37 €
1.3	1.30x16x38	A423 0130	2.31 €	5.1	5.1x52x86	A423 0510	3.94 €
1.4	1.4x18x40	A423 0140	2.31 €	5.2	5.2x52x86	A423 0520	3.94 €
1.5	1.5x18x40	A423 0150	2.31 €	5.3	5.3x52x86	A423 0530	3.94 €
1.6	1.6x20x43	A423 0160	2.31 €	5.4	5.4x57x93	A423 0540	3.94 €
1.7	1.7x20x43	A423 0170	2.31 €	5.5	5.5x57x93	A423 0550	3.94 €
1.8	1.8x22x46	A423 0180	2.31 €	5.6	5.6x57x93	A423 0560	4.39 €
1.9	1.9x22x46	A423 0190	2.31 €	5.7	5.7x57x93	A423 0570	4.39 €
2.0	2.0x24x49	A423 0200	2.31 €	5.8	5.8x57x93	A423 0580	4.39 €
2.1	2.1x24x49	A423 0210	2.31 €	5.9	5.9x57x93	A423 0590	4.39 €
2.2	2.2x27x53	A423 0220	2.22 €	6.0	6.0x57x93	A423 0600	4.39 €
2.3	2.3x27x53	A423 0230	2.22 €	6.1	6.1x63x101	A423 0610	4.79 €
2.4	2.4x30x57	A423 0240	2.22 €	6.2	6.2x63x101	A423 0620	4.79 €
2.5	2.5x30x57	A423 0250	2.22 €	6.3	6.3x63x101	A423 0630	4.79 €
2.6	2.6x30x57	A423 0260	2.31 €	6.4	6.4x63x101	A423 0640	4.79 €
2.7	2.7x33x61	A423 0270	2.31 €	6.5	6.5x63x101	A423 0650	4.79 €
2.8	2.8x33x61	A423 0280	2.31 €	6.6	6.6x63x101	A423 0660	4.97 €
2.9	2.9x33x61	A423 0290	2.31 €	6.7	6.7x63x101	A423 0670	4.97 €
3.0	3.0x33x61	A423 0300	2.22 €	6.8	6.8x69x109	A423 0680	4.97 €
3.1	3.1x36x65	A423 0310	2.43 €	6.9	6.9x69x109	A423 0690	4.97 €
3.2	3.2x36x65	A423 0320	2.43 €	7.0	7.0x69x109	A423 0700	4.97 €
3.3	3.3x36x65	A423 0330	2.43 €	7.1	7.1x69x109	A423 0710	6.06 €
3.4	3.4x39x70	A423 0340	2.43 €	7.2	7.2x69x109	A423 0720	6.06 €
3.5	3.5x39x70	A423 0350	2.31 €	7.3	7.3x69x109	A423 0730	6.06 €
3.6	3.6x39x70	A423 0360	2.88 €	7.4	7.4x69x109	A423 0740	6.06 €
3.7	3.7x39x70	A423 0370	2.88 €	7.5	7.5x69x109	A423 0750	6.06 €
3.8	3.8x43x75	A423 0380	2.88 €	7.6	7.6x75x117	A423 0760	6.50 €
3.9	3.9x43x75	A423 0390	2.88 €	7.7	7.7x75x117	A423 0770	6.50 €
4.0	4.0x43x75	A423 0400	2.88 €	7.8	7.8x75x117	A423 0780	6.50 €
4.1	4.1x43x75	A423 0410	3.18 €	7.9	7.9x75x117	A423 0790	6.50 €
4.2	4.2x43x75	A423 0420	3.06 €	8.0	8.0x75x117	A423 0800	6.50 €
4.3	4.3x47x80	A423 0430	3.18 €	8.1	8.1x75x117	A423 0810	7.19 €
4.4	4.4x47x80	A423 0440	3.18 €	8.2	8.2x75x117	A423 0820	7.19 €
4.5	4.5x47x80	A423 0450	3.18 €	8.3	8.3x75x117	A423 0830	7.19 €
4.6	4.6x47x80	A423 0460	3.37 €	8.4	8.4x75x117	A423 0840	7.19 €
4.7	4.7x47x80	A423 0470	3.37 €	8.5	8.5x75x117	A423 0850	7.19 €

voir suite ...

► Conditionnement par 10 pièces jusqu'au diamètre 6.5, par 5 pièces jusqu'au diamètre 13, à l'unité au-delà.



jusqu'à
1,5 mm



plus de
1,5 mm



réf. A423 *suite*

conditions de coupe recommandées p. 35

Ø perçage	Dimensions	Réf.	Prix unitaire TARIF H.T.
8.6	8.6x81x125	A423 0860	8.28 €
8.7	8.7x81x125	A423 0870	8.28 €
8.8	8.8x81x125	A423 0880	8.28 €
8.9	8.9x81x125	A423 0890	8.28 €
9.0	9.0x81x125	A423 0900	8.28 €
9.1	9.1x81x125	A423 0910	11.27 €
9.2	9.2x81x125	A423 0920	11.27 €
9.3	9.3x81x125	A423 0930	11.27 €
9.4	9.4x81x125	A423 0940	11.27 €
9.5	9.5x81x125	A423 0950	11.27 €
9.6	9.6x87x133	A423 0960	10.32 €
9.7	9.7x87x133	A423 0970	10.32 €
9.8	9.8x87x133	A423 0980	10.32 €
9.9	9.9x87x133	A423 0990	10.32 €
10.0	10.0x87x133	A423 1000	10.32 €
10.2	10.2x87x133	A423 1020	14.27 €
10.5	10.5x87x133	A423 1050	14.27 €
11.0	11.0x94x142	A423 1100	15.93 €
11.5	11.5x94x142	A423 1150	17.77 €
12.0	12.0x101x151	A423 1200	18.33 €
12.5	12.5x101x151	A423 1250	21.91 €
13.0	13.0x101x151	A423 1300	27.78 €
13.5	13.5x108x160	A423 1350	28.79 €
14.0	14x108x160	A423 1400	29.94 €
14.5	14.5x114x169	A423 1450	30.26 €
15.0	15x114x169	A423 1500	30.51 €
15.5	15.5x120x178	A423 1550	34.59 €
16.0	16x120x178	A423 1600	35.55 €
16.5	16.5x125x184	A423 1650	39.24 €
17.0	17x125x184	A423 1700	39.24 €
17.5	17.5x130x191	A423 1750	44.21 €
18.0	18x130x191	A423 1800	44.21 €
18.5	18.5x135x198	A423 1850	51.53 €
19.0	19x135x198	A423 1900	51.53 €
19.5	19.5x140x205	A423 1950	55.94 €
20.0	20x140x205	A423 2000	60.83 €

► Conditionnement par 10 pièces jusqu'au diamètre 6.5, par 5 pièces jusqu'au diamètre 13, à l'unité au-delà.



réf. A427

conditions de coupe recommandées p. 35

Ø perçage	Dimensions	Réf.	Prix unitaire TARIF H.T.	Ø perçage	Dimensions	Réf.	Prix unitaire TARIF H.T.
2.0	2x56x85	A427 0200	3.13 €	6.5	6.5x97x148	A427 0650	6.76 €
2.1	2.1x56x85	A427 0210	3.13 €	6.6	6.6x97x148	A427 0660	7.00 €
2.2	2.2x59x90	A427 0220	2.99 €	6.7	6.7x97x148	A427 0670	7.00 €
2.3	2.3x59x90	A427 0230	2.99 €	6.8	6.8x102x156	A427 0680	7.00 €
2.4	2.4x62x95	A427 0240	2.99 €	6.9	6.9x102x156	A427 0690	7.00 €
2.5	2.5x62x95	A427 0250	2.99 €	7.0	7x102x156	A427 0700	7.00 €
2.6	2.6x62x95	A427 0260	3.18 €	7.1	7.1x102x156	A427 0710	8.40 €
2.7	2.7x66x100	A427 0270	3.18 €	7.2	7.2x102x156	A427 0720	8.40 €
2.8	2.8x66x100	A427 0280	3.18 €	7.3	7.3x102x156	A427 0730	8.40 €
2.9	2.9x66x100	A427 0290	3.18 €	7.4	7.4x102x156	A427 0740	8.40 €
3.0	3.0x66x100	A427 0300	3.18 €	7.5	7.5x102x156	A427 0750	8.40 €
3.1	3.1x69x106	A427 0310	3.43 €	7.6	7.6x109x165	A427 0760	9.11 €
3.2	3.2x69x106	A427 0320	3.43 €	7.7	7.7x109x165	A427 0770	9.11 €
3.3	3.3x69x106	A427 0330	3.43 €	7.8	7.8x109x165	A427 0780	9.11 €
3.4	3.4x73x112	A427 0340	3.43 €	7.9	7.9x109x165	A427 0790	9.11 €
3.5	3.5x73x112	A427 0350	3.43 €	8.0	8x109x165	A427 0800	9.11 €
3.6	3.6x73x112	A427 0360	3.94 €	8.1	8.1x109x165	A427 0810	10.13 €
3.7	3.7x73x112	A427 0370	3.94 €	8.2	8.2x109x165	A427 0820	10.13 €
3.8	3.8x78x119	A427 0380	3.94 €	8.3	8.3x109x165	A427 0830	10.13 €
3.9	3.9x78x119	A427 0390	3.94 €	8.4	8.4x109x165	A427 0840	10.13 €
4.0	4.0x78x119	A427 0400	3.94 €	8.5	8.5x109x165	A427 0850	10.13 €
4.1	4.1x78x119	A427 0410	4.52 €	8.6	8.6x115x175	A427 0860	11.54 €
4.2	4.2x78x119	A427 0420	4.52 €	8.7	8.7x115x175	A427 0870	11.54 €
4.3	4.3x82x126	A427 0430	4.52 €	8.8	8.8x115x175	A427 0880	11.54 €
4.4	4.4x82x126	A427 0440	4.52 €	8.9	8.9x115x175	A427 0890	11.54 €
4.5	4.5x82x126	A427 0450	4.52 €	9.0	9x115x175	A427 0900	11.54 €
4.6	4.6x82x126	A427 0460	4.71 €	9.1	9.1x115x175	A427 0910	15.80 €
4.7	4.7x82x126	A427 0470	4.71 €	9.2	9.2x115x175	A427 0920	15.80 €
4.8	4.8x87x132	A427 0480	4.71 €	9.3	9.3x115x175	A427 0930	15.80 €
4.9	4.9x87x132	A427 0490	4.71 €	9.4	9.4x115x175	A427 0940	15.80 €
5.0	5x87x132	A427 0500	4.71 €	9.5	9.5x115x175	A427 0950	15.80 €
5.1	5.1x87x132	A427 0510	5.49 €	9.6	9.6x121x184	A427 0960	14.40 €
5.2	5.2x87x132	A427 0520	5.49 €	9.7	9.7x121x184	A427 0970	14.40 €
5.3	5.3x87x139	A427 0530	5.49 €	9.8	9.8x121x184	A427 0980	14.40 €
5.4	5.4x91x139	A427 0540	5.49 €	9.9	9.9x121x184	A427 0990	14.40 €
5.5	5.5x91x139	A427 0550	5.49 €	10.0	10x121x184	A427 1000	14.40 €
5.6	5.6x91x139	A427 0560	6.11 €	10.2	10.2x121x184	A427 1020	20.13 €
5.7	5.7x91x139	A427 0570	6.11 €	10.5	10.5x121x184	A427 1050	20.13 €
5.8	5.8x91x139	A427 0580	6.11 €	10.8	10.8x128x195	A427 1080	20.13 €
5.9	5.9x91x139	A427 0590	6.11 €	11.0	11x128x195	A427 1100	22.41 €
6.0	6x91x139	A427 0600	6.11 €	11.2	11.2x128x195	A427 1120	22.41 €
6.1	6.1x97x148	A427 0610	6.76 €	11.5	11.5x128x195	A427 1150	24.83 €
6.2	6.2x97x148	A427 0620	6.76 €	11.8	11.8x128x195	A427 1180	25.72 €
6.3	6.3x97x148	A427 0630	6.76 €	12.0	12x134x205	A427 1200	25.72 €
6.4	6.4x97x148	A427 0640	6.76 €				

► Conditionnement par 10 pièces jusqu'au diamètre 6.5, par 5 pièces au-delà.



réf. A428

conditions de coupe recommandées p. 35

Ø perçage	Dimensions	Réf.	Prix unitaire TARIF H.T.
2.0	2x85x125	A428 0200 V	4.52 €
2.25	2.25x90x135	A428 0225 V	4.52 €
2.5	2.5x95x140	A428 0250 V	4.52 €
2.75	2.75x100x150	A428 0275 V	4.79 €
3.0	3x100x150	A428 0300 V	4.79 €
3.25	3.25x105x155	A428 0325 V	5.23 €
3.5	3.5x115x165	A428 0350 V	5.23 €
3.75	3.75x115x165	A428 0375 V	5.28 €
4.0	4x120x175	A428 0400 V	5.28 €
4.25	4.25x120x175	A428 0425 V	5.79 €
4.5	4.5x125x185	A428 0450 V	5.79 €
4.75	4.75x125x185	A428 0475 V	6.11 €
5.0	5x135x195	A428 0500 V	6.11 €
5.25	5.25x135x195	A428 0525 V	8.28 €
5.5	5.5x140x205	A428 0550 V	8.28 €
5.75	5.75x140x205	A428 0575 V	8.79 €
6.0	6x140x205	A428 0600 V	8.79 €
6.25	6.25x150x215	A428 0625 V	11.09 €
6.5	6.5x150x215	A428 0650 V	11.09 €
6.75	6.75x155x225	A428 0675 V	12.23 €
7.0	7x155x225	A428 0700 V	12.23 €
7.25	7.25x155x225	A428 0725 V	14.90 €
7.5	7.5x155x225	A428 0750 V	14.90 €
7.75	7.75x165x240	A428 0775 V	15.67 €
8.0	8x165x240	A428 0800 V	15.67 €
8.25	8.25x165x240	A428 0825 V	16.26 €
8.5	8.5x165x240	A428 0850 V	16.26 €
8.75	8.75x175x250	A428 0875 V	16.51 €
9.0	9.0x175x250	A428 0900 V	16.51 €
9.25	9.25x175x250	A428 0925 V	17.07 €
9.5	9.5x175x250	A428 0950 V	17.07 €
9.75	9.75x185x265	A428 0975 V	17.38 €
10.0	10x185x265	A428 1000 V	17.38 €
10.5	10.5x185x265	A428 1050 V	24.98 €
11.0	11x195x280	A428 1100 V	31.27 €
11.5	11.5x195x280	A428 1150 V	33.45 €
12.0	12x205x295	A428 1200 V	41.28 €
12.5	12.5x205x295	A428 1250 V	47.58 €
13.0	13x205x295	A428 1300 V	49.50 €

► Conditionnement par 5 pièces jusqu'au diamètre 8, à l'unité au-delà.

FORETS HSS DIN 345 CÔNE MORSE TRAITEMENT VAPEUR



réf. A453

conditions de coupe recommandées p. 36

Ø perçage	Dimensions	Réf.	Prix unitaire TARIF H.T.	Ø perçage	Dimensions	Réf.	Prix unitaire TARIF H.T.
13.0	13x101x182	A453 1300 VT	27.97 €	34.0	34x190x339	A453 3400 VT	172.75 €
13.2	13.2x101x182	A453 1320 VT	31.61 €	34.5	34.5x190x339	A453 3450 VT	177.59 €
13.5	13.5x108x189	A453 1350 VT	31.61 €	35.0	35x190x339	A453 3500 VT	177.59 €
13.8	13.8x108x189	A453 1380 VT	32.25 €	35.5	35.5x190x339	A453 3550 VT	193.16 €
14.0	14.0x108x189	A453 1400 VT	32.25 €	36.0	36x195x344	A453 3600 VT	193.16 €
14.5	14.5x114x212	A453 1450 VT	30.51 €	36.5	36.5x195x344	A453 3650 VT	209.43 €
15.0	15x114x212	A453 1500 VT	32.61 €	37.0	37x195x344	A453 3700 VT	209.43 €
15.5	15.5x120x218	A453 1550 VT	34.92 €	37.5	37.5x195x344	A453 3750 VT	223.57 €
16.0	16.0x120x218	A453 1600 VT	34.92 €	38.0	38x200x349	A453 3800 VT	223.57 €
16.5	16.5x125x223	A453 1650 VT	37.84 €	38.5	38.5x200x349	A453 3850 VT	242.33 €
17.0	17x125x223	A453 1700 VT	39.61 €	39.0	39x200x349	A453 3900 VT	242.33 €
17.5	17.5x130x228	A453 1750 VT	40.08 €	39.5	39.5x200x349	A453 3950 VT	257.05 €
18.0	18.0x130x228	A453 1800 VT	42.24 €	40.0	40x200x349	A453 4000 VT	257.05 €
18.5	18.5x135x233	A453 1850 VT	45.87 €	40.5	40.5x205x354	A453 4050 VT	275.46 €
19.0	19x135x233	A453 1900 VT	45.87 €	41.0	41x205x354	A453 4100 VT	275.46 €
19.5	19.5x140x238	A453 1950 VT	52.37 €	41.5	41.5x205x354	A453 4150 VT	293.81 €
20.0	20.0x140x238	A453 2000 VT	56.08 €	42.0	42x205x354	A453 4200 VT	293.81 €
20.5	20.5x145x243	A453 2050 VT	51.42 €	42.5	42.5x205x354	A453 4250 VT	319.57 €
21.0	21x145x243	A453 2100 VT	54.85 €	43.0	43x210x359	A453 4300 VT	319.57 €
21.5	21.5x150x248	A453 2150 VT	61.13 €	43.5	43.5x210x359	A453 4350 VT	330.44 €
22.0	22.0x150x248	A453 2200 VT	59.65 €	44.0	44x210x359	A453 4400 VT	330.44 €
22.5	22.5x155x253	A453 2250 VT	65.31 €	44.5	44.5x210x359	A453 4450 VT	348.86 €
23.0	23x155x253	A453 2300 VT	71.67 €	45.0	45x210x359	A453 4500 VT	348.86 €
23.5	23.5x155x276	A453 2350 VT	70.85 €	45.5	45.5x215x364	A453 4550 VT	359.82 €
24.0	24x160x281	A453 2400 VT	74.10 €	46.0	46x215x364	A453 4600 VT	359.82 €
24.5	24.5x160x281	A453 2450 VT	77.14 €	46.5	46.5x215x364	A453 4650 VT	381.92 €
25.0	25.0x160x281	A453 2500 VT	82.31 €	47.0	47x215x364	A453 4700 VT	381.92 €
25.5	25.5x165x286	A453 2550 VT	85.25 €	47.5	47.5x215x364	A453 4750 VT	396.57 €
26.0	26x165x286	A453 2600 VT	91.62 €	48.0	48x220x369	A453 4800 VT	396.57 €
26.5	26.5x165x286	A453 2650 VT	91.09 €	48.5	48.5x220x369	A453 4850 VT	411.22 €
27.0	27x170x291	A453 2700 VT	94.02 €	49.0	49x220x369	A453 4900 VT	411.22 €
27.5	27.5x170x291	A453 2750 VT	96.90 €	49.5	49.5x220x369	A453 4950 VT	425.93 €
28.0	28x170x291	A453 2800 VT	103.64 €	50.0	50x220x369	A453 5000 VT	425.93 €
28.5	28.5x175x296	A453 2850 VT	110.54 €	50.5	50.5x225x374	A453 5050 VT	506.78 €
29.0	29x175x296	A453 2900 VT	110.54 €	51.0	51x225x412	A453 5100 VT	506.78 €
29.5	29.5x175x296	A453 2950 VT	115.24 €	52.0	52x225x412	A453 5200 VT	550.86 €
30.0	30x175x296	A453 3000 VT	112.31 €	53.0	53x225x412	A453 5300 VT	572.77 €
30.5	30.5x180x301	A453 3050 VT	127.10 €	54.0	54x230x417	A453 5400 VT	594.82 €
31.0	31x180x301	A453 3100 VT	132.95 €	55.0	55x230x417	A453 5500 VT	602.26 €
31.5	31.5x180x301	A453 3150 VT	133.85 €	56.0	56x230x417	A453 5600 VT	624.19 €
32.0	32x185x334	A453 3200 VT	139.48 €	57.0	57x235x422	A453 5700 VT	646.22 €
32.5	32.5x185x334	A453 3250 VT	155.01 €	58.0	58x235x422	A453 5800 VT	697.70 €
33.0	33x185x334	A453 3300 VT	155.01 €	59.0	59x235x422	A453 5900 VT	727.00 €
33.5	33.5x185x334	A453 3350 VT	172.75 €	60.0	60x235x422	A453 6000 VT	749.12 €



réf. A452

conditions de coupe recommandées p. 36

Ø perçage	Dimensions	Réf.	Prix unitaire TARIF H.T.
13.0	13x101x182	A452 1300 T	74.41 €
13.5	13.5x108x189	A452 1350 T	76.08 €
14.0	14x108x189	A452 1400 T	77.43 €
14.5	14.5x114x212	A452 1450 T	78.29 €
15.0	15x114x212	A452 1500 T	83.82 €
15.5	15.5x120x218	A452 1550 T	93.03 €
16.0	16x120x218	A452 1600 T	92.97 €
16.5	16.5x125x223	A452 1650 T	100.71 €
17.0	17x125x223	A452 1700 T	105.56 €
17.5	17.5x130x228	A452 1750 T	106.65 €
18.0	18x130x228	A452 1800 T	112.49 €
18.5	18.5x135x233	A452 1850 T	117.81 €
19.0	19x135x233	A452 1900 T	118.28 €
19.5	19.5x140x238	A452 1950 T	125.69 €
20.0	20x140x238	A452 2000 T	134.52 €
20.5	20.5x145x243	A452 2050 T	157.40 €
21.0	21x145x243	A452 2100 T	160.63 €
21.5	21.5x150x248	A452 2150 T	168.76 €
22.0	22x150x248	A452 2200 T	164.73 €
22.5	22.5x155x253	A452 2250 T	203.17 €
23.0	23x155x253	A452 2300 T	215.91 €
23.5	23.5x155x276	A452 2350 T	227.13 €
24.0	24x160x281	A452 2400 T	237.51 €
24.5	24.5x160x281	A452 2450 T	248.96 €
25.0	25x160x281	A452 2500 T	264.64 €
25.5	25.5x165x286	A452 2550 T	272.30 €
26.0	26x165x286	A452 2600 T	274.80 €
26.5	26.5x165x286	A452 2650 T	285.43 €
27.0	27x170x291	A452 2700 T	295.59 €
27.5	27.5x170x291	A452 2750 T	310.53 €
28.0	28x170x291	A452 2800 T	318.15 €
28.5	28.5x175x296	A452 2850 T	331.68 €
29.0	29x175x296	A452 2900 T	331.68 €
29.5	29.5x175x296	A452 2950 T	383.59 €
30.0	30x175x296	A452 3000 T	373.83 €

FORETS HSS DIN 1870/1 CÔNE MORSE LONGS TRAITEMENT VAPEUR



réf. A455

conditions de coupe recommandées p. 36

Ø perçage	Dimensions	Réf.	Prix unitaire TARIF H.T.	Ø perçage	Dimensions	Réf.	Prix unitaire TARIF H.T.
13.0	13x205x310	A455 1300 VT	92.90 €	27.0	27x305x460	A455 2700 VT	336.14 €
13.5	13.5x220x325	A455 1350 VT	94.98 €	27.5	27.5x305x460	A455 2750 VT	347.58 €
14.0	14x220x325	A455 1400 VT	99.71 €	28.0	28x305x460	A455 2800 VT	345.42 €
14.5	14.5x220x340	A455 1450 VT	116.20 €	28.5	28.5x305x460	A455 2850 VT	386.29 €
15.0	15x220x340	A455 1500 VT	119.56 €	29.0	29x305x460	A455 2900 VT	391.41 €
15.5	15.5x230x355	A455 1550 VT	125.22 €	29.5	29.5x305x460	A455 2950 VT	404.66 €
16.0	16x230x355	A455 1600 VT	130.53 €	30.0	30x305x460	A455 3000 VT	418.12 €
16.5	16.5x230x355	A455 1650 VT	140.49 €	30.5	30.5x320x480	A455 3050 VT	438.32 €
17.0	17x230x355	A455 1700 VT	148.37 €	31.0	31x320x480	A455 3100 VT	458.52 €
17.5	17.5x245x370	A455 1750 VT	155.04 €	32.0	32x320x505	A455 3200 VT	500.80 €
18.0	18x245x370	A455 1800 VT	164.05 €	33.0	33x320x505	A455 3300 VT	583.46 €
18.5	18.5x245x370	A455 1850 VT	168.24 €	34.0	34x340x530	A455 3400 VT	617.59 €
19.0	19x245x370	A455 1900 VT	177.46 €	35.0	35x340x530	A455 3500 VT	623.72 €
19.5	19.5x260x385	A455 1950 VT	187.15 €	36.0	36x340x530	A455 3600 VT	656.37 €
20.0	20x260x385	A455 2000 VT	193.81 €	37.0	37x340x530	A455 3700 VT	691.37 €
20.5	20.5x260x385	A455 2050 VT	199.34 €	38.0	38x360x555	A455 3800 VT	726.38 €
21.0	21x260x385	A455 2100 VT	202.64 €	39.0	39x360x555	A455 3900 VT	744.02 €
21.5	21.5x270x405	A455 2150 VT	206.67 €	40.0	40x360x555	A455 4000 VT	793.37 €
22.0	22x270x405	A455 2200 VT	213.86 €	41.0	41x360x555	A455 4100 VT	840.35 €
22.5	22.5x270x405	A455 2250 VT	223.57 €	42.0	42x360x555	A455 4200 VT	872.59 €
23.0	23x270x405	A455 2300 VT	230.84 €	43.0	43x385x585	A455 4300 VT	990.61 €
23.5	23.5x270x425	A455 2350 VT	249.21 €	44.0	44x385x585	A455 4400 VT	1 028.78 €
24.0	24x290x440	A455 2400 VT	295.87 €	45.0	45x385x585	A455 4500 VT	1 084.78 €
24.5	24.5x290x440	A455 2450 VT	309.53 €	46.0	46x385x585	A455 4600 VT	1 138.78 €
25.0	25x290x440	A455 2500 VT	317.28 €	47.0	47x385x585	A455 4700 VT	1 199.37 €
25.5	25.5x290x440	A455 2550 VT	322.27 €	48.0	48x405x605	A455 4800 VT	1 317.45 €
26.0	26x290x440	A455 2600 VT	326.57 €	49.0	49x405x605	A455 4900 VT	1 383.14 €
26.5	26.5x290x440	A455 2650 VT	369.73 €	50.0	50x405x605	A455 5000 VT	1 446.50 €



réf. A456

conditions de coupe recommandées p. 36

Ø perçage	Dimensions	Réf.	Prix unitaire TARIF H.T.	Ø perçage	Dimensions	Réf.	Prix unitaire TARIF H.T.
13.0	13x260x395	A456 1300 VT	133.08 €	27.0	27x385x580	A456 2700 VT	524.55 €
13.5	13.5x275x410	A456 1350 VT	136.18 €	27.5	27.5x385x580	A456 2750 VT	542.46 €
14.0	14x275x410	A456 1400 VT	142.86 €	28.0	28x385x580	A456 2800 VT	526.11 €
14.5	14.5x275x425	A456 1450 VT	166.62 €	28.5	28.5x385x580	A456 2850 VT	588.24 €
15.0	15x275x425	A456 1500 VT	171.26 €	29.0	29x385x580	A456 2900 VT	620.43 €
15.5	15.5x295x445	A456 1550 VT	179.34 €	29.5	29.5x385x580	A456 2950 VT	641.56 €
16.0	16x295x445	A456 1600 VT	187.21 €	30.0	30x385x580	A456 3000 VT	662.76 €
16.5	16.5x295x445	A456 1650 VT	201.63 €	31.0	31x410x610	A456 3100 VT	676.02 €
17.0	17x295x445	A456 1700 VT	212.59 €	32.0	32x410x635	A456 3200 VT	738.44 €
17.5	17.5x310x465	A456 1750 VT	222.15 €	33.0	33x410x635	A456 3300 VT	812.08 €
18.0	18x310x465	A456 1800 VT	235.08 €	34.0	34x430x665	A456 3400 VT	812.08 €
18.5	18.5x310x465	A456 1850 VT	241.14 €	35.0	35x430x665	A456 3500 VT	812.08 €
19.0	19x310x465	A456 1900 VT	254.20 €	36.0	36x430x665	A456 3600 VT	830.87 €
19.5	19.5x325x490	A456 1950 VT	322.29 €	37.0	37x430x665	A456 3700 VT	850.04 €
20.0	20x325x490	A456 2000 VT	333.75 €	38.0	38x460x695	A456 3800 VT	866.87 €
20.5	20.5x325x490	A456 2050 VT	343.37 €	39.0	39x460x695	A456 3900 VT	951.36 €
21.0	21x325x490	A456 2100 VT	349.17 €	40.0	40x460x695	A456 4000 VT	1 014.51 €
21.5	21.5x345x515	A456 2150 VT	347.30 €	41.0	41x460x695	A456 4100 VT	1 074.62 €
22.0	22x345x515	A456 2200 VT	359.28 €	42.0	42x460x695	A456 4200 VT	1 115.89 €
22.5	22.5x345x515	A456 2250 VT	354.44 €	43.0	43x490x735	A456 4300 VT	1 266.62 €
23.0	23x345x515	A456 2300 VT	366.15 €	44.0	44x490x735	A456 4400 VT	1 315.56 €
23.5	23.5x345x535	A456 2350 VT	395.17 €	45.0	45x490x735	A456 4500 VT	1 387.19 €
24.0	24x365x555	A456 2400 VT	404.93 €	46.0	46x490x735	A456 4600 VT	1 456.13 €
24.5	24.5x365x555	A456 2450 VT	423.45 €	47.0	47x490x735	A456 4700 VT	1 533.67 €
25.0	25x365x555	A456 2500 VT	438.65 €	48.0	48x510x765	A456 4800 VT	1 684.69 €
25.5	25.5x365x555	A456 2550 VT	447.80 €	49.0	49x510x765	A456 4900 VT	1 768.69 €
26.0	26x365x555	A456 2600 VT	447.80 €	50.0	50x510x765	A456 5000 VT	1 849.54 €
26.5	26.5x365x555	A456 2650 VT	507.06 €				



réf. A461 Forets HSS Co8 NC 90°

réf. A463 Forets HSS Co8 NC 120°

Ø perçage	Dimensions	Réf.	Prix unitaire TARIF H.T.
3.0	3x12x12x46	A461 0300	7.77 €
4.0	4x12x12x55	A461 0400	8.17 €
5.0	5.0x15x60	A461 0500	8.28 €
6.0	6x20x66	A461 0600	8.98 €
8.0	8.0x25x79	A461 0800	10.52 €
10.0	10.0x25x89	A461 1000	13.50 €
12.0	12.0x30x102	A461 1200	19.04 €
16.0	16x35x115	A461 1600	33.39 €
20.0	20x40x131	A461 2000	55.48 €

Ø perçage	Dimensions	Réf.	Prix unitaire TARIF H.T.
3.0	3x12x12x46	A463 0300	7.77 €
4.0	4x12x12x55	A463 0400	8.17 €
5.0	5x15x15x60	A463 0500	8.28 €
6.0	6x20x66	A463 0600	8.98 €
8.0	8x25x79	A463 0800	10.52 €
10.0	10x25x89	A463 1000	13.50 €
12.0	12x30x102	A463 1200	19.04 €
16.0	16x35x115	A463 1600	33.39 €
20.0	20x40x131	A463 2000	55.48 €

Conditions de coupe recommandées

unité = mm

Matière usinée	Aciers au carbone		Aciers au carbone		Aciers alliés Aciers à outil Acier trempés		Aciers inox		Aluminium et non-ferreux	
	N	S	N	S	N	S	N	S	N	S
DIAMETRE										
3	2 460	0.06	2 110	0.06	1 080	0.06	940	0.06	7 040	0.14
4	1 850	0.07	1 580	0.07	800	0.07	700	0.07	5 280	0.15
5	1 510	0.08	1 300	0.08	670	0.08	580	0.08	4 400	0.17
6	1 170	0.09	1 030	0.09	540	0.09	460	0.09	3 520	0.19
8	880	0.11	790	0.11	400	0.11	350	0.11	2 640	0.22
10	700	0.12	630	0.12	320	0.12	290	0.12	2 110	0.25
12	590	0.14	530	0.14	260	0.14	240	0.14	1 760	0.28
16	460	0.20	400	0.20	200	0.20	180	0.20	1 320	0.33
20	350	0.24	320	0.24	150	0.24	140	0.24	1 060	0.45

N = R.P.M.

S = Avance par tour (mm/tr).



réf. A480

Ø perçage	Dimensions	Réf.	Prix unitaire TARIF H.T.
1.0	1x3.15x1.3x31.5	A480 0100	5.23 €
1.25	1.25x3.15x1.6x31.5	A480 0125	5.23 €
1.6	1.6x4x2x35.5	A480 0160	5.23 €
2.0	2.0x5x2.5x40	A480 0200	5.53 €
2.5	2.5x6.3x3.1x45	A480 0250	6.18 €
3.15	3.15x8x3.9x50	A480 0315	6.50 €
4.0	4.0x10x5x56	A480 0400	8.67 €
5.0	5x12.5x6.3x63	A480 0500	14.40 €

Conditions de coupe recommandées

unité = mm

Matière usinée	Aciers doux		Aciers Alliés				Aciers inox	
DURETE	< 700 N/mm ²		~ HRc 23		~ HRc 32			
DIAMETRE	vitesse	avance	vitesse	avance	vitesse	avance	vitesse	avance
2.0	30 ~ 45	0.02~0.05	25 ~ 30	0.02~0.05	15 ~ 25	0.01~0.03	6 ~ 10	0.01~0.03
3.0		0.06		0.06		0.04		0.04
6.0		0.08		0.08		0.06		0.06
10.0		0.15		0.15		0.10		0.10

Vitesse (Ø queue) = m/min.
Avance (Ø foret) = mm/rev.

FORETS HSS et HSS Co8 DIN1897, DIN338, DIN340, DIN1869

ref. A421, A425, A423, A427, A428

unité = mm

Matière usinée	Aciers au carbone		Aciers au carbone		Aciers au carbone		Aciers alliés		Aciers alliés		Aciers inox		Alliages titane	
DURETE			~ HRC23		~ HRC23 ~ 28		HRC23 ~ 34		HRC34 ~ 38		HRC23			
RESISTANCE	~ 570 N/mm2		~ 830 N/mm2		830 ~ 950 N/mm2		830 ~ 1110 N/mm2		1110 ~ 1260 N/mm2		830 N/mm2		410 N/mm2	
DIAMETRE	N	S	N	S	N	S	N	S	N	S	N	S	N	S
2.5	3 380	0.025	2 550	0.025	1 900	0.015	2 380	0.020	1 400	0.015	2 550	0.025	1 400	0.020
3	2 700	0.050	2 000	0.050	1 500	0.025	1 880	0.050	1 100	0.020	2 000	0.050	1 100	0.025
5	1 700	0.063	1 280	0.063	960	0.038	1 190	0.063	700	0.025	1 280	0.063	700	0.038
8	1 050	0.130	780	0.130	590	0.076	730	0.130	430	0.038	780	0.130	430	0.076
11	750	0.150	560	0.150	425	0.076	520	0.180	310	0.050	560	0.150	430	0.076
19	440	0.230	330	0.230	255	0.130	300	0.230	180	0.050	330	0.230	180	0.130
31	260	0.280	195	0.280	145	0.180	180	0.180	107	0.076	195	0.280	107	0.180

Matière usinée	Aciers à outil		Fontes		Alliages Aluminium		Alliages magnésium		Alliages de zinc		Plastiques	
DURETE			~ HRC21									
RESISTANCE	~ 270 N/mm2		~ 800 N/mm2									
DIAMETRE	N	S	N	S	N	S	N	S	N	S	N	S
2.5	3 180	0.042	2 250	0.025	6 400	0.038	8 600	0.038	6 400	0.038	3 380	0.025
3	2 500	0.050	2 000	0.050	5 000	0.063	6 800	0.063	5 000	0.063	2 700	0.050
5	1 590	0.063	1 280	0.063	3 200	0.076	4 300	0.076	3 200	0.076	1 700	0.063
8	970	0.130	780	0.130	2 000	0.180	2 600	0.180	2 000	0.180	1 050	0.130
11	700	0.180	560	0.150	1 400	0.200	1 900	0.200	1 400	0.200	750	0.150
19	440	0.230	330	0.230	820	0.300	1 100	0.300	820	0.300	440	0.230
31	240	0.300	195	0.280	490	0.380	660	0.380	490	0.380	260	0.280

N = R.P.M.
S = Avance par tour (mm/tr).

FORETS HSSCo5 TiN

ref. A402, A403

unité = mm

Matière usinée	Aciers au carbone		Aciers au carbone		Aciers alliés		Aciers inox		Alliages titane		Aluminium et Zinc		Alliages magnésium	
DURETE			~ HRC23		~ HRC23 ~ 34		HRC23							
RESISTANCE	~ 570 N/mm2		~ 830 N/mm2		810 ~ 1110 N/mm2		~ 830 N/mm2		~ 410 N/mm2					
DIAMETRE	N	S	N	S	N	S	N	S	N	S	N	S	N	S
1	14 000	0.02	12 500	0.02	7 700	0.02	7 000	0.02	8 050	0.02	30 000	0.02	11 500	0.03
2	7 000	0.06	6 100	0.06	3 850	0.06	3 500	0.06	4 050	0.06	15 000	0.06	5 800	0.09
3	4 650	0.10	4 100	0.08	2 550	0.08	2 350	0.08	2 700	0.08	9 900	0.10	3 850	0.13
4	3 500	0.11	3 050	0.11	1 950	0.10	1 750	0.10	2 000	0.09	7 450	0.11	2 900	0.15
5	2 800	0.12	2 450	0.11	1 550	0.10	1 400	0.10	1 600	0.10	5 950	0.12	2 300	0.17
6	2 350	0.14	2 050	0.13	1 300	0.12	1 150	0.12	1 350	0.12	4 950	0.14	1 950	0.19
7	2 000	0.16	1 750	0.15	1 100	0.14	1 000	0.14	1 150	0.14	4 250	0.16	1 650	0.22
8	1 750	0.18	1 550	0.18	960	0.15	875	0.15	1 000	0.15	3 700	0.18	1 450	0.24
9	1 550	0.20	1 350	0.22	855	0.18	780	0.18	895	0.17	3 300	0.20	1 280	0.27
10	1 400	0.21	1 250	0.22	770	0.18	700	0.18	805	0.18	3 000	0.23	1 150	0.29
11	1 250	0.22	1 100	0.22	700	0.18	650	0.18	730	0.18	2 700	0.23	1 050	0.30
12	1 150	0.23	1 000	0.22	650	0.20	585	0.20	670	0.20	2 480	0.23	960	0.31
13	1 050	0.23	950	0.22	595	0.20	540	0.20	620	0.20	2 300	0.23	890	0.31

N = R.P.M.
S = Avance par tour (mm/tr).

FORETS HSS-E DIN345

ref. A452

unité = mm

Matière usinée	Aciers au carbone		Aciers au carbone		Aciers au carbone		Aciers alliés		Aciers alliés		Aciers inox		Fontes	
	~ HRC23		~ HRC23		HRC23 ~ 28		HRC23 ~ 34		HRC34 ~ 38		HRC23		HRC21	
RESISTANCE	~ 570 N/mm2		~ 830 N/mm2		830 ~ 950 N/mm2		830 ~ 1110 N/mm2		1110 ~ 1260 N/mm2		830 N/mm2		800 N/mm2	
DIAMETRE	N	S	N	S	N	S	N	S	N	S	N	S	N	S
13	785	0.17	575	0.17	445	0.09	540	0.20	325	0.05	785	0.17	785	0.17
14	720	0.18	530	0.18	410	0.10	500	0.20	300	0.05	720	0.18	720	0.18
16	635	0.20	475	0.20	365	0.11	445	0.22	265	0.05	635	0.20	635	0.20
18	550	0.22	420	0.22	320	0.12	390	0.23	230	0.05	550	0.22	550	0.22
20	500	0.23	380	0.23	290	0.13	355	0.23	210	0.06	500	0.23	500	0.23
22	450	0.24	340	0.24	260	0.14	320	0.23	190	0.06	450	0.24	450	0.24
24	420	0.25	320	0.25	240	0.15	295	0.23	175	0.07	420	0.25	420	0.25
26	390	0.26	300	0.26	220	0.16	270	0.23	160	0.07	390	0.26	390	0.26
28	360	0.27	275	0.27	205	0.17	250	0.23	150	0.07	360	0.27	360	0.27
30	330	0.28	250	0.28	190	0.18	230	0.23	140	0.08	330	0.28	330	0.28

N = R.P.M.

S = Avance par tour (mm/tr).

FORETS HSS DIN345, DIN341, DIN1870

ref. A453, A455, A456

unité = mm

Matière usinée	Aciers au carbone		Aciers au carbone		Aciers au carbone		Aciers alliés		Aciers alliés		Aciers inox		Alliages titane	
	~ HRC23		~ HRC23		~ HRC23 ~ 28		HRC23 ~ 34		HRC34 ~ 38		HRC23		410 N/mm2	
RESISTANCE	~ 570 N/mm2		~ 830 N/mm2		830 ~ 950 N/mm2		830 ~ 1110 N/mm2		1110 ~ 1260 N/mm2		830 N/mm2		410 N/mm2	
DIAMETRE	N	S	N	S	N	S	N	S	N	S	N	S	N	S
13	645	0.17	480	0.17	370	0.09	440	0.20	265	0.05	480	0.17	265	0.09
19	440	0.23	330	0.23	255	0.13	300	0.23	180	0.05	330	0.23	180	0.13
32	260	0.28	195	0.28	145	0.18	180	0.18	107	0.08	195	0.28	107	0.18
50	165	0.33	125	0.33	93	0.20	115	0.20	68	0.08	125	0.33	68	0.20
60	140	0.40	105	0.40	78	0.23	95	0.23	57	0.10	105	0.40	57	0.23

Matière usinée	Aciers à outil		Fontes		Alliages Aluminium		Alliages magnésium		Alliages de zinc		Plastiques	
	~ HRC21		~ HRC21		~ HRC21		~ HRC21		~ HRC21		~ HRC21	
RESISTANCE	~ 270 N/mm2		~ 800 N/mm2		~ 800 N/mm2		~ 800 N/mm2		~ 800 N/mm2		~ 800 N/mm2	
DIAMETRE	N	S	N	S	N	S	N	S	N	S	N	S
13	645	0.17	480	0.17	1 200	0.26	1 600	0.26	1 200	0.26	645	0.17
19	440	0.23	330	0.23	820	0.30	1 100	0.30	820	0.30	440	0.23
32	240	0.30	195	0.28	490	0.38	660	0.38	490	0.38	260	0.28
50	150	0.43	125	0.33	310	0.46	415	0.46	310	0.46	165	0.33
60	125	0.48	105	0.40	260	0.50	345	0.50	260	0.50	140	0.40

N = R.P.M.

S = Avance par tour (mm/tr).

JEU DE TARAUDS À MAIN

				LISTE DES MATIÈRES					
				aciers jusqu'à 800 N/mm ²	aciers jusqu'à 1200 N/mm ²	aciers INOX	fontes	ALU	plastiques
B700	Jeu de tarauds à main HSS DIN 352		p.40	●			●	●	●
B703	Jeu de tarauds à main HSS-E DIN 352 traités VAP		p.41		●	●			
B704	Jeu de tarauds à main HSS DIN 2181 métriques fins droits		p.42	●			●	●	●
B705	Jeu de tarauds à main HSS UNC DIN 351		p.43	●			●	●	●
B706	Jeu de tarauds à main HSS UNF DIN 2181		p.44	●			●	●	●
B707	Jeu de tarauds à main HSS BSW DIN 351		p.45	●			●	●	●
B720	Jeu de tarauds à main HSS GAZ DIN 5157		p.46	●			●	●	●

suite page suivante

● utilisation conseillée pour la matière concernée

ACCESSOIRES TARAUDS

Filières [page 64](#)

Tourne à gauche [page 64](#)

Porte-filières [page 64](#)

DONNÉES TECHNIQUES

vitesse de coupe recommandées









[page 65](#)

conditions de coupe recommandées

[pages 65 et 66](#)

SOMMAIRE TARAUDS

TARAUDS MACHINE GAZ

		LISTE DES MATIÈRES							
		aciers jusqu'à 800 N/mm ²	aciers jusqu'à 1200 N/mm ²	aciers INOX	fontes	ALU	plastiques		
B215	Taraud HSS-E droit UNC		p.47	●			●	●	●
B419	Taraud HSS-E hélicoïdal UNC		p.48	●			●	●	●
B218	Taraud HSS-E droit UNF		p.49	●			●	●	●
B423	Taraud HSS-E hélicoïdal UNF		p.50	●			●	●	●
B221	Taraud HSS-E droit BSW		p.51	●			●	●	●
B427	Taraud HSS-E hélicoïdal BSW		p.52	●			●	●	●
B721	Taraud HSS-E droit GAZ		p.53	●			●	●	●
B722	Taraud HSS-E hélicoïdal GAZ		p.54	●			●	●	●

suite page suivante

● utilisation conseillée pour la matière concernée

ACCESSOIRES TARAUDS

Filières [page 64](#)

Tourne à gauche [page 64](#)

Porte-filières [page 64](#)

DONNÉES TECHNIQUES

vitesse de coupe recommandées









[page 65](#)

conditions de coupe recommandées

[pages 65 et 66](#)

SOMMAIRE TARAUDS

TARAUDS MACHINE MÉTRIQUES

				LISTE DES MATIÈRES					
				aciers jusqu'à 800 N/mm ²	aciers jusqu'à 1200 N/mm ²	aciers INOX	fontes	ALU	plastiques
B201	Taraud HSS-E droit acier 80 KG Din 371		p.55	●			●	●	●
B403	Taraud HSS-E hélicoïdal acier 80 KG DIN 371/376		p.56	●			●	●	●
B202	Taraud HSS-E droit acier 80 KG Din 376		p.57	●			●	●	●
B213	Taraud HSS-E droit acier 80 Kg métrique pas fin		p.58	●			●	●	●
B415	Taraud HSS-E hélicoïdal acier 80 Kg métrique pas fin		p.59	●			●	●	●
B206	Taraud HSS-E droit acier 120 Kg DIN 371/376 revêtu TiAIN		p.60		●				
B408	Taraud HSS-E hélicoïdal acier 120 Kg DIN 371/376 revêtu TiAIN		p.61		●				
B207	Taraud HSS-E droit INOX DIN 371/376 traité VAP		p.62	●		●			
B409	Taraud HSS-E hélicoïdal INOX DIN 371/376 traité VAP		p.63	●		●			

● utilisation conseillée pour la matière concernée

ACCESSOIRES TARAUDS

Filières [page 64](#)

Tourne à gauche [page 64](#)

Porte-filières [page 64](#)

DONNÉES TECHNIQUES

vitesse de coupe recommandées

[page 65](#)

conditions de coupe recommandées

[pages 65 et 66](#)



réf. B700

TAILLE	∅ perçage	Dimensions	Réf.	Prix unitaire TARIF H.T.
M2	1.6	M2x0.4x6Hx36	B700 M020	31.50 €
M2.5	2.05	M2.5x0.45x6Hx40	B700 M025	26.05 €
M3	2.5	M3x0.50x6Hx40	B700 M030	18.40 €
M4	3.3	M4x0.70x6Hx45	B700 M040	18.40 €
M5	4.2	M5x0.80x6Hx52	B700 M050	18.91 €
M6	5	M6x1.00x6Hx56	B700 M060	19.49 €
M8	6.8	M8x1.25x6Hx63	B700 M080	25.41 €
M10	8.5	M10x1.50x6Hx70	B700 M100	32.49 €
M12	10.2	M12x1.75x6Hx80	B700 M120	40.56 €
M14	12	M14x2.0x6Hx80	B700 M140	51.47 €
M16	14	M16x2.00x6Hx80	B700 M160	69.13 €
M18	15.5	M18x2.5x6Hx95	B700 M180	82.64 €
M20	17.5	M20x2.50x6Hx95	B700 M200	100.17 €
M22	19.5	M22x2.50x6Hx100	B700 M220	124.32 €
M24	21	M24x3.00x6Hx110	B700 M240	143.28 €
M27	24	M27x3.00x6Hx110	B700 M270	194.15 €
M30	26.5	M30x3.50x6Hx125	B700 M300	248.64 €
M33	29.5	M33x3.5x6Hx125	B700 M330	330.54 €
M36	32	M36x4.00x6Hx150	B700 M360	394.07 €
M39	35	M39x4.0x6Hx150	B700 M390	504.16 €
M42	37.5	M42x4.5x6Hx150	B700 M420	563.96 €
M45	40.5	M45x4.5x6Hx160	B700 M450	655.51 €
M48	43	M48x5.0x6Hx180	B700 M480	739.59 €
M52	47	M52x5.0x6Hx180	B700 M520	900.07 €

Ces tarauds sont livrés par série de 3 : ébauche, intermédiaire et finition. Seul le taraud lisse de finition de la série possède les dimensions finales du filet à obtenir.

JEU DE TARAUDS À MAIN HSS-E DIN 352 TRAITÉS VAP



réf. B703

TAILLE	∅ perçage	Dimensions	Réf.	Prix unitaire TARIF H.T.
M3	2.5	M3x0.5x6HXx40	B703 M030 V	54.61 €
M4	3.3	M4x0.7x6HXx45	B703 M040 V	54.61 €
M5	4.2	M5x0.8x6HXx52	B703 M050 V	60.05 €
M6	5	M6x1.0x6HXx56	B703 M060 V	60.64 €
M8	6.8	M8x1.25x6HXx63	B703 M080 V	66.03 €
M10	8.5	M10x1.5x6HXx70	B703 M100 V	86.70 €
M12	10.2	M12x1.75x6HXx80	B703 M120 V	109.94 €
M14	12	M14x2.00x6HXx80	B703 M140 V	141.71 €
M16	14	M16x2.0x6HXx80	B703 M160 V	173.01 €
M18	15.5	M18x2.5x6HXx95	B703 M180 V	219.22 €
M20	17.5	M20x2.5x6HXx95	B703 M200 V	265.71 €

Ces tarauds sont livrés par série de 3 : ébauche, intermédiaire et finition. Seul le taraud lisse de finition de la série possède les dimensions finales du filet à obtenir.



réf. B704

TAILLE	Ø perçage	Dimensions	Réf.	Prix unitaire TARIF H.T.	TAILLE	Ø perçage	Dimensions	Réf.	Prix unitaire TARIF H.T.
M3	2.65	M3x0.35x6Hx42	B704 M030 035	12.54 €	M16	15	M16x1.5x6Hx70	B704 M160 150	49.43 €
M4	3.5	M4x0.5x6Hx48	B704 M040 050	17.46 €	M18	16	M18x1.0x6Hx80	B704 M180 100	67.75 €
M5	4.5	M5x0.5x6Hx52	B704 M050 050	17.46 €	M18	16.5	M18x1.5x6Hx80	B704 M180 150	62.81 €
M6	5.2	M6x0.5x6Hx56	B704 M060 050	18.85 €	M18	17	M18x2x6Hx80	B704 M180 200	69.05 €
M6	5.5	M6x0.75x6Hx56	B704 M060 075	16.87 €	M20	18	M20x1x6Hx80	B704 M200 100	82.44 €
M7	6.2	M7x0.75x6Hx56	B704 M070 075	22.78 €	M20	18.5	M20x1.5x6Hx80	B704 M200 150	68.25 €
M8	7	M8x0.50x6Hx63	B704 M080 050	24.74 €	M20	19	M20x2x6Hx80	B704 M200 200	82.44 €
M8	7.2	M8x0.75x6Hx63	B704 M080 075	22.78 €	M22	20	M22x1.0x6Hx80	B704 M220 100	110.99 €
M8	7.5	M8x1.00x6Hx63	B704 M080 100	20.94 €	M22	20.5	M22x1.5x6Hx80	B704 M220 150	100.90 €
M9	8	M9x1.0x6Hx63	B704 M090 125	30.00 €	M22	21	M22x2x6Hx80	B704 M220 200	110.99 €
M10	8.8	M10x0.75x6Hx63	B704 M100 075	30.00 €	M24	22	M24x1x6Hx90	B704 M240 100	133.51 €
M10	9	M10x1.0x6Hx63	B704 M100 100	24.42 €	M24	22.5	M24x1.5x6Hx90	B704 M240 150	121.36 €
M10	9.2	M10x1.25x6Hx70	B704 M100 125	24.42 €	M24	23	M24x2.0x6Hx90	B704 M240 200	127.39 €
M11	10	M11x1.0x6Hx63	B704 M110 100	29.22 €	M25	23.5	M25x1.0x6Hx90	B704 M250 100	130.16 €
M12	10.5	M12x1.00x6Hx70	B704 M120 100	29.46 €	M25	24	M25x1.5x6Hx90	B704 M250 150	118.34 €
M12	10.8	M12x1.25x6Hx70	B704 M120 125	29.22 €	M26	24.5	M26x1x6Hx90	B704 M260 100	109.22 €
M12	11	M12x1.5x6Hx70	B704 M120 150	28.87 €	M26	25	M26x1.5x6Hx90	B704 M260 150	121.36 €
M13	11.5	M13x1.0x6Hx70	B704 M130 100	41.02 €	M27	25	M27x1x6Hx90	B704 M270 100	183.91 €
M13	12	M13x1.5x6Hx70	B704 M130 150	41.02 €	M27	25.5	M27x1.5x6Hx90	B704 M270 150	153.33 €
M14	12.5	M14x1.0x6Hx70	B704 M140 100	44.90 €	M27	26	M27x2x6Hx90	B704 M270 200	167.24 €
M14	12.8	M14x1.25x6Hx70	B704 M140 125	40.15 €	M28	26	M28x1.5x6Hx90	B704 M280 150	153.33 €
M14	13	M14x1.50x6Hx70	B704 M140 150	36.11 €	M28	26.5	M28x2.0x6Hx90	B704 M280 200	174.59 €
M15	13.5	M15x1.0x6Hx70	B704 M150 100	54.61 €	M30	28	M30x1x6Hx90	B704 M300 100	195.60 €
M15	14	M15x1.5x6Hx70	B704 M150 150	49.43 €	M30	28.5	M30x1.50x6Hx90	B704 M300 150	172.82 €
M16	14.5	M16x1x6Hx70	B704 M160 100	54.61 €	M30	29	M30x2x6Hx90	B704 M300 200	191.27 €

Ces tarauds sont livrés par série de 2 : ébauche et finition.
Seul le taraud lisse de finition de la série possède les dimensions finales du filet à obtenir.

JEU DE TARAUDS À MAIN HSS UNC DIN 351



réf. B705

TAILLE	∅ perçage	Dimensions	Réf.	Prix unitaire TARIF H.T.
No.2	1.8	No.2x56x2Bx36	B705 C002	53.25 €
No.3	2.1	No.3x48x2Bx40	B705 C003	45.15 €
No.4	2.3	No.4x40x2Bx42	B705 C004	30.12 €
No.5	2.6	No.5x40x2Bx42	B705 C005	23.44 €
No.6	2.85	No.6x32x2Bx45	B705 C006	23.44 €
No.8	3.5	No.8x32x2Bx48	B705 C008	23.44 €
No.10	3.9	No.10x24x2Bx52	B705 C010	22.78 €
No.12	4.5	No.12x24x2Bx56	B705 C012	54.86 €
1/4	5.2	1/4x20x2Bx56	B705 C016	22.32 €
5/16	6.6	5/16x18x2Bx63	B705 C020	31.44 €
3/8	8	3/8x16x2Bx70	B705 C024	36.97 €
7/16	9.4	7/16x14x2Bx70	B705 C028	48.31 €
1/2	10.75	1/2x13x2Bx80	B705 C032	56.98 €
9/16	12.25	9/16x12x2Bx80	B705 C036	128.26 €
5/8	13.5	5/8x11x2Bx90	B705 C040	80.40 €
3/4	16.5	3/4x10x2Bx105	B705 C048	113.99 €
7/8	19.5	7/8x9x2Bx110	B705 C056	214.90 €
1	22.25	1"x8x2Bx110	B705 C064	311.71 €
1*1/8	25	1"1/8x7x2Bx125	B705 C072	414.50 €
1*1/4	28.25	1"1/4x7x2Bx125	B705 C080	499.82 €
1*3/8	30.75	1"3/8x6x2Bx150	B705 C088	702.64 €
1*1/2	34	1"1/2x6x2Bx150	B705 C096	814.47 €
1*3/4	39.5	1"3/4x5x2Bx160	B705 C112	1 117.07 €
2	45.25	2"x4.5x2Bx180	B705 C128	1 490.72 €

Ces tarauds sont livrés par série de 3 : ébauche, intermédiaire et finition. Seul le taraud lisse de finition de la série possède les dimensions finales du filet à obtenir.



réf. B706

TAILLE	∅ perçage	Dimensions	Réf.	Prix unitaire TARIF H.T.
No.4	2.4	No.4x48x2Bx42	B706 F004	25.00 €
No.5	2.7	No.5x44x2Bx42	B706 F005	24.62 €
No.6	3	No.6x40x2Bx45	B706 F006	24.62 €
No.8	3.5	No.8x36x2Bx48	B706 F008	23.44 €
No.10	4.1	No.10x32x2Bx45	B706 F010	15.63 €
No.12	4.7	No.12x28x2Bx56	B706 F012	22.66 €
1/4-28	5.5	1/4x28x2Bx50	B706 F016	15.36 €
5/16-24	6.9	5/16x24x2Bx56	B706 F020	21.53 €
3/8-24	8.5	3/8x24x2Bx56	B706 F024	25.20 €
7/16-20	9.9	7/16x20x2Bx63	B706 F028	33.14 €
1/2-20	11.5	1/2x20x2Bx70	B706 F032	39.05 €
9/16	12.9	9/16x18x2Bx70	B706 F036	56.12 €
5/8	14.5	5/8x18x2Bx70	B706 F040	53.82 €
3/4	17.9	3/4x16x2Bx80	B706 F048	67.09 €
7/8	20.5	7/8x14x2Bx80	B706 F056	85.28 €
1-12	23.25	1"x12x12	B706 F064	109.81 €
1*1/8	26.5	1" 1/8x12x2Bx90	B706 F072	145.06 €

Ces tarauds sont livrés par série de 2 : ébauche et finition.
Seul le taraud lisse de finition de la série possède les dimensions finales du filet à obtenir.



réf. B707

TAILLE	∅ perçage	Dimensions	Réf.	Prix unitaire TARIF H.T.
3/32	1.8	3/32x48x40	B707 W006	29.22 €
1/8	2.5	1/8x40x36	B707 W008	21.20 €
5/32	3.1	5/32x32x48	B707 W010	23.89 €
3/16	3.6	3/16x24x52	B707 W012	22.05 €
7/32	4.4	7/32x24x56	B707 W014	27.31 €
1/4	5.1	1/4x20x56	B707 W016	19.69 €
5/16	6.5	5/16x18x63	B707 W020	23.50 €
3/8	7.9	3/8x16x70	B707 W024	33.48 €
7/16	9.3	7/16x14x70	B707 W028	45.22 €
1/2	10.5	1/2x12x80	B707 W032	51.79 €
9/16	12	9/16x12x80	B707 W036	74.30 €
5/8	13.5	5/8x11x90	B707 W040	72.93 €
3/4	16.5	3/4x10x105	B707 W048	103.52 €
7/8	19.25	7/8x9x110	B707 W056	189.55 €
1	22	1"x8x110	B707 W064	236.80 €
1*1/8	24.75	1"1/8x7x125	B707 W072	331.33 €
1*1/4	27.75	1"1/4x7x125	B707 W080	383.32 €
1*3/8	30.5	1"3/8x6x150	B707 W088	538.87 €
1*1/2	33.5	1"1/2x6x150	B707 W096	624.65 €
1*5/8	35.5	1"5/8x5x150	B707 W104	740.63 €
1*3/4	39	1"3/4x5x160	B707 W112	856.75 €
1*7/8	41.5	1"7/8x4.5x180	B707 W120	1 000.04 €
2	44.5	2"x4.5x180	B707 W128	1 143.24 €

Ces tarauds sont livrés par série de 3 : ébauche, intermédiaire et finition. Seul le taraud lisse de finition de la série possède les dimensions finales du filet à obtenir.

ébauche



finition



réf. B720

TAILLE	∅ perçage	Dimensions	Réf.	Prix unitaire TARIF H.T.
1/16	6.8	1/16x28x56	B720 G004	28.62 €
1/8	8.8	1/8x28x63	B720 G008	22.05 €
1/4	11.8	1/4x19x70	B720 G016	27.56 €
3/8	15.25	3/8x19x70	B720 G024	39.79 €
1/2	19	1/2x14x80	B720 G032	65.85 €
3/4	24.5	3/4x14x90	B720 G048	99.96 €
1	30.75	1x11x100	B720 G064	191.27 €
1 1/4	39.5	1"1/4x11x125	B720 G080	339.93 €
1 1/2	45.2	1"1/2x11x125	B720 G096	430.44 €

Ces tarauds sont livrés par série de 2 : ébauche, et finition.
Seul le taraud lisse de finition de la série possède les dimensions
finales du filet à obtenir.



réf. B215

conditions de coupe recommandées p. 65

TAILLE	Ø perçage	Dimensions	Réf.	Prix unitaire TARIF H.T.
DIN 371				
No.4	2.3	No.4x40x2Bx56	B215 C004	16.20 €
No.5	2.6	No.5x40x2Bx56	B215 C005	12.80 €
No.6	2.85	No.6x32x2Bx56	B215 C006	14.50 €
No.8	3.5	No.8x32x2Bx63	B215 C008	12.80 €
No.10	3.9	No.10x24x2Bx70	B215 C010	13.26 €
No.12	4.5	No.12x24x2Bx80	B215 C012	13.26 €
1/4	5.2	1/4x20x2Bx80	B215 C016	13.26 €
5/16	6.6	5/16x18x2Bx90	B215 C020	17.13 €
3/8	8	3/8x16x2Bx100	B215 C024	20.60 €
DIN 376				
7/16	9.4	7/16x14x2Bx110	B215 C028	27.77 €
1/2	10.75	1/2x13x2Bx110	B215 C032	27.77 €
9/16	12.25	9/16x12x2Bx110	B215 C036	33.60 €
5/8	13.5	5/8x11x2Bx110	B215 C040	42.20 €
3/4	16.5	3/4x10x2Bx125	B215 C048	65.77 €
7/8	19.5	7/8x9x2Bx140	B215 C056	81.51 €
1"	22.25	1"x8x2Bx160	B215 C064	113.81 €
1" 1/8-7	25	1"x1/8x 7x180	B215 C072	163.44 €



réf. B419

conditions de coupe recommandées p. 65

TAILLE	∅ perçage	Dimensions	Réf.	Prix unitaire TARIF H.T.
DIN 371				
No.4	2.3	No.4x40x2Bx56	B419 C004	16.34 €
No.5	2.6	No.5x40x2Bx56	B419 C005	13.00 €
No.6	2.85	No.6x32x2Bx56	B419 C006	13.00 €
No.8	3.5	No.8x32x2Bx63	B419 C008	13.00 €
No.10	3.9	No.10x24x2Bx70	B419 C010	13.51 €
No.12	4.5	No.12x24x2Bx80	B419 C012	13.51 €
1/4	5.2	1/4x20x2Bx80	B419 C016	13.51 €
5/16	6.6	5/16x18x2Bx100	B419 C020	17.53 €
3/8	8	3/8x16x2Bx100	B419 C024	21.00 €
DIN 376				
7/16	9.4	7/16x14x2Bx100	B419 C028	28.36 €
1/2	10.75	1/2x13x2Bx110	B419 C032	28.36 €
9/16	12.25	9/16x12x2Bx110	B419 C036	38.00 €
5/8	13.5	5/8x11x2Bx110	B419 C040	42.99 €
3/4	16.5	3/4x10x2Bx125	B419 C048	75.67 €
7/8	19.5	7/8x9x2Bx140	B419 C056	93.86 €
1	22.25	1"x8x2Bx160	B419 C064	124.46 €
1"1/8	25	1" 1/8x7x2Bx180	B419 C072	178.78 €



réf. B218

conditions de coupe recommandées p. 65

TAILLE	∅ perçage	Dimensions	Réf.	Prix unitaire TARIF H.T.
DIN 371				
No.4	2.4	No.4x48x2Bx56	B218 F004	31.70 €
No.5	2.7	No.5x44x2Bx56	B218 F005	25.33 €
No.6	3	No.6x40x2Bx56	B218 F006	25.33 €
No.8	3.5	No.8x36x2Bx63	B218 F008	25.33 €
No.10	4.1	No.10x32x2Bx70	B218 F010	25.81 €
No.12	4.7	No.12x28x2Bx80	B218 F012	25.33 €
1/4	5.5	1/4x28x2Bx80	B218 F016	25.33 €
5/16	6.9	5/16x24x2Bx90	B218 F020	27.70 €
3/8	8.5	3/8x24x2Bx100	B218 F024	32.44 €
DIN 374				
7/16	9.9	7/16x20x2Bx100	B218 F028	39.45 €
1/2	11.5	1/2x20x2Bx100	B218 F032	39.45 €
9/16-18	12.9	9/16x18x100	B218 F036	44.30 €
5/8	14.5	5/8x18x2Bx100	B218 F040	56.39 €
3/4	17.9	3/4x16x2Bx110	B218 F048	81.15 €
7/8	20.5	7/8x14x2Bx125	B218 F056	93.66 €
1"	23.25	1"x12x150	B218 F064	120.18 €
1"1/8	26.5	1"1/8x12x150	B218 F072	143.62 €



réf. B423

conditions de coupe recommandées p. 65

TAILLE	∅ perçage	Dimensions	Réf.	Prix unitaire TARIF H.T.
DIN 371				
No.4	2.4	No.4x48x2Bx56	B423 F004	33.29 €
No.5	2.7	No.5x44x2Bx56	B423 F005	26.59 €
No.6	3	No.6x40x2Bx56	B423 F006	26.59 €
No.8	3.5	No.8x36x2Bx63	B423 F008	26.59 €
No.10	4.1	No.10x32x2Bx70	B423 F010	27.06 €
No.12	4.7	No.12x28x2Bx80	B423 F012	26.59 €
1/4	5.5	1/4x28x2Bx80	B423 F016	26.59 €
5/16	6.9	5/16x24x2Bx90	B423 F020	29.08 €
3/8	8.5	3/8x24x2Bx100	B423 F024	34.07 €
DIN 374				
7/16	9.9	7/16x20x2Bx100	B423 F028	41.40 €
1/2	11.5	1/2x20x2Bx100	B423 F032	41.40 €
9/16	12.9	9/16x18x2Bx100	B423 F036	46.54 €
5/8	14.5	5/8x18x2Bx100	B423 F040	59.19 €
3/4	17.9	3/4x16x2Bx110	B423 F048	85.18 €
7/8	20.5	7/8x14x2Bx125	B423 F056	98.33 €
1	23.25	1"x12x2Bx140	B423 F064	126.28 €
1"1/8	26.5	1"1/8x12x2Bx150	B423 F072	150.76 €



DIN 2182



DIN 2183



réf. B221

conditions de coupe recommandées p. 65

TAILLE	∅ perçage	Dimensions	Réf.	Prix unitaire TARIF H.T.
DIN 2182				
1/8	2.5	1/8x40x56	B221 W008	12.80 €
5/32	3.1	5/32x32x63	B221 W010	12.80 €
3/16	3.6	3/16x24x70	B221 W012	13.26 €
7/32	4.4	7/32x24x80	B221 W014	13.26 €
1/4	5.1	1/4x20x80	B221 W016	13.26 €
5/16	6.5	5/16x18x90	B221 W020	17.13 €
3/8	7.9	3/8x16x100	B221 W024	20.60 €
DIN 2183				
7/16	9.3	7/16x14x100	B221 W028	27.77 €
1/2	10.5	1/2x12x110	B221 W032	27.77 €
9/16	12	9/16x12x110	B221 W036	33.60 €
5/8	13.5	5/8x11x110	B221 W040	42.20 €
3/4	16.5	3/4x10x125	B221 W048	65.77 €
7/8	19.25	7/8x9x140	B221 W056	81.51 €
1"	22	1"x8x160	B221 W064	113.81 €
1"1/8	24.75	1" 1/8x7x180	B221 W072	159.23 €



DIN 2182



DIN 2183



réf. B427

conditions de coupe recommandées p. 65

TAILLE	∅ perçage	Dimensions	Réf.	Prix unitaire TARIF H.T.
DIN 2182				
1/8	2.5	1/8x40x56	B427 W008	13.00 €
5/32	3.1	5/32x32x63	B427 W010	13.00 €
3/16	3.6	3/16x24x70	B427 W012	13.51 €
7/32	4.4	7/32x24x80	B427 W014	13.51 €
1/4	5.1	1/4x20x80	B427 W016	13.51 €
5/16	6.5	5/16x18x90	B427 W020	17.53 €
3/8	7.9	3/8x16x100	B427 W024	21.00 €
DIN 2183				
7/16	9.3	7/16x14x100	B427 W028	28.36 €
1/2	10.5	1/2x12x110	B427 W032	28.36 €
9/16	12	9/16x12x110	B427 W036	38.00 €
5/8	13.5	5/8x11x110	B427 W040	42.99 €
3/4	16.5	3/4x10x125	B427 W048	75.67 €
7/8	19.25	7/8x9x140	B427 W056	93.86 €
1	22	1"x8x160	B427 W064	119.06 €
1"1/8	24.75	1" 1/8x7x180	B427 W072	166.59 €



DIN 5156



réf. B721

conditions de coupe recommandées p. 65

TAILLE	∅ perçage	Dimensions	Réf.	Prix unitaire TARIF H.T.
1/8	8.8	1/8x28x90	B721 G008	26.18 €
1/4	11.8	1/4x19x100	B721 G016	34.52 €
3/8	15.25	3/8x19x100	B721 G024	40.15 €
1/2	19	1/2x14x125	B721 G032	58.35 €
3/4	24.5	3/4x14x140	B721 G048	106.07 €
1	30.75	1x11x160	B721 G064	155.69 €



DIN 5156



réf. B722

conditions de coupe recommandées p. 65

TAILLE	∅ perçage	Dimensions	Réf.	Prix unitaire TARIF H.T.
1/8	8.8	1/8x28x90	B722 G008	26.72 €
1/4	11.8	1/4x19x100	B722 G016	35.45 €
3/8	15.25	3/8x19x100	B722 G024	40.15 €
1/2	19	1/2x14x125	B722 G032	58.09 €
3/4	24.5	3/4x14x140	B722 G048	109.16 €
1"	30.75	1"x11x160	B722 G064	159.82 €

TARAUD HSS-E DROIT ACIER 80 KG DIN 371



réf. B201

conditions de coupe recommandées p.66

TAILLE	∅ perçage	Dimensions	Réf.	Prix unitaire TARIF H.T.
M2	1.6	M2x0.4x6Hx45	B201 M020	16.87 €
M2.2	1.75	M2.2x0.45x6Hx45	B201 M022	18.91 €
M2.3	1.9	M2.3x0.4x6Hx45	B201 M023	21.20 €
M2.5	2.05	M2.5x0.45x6Hx50	B201 M025	14.11 €
M2.6	2.1	M2.6x0.45x6Hx50	B201 M026	13.39 €
M3	2.5	M3x0.5x6Hx56	B201 M030	11.09 €
M3.5	2.9	M3.5x0.6x6Hx56	B201 M035	12.60 €
M4	3.3	M4x0.7x6Hx63	B201 M040	11.09 €
M4.5	3.7	M4.5x0.75x6Hx70	B201 M045	11.49 €
M5	4.2	M5x0.8x6Hx70	B201 M050	11.49 €
M6	5	M6x1.0x6Hx80	B201 M060	11.49 €
M7	6	M7x1.0x6Hx80	B201 M070	13.46 €
M8	6.8	M8x1.25x6Hx90	B201 M080	14.90 €
M9	7.8	M9x1.25x6Hx90	B201 M090	17.92 €
M10	8.5	M10x1.5x6Hx100	B201 M100	17.92 €
M11	9.5	M11x1.5x6Hx100	B201 M110	19.89 €
M12	10.2	M12x1.75x6Hx110	B201 M120	19.89 €



DIN 371



DIN 376



réf. B403

conditions de coupe recommandées p.66

TAILLE	∅ perçage	Dimensions	Réf.	Prix unitaire TARIF H.T.
DIN 371				
M2	1.6	M2x0.4x6Hx45	B403 M020	16.81 €
M2.2	1.75	M2.2x0.45x6Hx45	B403 M022	18.85 €
M2.3	1.9	M2.3x0.4x6Hx45	B403 M023	21.06 €
M2.5	2.05	M2.5x0.45x6Hx50	B403 M025	13.92 €
M2.6	2.1	M2.6x0.45x6Hx50	B403 M026	13.39 €
M3	2.5	M3x0.5x6Hx56	B403 M030	11.09 €
M3.5	2.9	M3.5x0.6x6Hx56	B403 M035	12.54 €
M4	3.3	M4x0.7x6Hx63	B403 M040	11.09 €
M4.5	3.7	M4.5x0.75x6Hx70	B403 M045	11.49 €
M5	4.2	M5x0.8x6Hx70	B403 M050	11.49 €
M6	5	M6x1.0x6Hx80	B403 M060	11.49 €
M7	6	M7x1.0x6Hx80	B403 M070	14.90 €
M8	6.8	M8x1.25x6Hx90	B403 M080	14.90 €
M9	7.8	M9x1.25x6Hx90	B403 M090	17.92 €
M10	8.5	M10x1.5x6Hx100	B403 M100	17.92 €
DIN 376				
M11	9.5	M11x1.5x6Hx100	B403 M110	24.17 €
M12	10.2	M12x1.75x6Hx110	B403 M120	24.17 €
M14	12	M14x2.0x6Hx110	B403 M140	29.22 €
M16	14	M16x2.0x6Hx110	B403 M160	36.76 €
M18	15.5	M18x2.5x6Hx125	B403 M180	48.51 €
M20	17.5	M20x2.5x6Hx140	B403 M200	57.89 €
M22	19.5	M22x2.5x6Hx140	B403 M220	71.82 €
M24	21	M24x3.0x6Hx160	B403 M240	78.16 €
M27	24	M27x3.0x6Hx160	B403 M270	112.38 €
M30	26.5	M30x3.5x6Hx180	B403 M300	143.62 €

Ces tarauds sont livrés par série de 3 : ébauche, intermédiaire et finition. Seul le taraud lisse de finition de la série possède les dimensions finales du filet à obtenir.

TARAUD HSS-E DROIT ACIER 80 KG DIN 376



réf. B202

conditions de coupe recommandées p.66

TAILLE	∅ perçage	Dimensions	Réf.	Prix unitaire TARIF H.T.
M3	2.5	M3x0.5x6Hx56	B202 M030	13.79 €
M3.5	2.9	M3.5x0.6x6Hx56	B202 M035	15.50 €
M4	3.3	M4x0.7x6Hx63	B202 M040	13.79 €
M4.5	3.7	M4.5x0.75x6Hx70	B202 M045	14.38 €
M5	4.2	M5x0.8x6Hx70	B202 M050	14.38 €
M6	5	M6x1.0x6Hx80	B202 M060	14.38 €
M7	6	M7x1.0x6H	B202 M070	16.54 €
M8	6.8	M8x1.25x6Hx90	B202 M080	17.73 €
M9	7.8	M9x1.25x6Hx90	B202 M090	21.40 €
M10	8.5	M10x1.50x6Hx100	B202 M100	21.40 €
M11	9.5	M11x1.5x6Hx100	B202 M110	19.89 €
M12	10.2	M12x1.75x6Hx110	B202 M120	24.17 €
M14	12	M14x2.0x6Hx110	B202 M140	29.22 €
M16	14	M16x2.0x6Hx110	B202 M160	36.76 €
M18	15.5	M18x2.5x6Hx125	B202 M180	48.12 €
M20	17.5	M20x2.5x6Hx140	B202 M200	57.23 €
M22	19.5	M22x2.5x6Hx140	B202 M220	73.65 €
M24	21	M24x3.0x6Hx160	B202 M240	77.64 €
M27	24	M27x3.00x6Hx160	B202 M270	124.11 €
M30	26.5	M30x3.50x6Hx180	B202 M300	150.17 €



réf. B213

conditions de coupe recommandées p.66

TAILLE	∅ perçage	Dimensions	Réf.	Prix unitaire TARIF H.T.
M4	3.5	M4x0.5x6Hx63	B213 M040 050	19.15 €
M5	4.5	M5x0.5x6Hx70	B213 M050 050	19.49 €
M6	5.5	M6x0.5x6Hx80	B213 M060 050	19.49 €
M6	5.2	M6x0.75x6Hx80	B213 M060 075	19.15 €
M7	6.2	M7x0.75x6Hx80	B213 M070 075	28.42 €
M8	7.5	M8x0.5x6Hx80	B213 M080 050	25.87 €
M8	7.2	M8x0.75x6Hx80	B213 M080 075	22.26 €
M8	7	M8x1.0x6Hx90	B213 M080 100	20.94 €
M10	9.2	M10x0.75x6Hx90	B213 M100 075	30.93 €
M10	9	M10x1.0x6Hx90	B213 M100 100	24.54 €
M10	8.8	M10x1.25x6Hx100	B213 M100 125	25.41 €
M12	11	M12x1.0x6Hx100	B213 M120 100	28.42 €
M12	10.8	M12x1.25x6Hx100	B213 M120 125	29.86 €
M12	10.5	M12x1.5x6Hx100	B213 M120 150	27.36 €
M14	13	M14x1.0x6Hx100	B213 M140 100	35.17 €
M14	12.8	M14x1.25x6Hx100	B213 M140 125	36.23 €
M14	12.5	M14x1.5x6Hx100	B213 M140 150	33.48 €
M16	15	M16x1.0x6Hx100	B213 M160 100	46.20 €
M16	14.5	M16x1.5x6Hx100	B213 M160 150	42.67 €
M18	17	M18x1.0x6Hx110	B213 M180 100	60.84 €
M18	16.5	M18x1.5x6Hx110	B213 M180 150	55.40 €
M20	19	M20x1.0x6Hx125	B213 M200 100	66.03 €
M20	18.5	M20x1.5x6Hx125	B213 M200 150	61.37 €
M22	21	M22x1.0x6Hx125	B213 M220 100	88.55 €
M22	20.5	M22x1.5x6Hx125	B213 M220 150	70.75 €
M24	22.5	M24x1.5x6Hx140	B213 M240 150	82.64 €
M24	22	M24x2.0x6Hx140	B213 M240 200	86.98 €
M26	24.5	M26x1.5x6Hx140	B213 M260 150	106.07 €
M27	25.5	M27x1.5x6Hx140	B213 M270 150	117.74 €
M27	25	M27x2.00x6Hx140	B213 M270 200	118.68 €
M28	26.5	M28x1.5x6Hx140	B213 M280 150	120.18 €
M30	28.5	M30x1.5x6Hx150	B213 M300 150	135.55 €
M30	28	M30x2.00x6Hx150	B213 M300 200	139.62 €

TARAUD HSS-E HÉLICOÏDAL ACIER 80 KG MÉTRIQUE PAS FIN



réf. B415

conditions de coupe recommandées p.66

TAILLE	∅ perçage	Dimensions	Réf.	Prix unitaire TARIF H.T.
M4	3.5	M4x0.5x6Hx63	B415 M040 050	19.44 €
M5	4.5	M5x0.5x6Hx70	B415 M050 050	19.89 €
M6	5.2	M6x0.75x6Hx80	B415 M060 075	19.64 €
M6	5.5	M6x0.5x6Hx80	B415 M060 050	19.89 €
M7	6.2	M7x0.75x6Hx80	B415 M070 075	28.95 €
M8	7.0	M8x1.0x6Hx90	B415 M080 100	21.53 €
M8	7.2	M8x0.75x6Hx80	B415 M080 075	22.66 €
M8	7.5	M8x0.5x6Hx80	B415 M080 050	26.26 €
M10	8.8	M10x1.25x6Hx100	B415 M100 125	26.18 €
M10	9	M10x1.0x6Hx90	B415 M100 100	25.20 €
M10	9.2	M10x0.75x6Hx90	B415 M100 075	31.83 €
M12	10.5	M12x1.5x6Hx100	B415 M120 150	27.90 €
M12	10.8	M12x1.25x6Hx100	B415 M120 125	30.47 €
M12	11	M12x1.0x6Hx100	B415 M120 100	29.22 €
M14	12.5	M14x1.5x6Hx100	B415 M140 150	34.46 €
M14	12.8	M14x1.25x6Hx100	B415 M140 125	37.28 €
M14	13	M14x1.0x6Hx100	B415 M140 100	36.18 €
M16	14.5	M16x1.5x6Hx100	B415 M160 150	43.98 €
M16	15	M16x1.0x6Hx100	B415 M160 100	47.58 €
M18	16.5	M18x1.5x6Hx110	B415 M180 150	56.77 €
M18	17	M18x1.0x6Hx110	B415 M180 100	62.41 €
M20	18.5	M20x1.5x6Hx125	B415 M200 150	63.66 €
M20	19	M20x1.0x6Hx125	B415 M200 100	68.59 €
M22	20.5	M22x1.5x6Hx125	B415 M220 150	72.48 €
M22	21	M22x1.0x6Hx125	B415 M220 100	90.64 €
M24	22	M24x2.0x6Hx140	B415 M240 200	91.31 €
M24	22.5	M24x1.5x6Hx140	B415 M240 150	84.28 €
M26	24.5	M26x1.5x6Hx140	B415 M260 150	111.38 €
M27	25	M27x2.0x6Hx140	B415 M270 200	124.64 €
M27	25.5	M27x1.5x6Hx140	B415 M270 150	123.67 €
M28	26.5	M28x1.5x6Hx140	B415 M280 150	126.23 €
M30	28	M30x2.0x6Hx150	B415 M300 200	146.58 €
M30	28.5	M30x1.5x6Hx150	B415 M300 150	142.35 €



réf. B206

conditions de coupe recommandées p.66

TAILLE	∅ perçage	Dimensions	Réf.	Prix unitaire TARIF H.T.
DIN 371				
M2.0	1.6	M2.0x0.4x6Hx45	B206 M020 F	26.40 €
M2.5	2.05	M2.5x0.45x6H	B206 M025 F	24.42 €
M3	2.5	M3x0.5x6Hx56	B206 M030 F	21.13 €
M3.5	2.9	M3.5x0.6x6Hx56	B206 M035 F	21.53 €
M4	3.3	M4x0.7x6Hx63	B206 M040 F	21.13 €
M5	4.2	M5x0.8x6Hx70	B206 M050 F	21.59 €
M6	5	M6x1.0x6Hx80	B206 M060 F	21.40 €
M8	6.8	M8x1.25x6Hx90	B206 M080 F	30.38 €
M10	8.5	M10x1.5x6Hx100	B206 M100 F	35.57 €
DIN 376				
M12	10.2	M12x1.75x6Hx110	B206 M120 F	44.30 €
M14	12	M14x2.0x6Hx110	B206 M140 F	54.02 €
M16	14	M16x2.0x6Hx110	B206 M160 F	60.38 €
M18	15.5	M18x2.5x6Hx125	B206 M180 F	85.98 €
M20	17.5	M20x2.5x6Hx140	B206 M200 F	107.25 €
M22	19.5	M22x2.5x6Hx140	B206 M220 F	130.95 €
M24	21	M24x3.0x6Hx160	B206 M240 F	147.87 €
M27	24	M27x3.0x6Hx160	B206 M270 F	198.29 €
M30	26.5	M30x3.5x6Hx180	B206 M300 F	249.80 €

TARAUD HSS-E HÉLICOÏDAL ACIER 120 KG DIN 371/376 REVÊTU TiAIN



réf. B408

conditions de coupe recommandées p.66

TAILLE	∅ perçage	Dimensions	Réf.	Prix unitaire TARIF H.T.
DIN 371				
M2	1.6	M2x0.4x6Hx45.00	B408 M020 F	26.51 €
M2.5	2.05	M2.5x0.45x6Hx50.00	B408 M025 F	23.24 €
M3.0	2.5	M3.0x0.50x6Hx56.00	B408 M030 F	19.89 €
M3.5	2.9	M3.5x0.60x6Hx56.00	B408 M035 F	21.59 €
M4.0	3.3	M4.0x0.70x6Hx63.00	B408 M040 F	19.89 €
M5.0	4.2	M5.0x0.80x6Hx70.00	B408 M050 F	20.48 €
M6.0	5	M6.0x1.00x6Hx80.00	B408 M060 F	21.53 €
M8.0	6.8	M8.0x1.25x6Hx90.00	B408 M080 F	30.38 €
M10.0	8.5	M10.0x1.50x6Hx100.00	B408 M100 F	35.72 €
DIN 376				
M12.0	10.2	M12.0x1.75x6Hx110.00	B408 M120 F	44.24 €
M14.0	12	M14.0x2.00x6Hx110.00	B408 M140 F	51.19 €
M16.0	14	M16.0x2.00x6Hx110.00	B408 M160 F	60.64 €
M18.0	15.5	M18.0x2.50x6Hx125	B408 M180 F	81.85 €
M20	17.5	M20x2.5x6Hx140	B408 M200 F	107.70 €
M22	19.5	M22x2.5x6Hx140	B408 M220 F	124.24 €
M24	21	M24x3x6Hx160	B408 M240 F	148.54 €
M27	24	M27x3x6Hx160	B408 M270 F	200.07 €
M30	26.5	M30x3.5x6Hx180	B408 M300 F	250.99 €



réf. B207

conditions de coupe recommandées p.66

TAILLE	∅ perçage	Dimensions	Réf.	Prix unitaire TARIF H.T.
DIN 371				
M2	1.6	M2x0.4x6HXx45	B207 M020 V	19.55 €
M2.5	2.05	M2.5x0.45x6HXx50	B207 M025 V	16.20 €
M3	2.5	M3x0.5x6HXx56	B207 M030 V	12.80 €
M3.5	2.9	M3.5x0.6x6HXx56	B207 M035 V	14.50 €
M4	3.3	M4x0.7x6HXx63	B207 M040 V	12.80 €
M5	4.2	M5x0.8x6HXx70	B207 M050 V	13.39 €
M6	5	M6x1.0x6HXx80	B207 M060 V	13.39 €
M8	6.8	M8x1.25x6HXx90	B207 M080 V	17.13 €
M10	8.5	M10x1.5x6HXx100	B207 M100 V	20.75 €
DIN 376				
M12	10.2	M12x1.75x6HXx110	B207 M120 V	27.56 €
M14	12	M14x2.0x6HXx110	B207 M140 V	33.54 €
M16	14	M16x2.0x6HXx110	B207 M160 V	42.20 €
M18	15.5	M18x2.5x6HXx125	B207 M180 V	55.21 €
M20	17.5	M20x2.5x6HXx140	B207 M200 V	65.85 €
M22	19.5	M22x2.5x6HXx140	B207 M220 V	81.60 €
M24	21	M24x3.0x6HXx160	B207 M240 V	88.81 €
M27	24	M27x3.0x6HXx160	B207 M270 V	127.74 €
M30	26.5	M30x3.5x6HXx180	B207 M300 V	163.24 €

TARAUD HSS-E HÉLICOÏDAL INOX DIN 371/376 TRAITÉ VAP

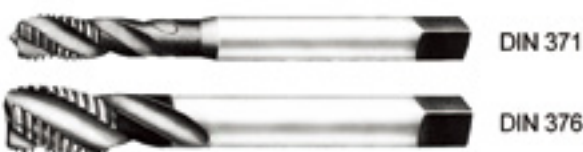

réf. B409

conditions de coupe recommandées p. 66

TAILLE	∅ perçage	Dimensions	Réf.	Prix unitaire TARIF H.T.
DIN 371				
M2	1.6	M2x0.4x6Hx45	B409 M020 V	21.85 €
M2.5	2.05	M2.5x0.45x6Hx50	B409 M025 V	18.11 €
M3	2.5	M3x0.5x6Hx56	B409 M030 V	14.50 €
M3.5	2.9	M3.5x0.6x6Hx56	B409 M035 V	16.34 €
M4	3.3	M4x0.7x6Hx63	B409 M040 V	14.64 €
M5	4.2	M5x0.8x6Hx70	B409 M050 V	15.11 €
M6	5	M6x1.0x6Hx80	B409 M060 V	15.11 €
M8	6.8	M8x1.25x6Hx90	B409 M080 V	19.15 €
M10	8.5	M10x1.5x6Hx100	B409 M100 V	23.16 €
DIN 376				
M12	10.2	M12x1.75x6Hx110	B409 M120 V	30.53 €
M14	12	M14x2.0x6Hx110	B409 M140 V	36.57 €
M16	14	M16x2.0x6Hx110	B409 M160 V	45.88 €
M18	15.5	M18x2.5x6Hx125	B409 M180 V	60.64 €
M20	17.5	M20x2.5x6Hx140	B409 M200 V	72.39 €
M22	19.5	M22x2.5x6Hx140	B409 M220 V	89.71 €
M24	21	M24x3.0x6Hx160	B409 M240 V	97.73 €
M27	24	M27x3.0x6Hx160	B409 M270 V	140.39 €
M30	26.5	M30x3.5x6Hx180	B409 M300 V	179.44 €

FILIÈRE HSS AVEC CAGE EXTENSIBLE

réf. FM

Ø de vis	Ø du Pilote	Réf.	Prix unitaire TARIF H.T.
Cage 25.4			
M2	2x0,4	FM020 004254	10.97 €
M3	3x0,5	FM030 005254	10.97 €
M4	4x0,7	FM040 007254	10.97 €
M5	5x0,8	FM050 080254	10.97 €
M6	6x1	FM060 100254	10.97 €
M8	8x1,25	FM080 125254	10.97 €
M10	10x1,50	FM100 150254	10.97 €
M12	12x1,75	FM120 175254	10.97 €
Cage 38.1			
M12	12x1,75	FM120 175381	26.33 €
M14	14x2	FM140 200381	26.33 €
M16	16x2	FM160 200381	26.33 €
M18	18x2,5	FM180 250381	26.33 €
M20	20x2,5	FM200 250381	26.33 €

TOURNE À GAUCHE HSS EXTENSIBLE

réf. FT200

Dimensions	Réf.	Prix unitaire TARIF H.T.
Capacité 1 à 8- n°0	FT200 05003	16.56 €
Capacité 1 à 10- n°1	FT200 05004	24.72 €
Capacité 4 à 12 - n°2	FT200 05005	45.62 €
Capacité 5 à 20- n°3	FT200 05006	72.62 €
Capacité 11 à 27- n°4	FT200 05007	101.09 €

PORTE-FILIÈRES HSS À 2 BRANCHES

réf. FP200

Dimensions	Réf.	Prix unitaire TARIF H.T.
C20,6 - n°0	FP200 03002	21.57 €
C25,4 - n°1	FP200 03003	20.56 €
C38,1 - n°2	FP200 03004	32.96 €
C50,8 - n°3	FP200 03005	66.93 €
C63,5 - n°4	FP200 03006	114.33 €

VITESSE DE ROTATION (tr/min)

Ø d'outil	Vitesse de coupe (m/min)															
	1	2	3	4	5	6	8	10	12	15	20	25	30	40	50	60
1	318	637	955	1274	1592	1910	2548	3185	3822	4777	6396	7962	9554	12739	15924	19108
2	159	318	478	637	796	955	1274	1592	1911	2388	3185	3981	4777	6369	7962	9554
3	106	212	318	425	531	637	849	1062	1274	1592	2123	2654	3185	4246	5308	6309
4	80	159	239	318	398	478	637	796	955	1194	1592	1990	2389	3185	3981	4777
5	64	127	191	255	318	382	510	637	764	955	1274	1592	1911	2548	3185	3822
6	53	106	159	212	265	318	425	531	637	796	1062	1327	1592	2123	2653	3185
8	40	80	119	159	199	239	318	398	478	597	796	955	1194	1592	1990	2388
10	31	64	96	127	159	191	255	318	382	478	637	796	955	1274	1592	1911
12	26	53	80	106	133	159	212	265	318	398	531	663	796	1082	1327	1592
14	23	45	68	91	114	136	182	227	273	341	455	569	682	910	1137	1365
16	20	40	60	80	100	119	159	199	239	299	398	498	597	796	995	1194
18	18	35	53	71	88	106	142	177	212	265	354	442	531	708	885	1062
20	16	32	48	64	80	96	127	159	191	239	318	398	478	637	796	955
25	13	25	38	51	64	76	102	127	153	191	255	318	382	510	637	764
30	11	21	32	42	53	64	85	106	127	159	212	265	318	425	531	637
25	9	18	27	36	45	55	73	91	109	136	182	227	273	364	455	546
40	8	16	24	32	40	48	64	80	96	119	159	199	239	318	398	478

RPM = tr/min

V = m/min

D = Dia.(mm)

$$V = \frac{RPM \cdot \pi \cdot D}{1000}$$

$$RPM = \frac{1000 \cdot V}{\pi \cdot D}$$

TARAUDS GAZ

ref. B215, B419, B218, B423, B221, B427, B721, B722

MATIERES		RESISTANCE A LA TRACTION	N/mm ²	VITESSE DE COUPE	M/min	LUBRIFIANT
ACIERS			<400		20 à 25	Emulsion d'huile
			<700		15 à 20	
			<850		12 à 18	
FONTES MALLÉABLES			<700		10 à 15	Huile de coupe
			<1000		5 à 8	
CUIVRE - BRONZE			<700		15 à 20	Emulsion d'huile
ALUMINIUMS	< 0.5%		<500		25 à 35	Emulsion d'huile
	< 10 %		<400		15 à 20	
	> 10%		<400		10 à 15	

TARAUDS MÉTRIQUES ACIERS

ref. B201, B403, B202, B213, B415

MATERES			N/mm ²		M/min		
ACIERS		RESISTANCE A LA TRACTION	<700	VITESSE DE COUPE	15 à 20	Emulsion d'huile	
			<850		12 à 18		
			<850		10 à 15		Emulsion d'huile ou huile de coupe
			<700		10 à 15		Emulsion d'huile ou huile de coupe
FONTES MALLÉABLES			<1000		5 à 8		
CUIVRE COPEAUX LONGS			<700		15 à 20	Emulsion d'huile ou huile de coupe	
ALUMINIUMS	< 350		<350		10 à 15	Emulsion d'huile ou huile de coupe	
	< 0.5%		<500		25 à 35		
	< 10 %		<400		15 à 20		
	> 10%		<400		10 à 15		

TARAUDS MÉTRIQUES ACIERS DURS

ref. B206, B408







MATERES			N/mm ²		M/min	
ACIERS		RESISTANCE A LA TRACTION	<1200	VITESSE DE COUPE	6 à 10	Emulsion d'huile
			>1200		3 à 5	
INOX			<1100		4 à 6	Huile de coupe
CUIVRE			<1500		3 à 5	Huile de coupe
PLASTIQUES					5 à 12	Sec ou Emulsion d'huile

TARAUDS INOX

ref. B207, B409

MATERES			N/mm ²		M/min	
ACIERS		RESISTANCE A LA TRACTION	<400	VITESSE DE COUPE	20 à 25	Emulsion d'huile
			<700		15 à 20	
INOX			<850		7 à 10	Huile de coupe
INOX AUSTENITIQUE			<850		5 à 8	Huile de coupe
INOX			<1100		4 à 6	Huile de coupe
TITANE ALLIÉ			<900		8 à 12	Huile de coupe
NICKEL ALLIÉ	< 350		<900		10 à 15	Huile de coupe

FRAISES CARBURE MATÉRIAUX DURS

			LISTE DES MATIÈRES							
			30HRC	aciers jusqu'à 55HRC	aciers jusqu'à 60HRC	aciers INOX	fontes	ALU	Titane	plastiques
C305	Fraises carbure 4 dents cylindriques courtes revêtues TiAlN		p.68	●	●	●	●			
C306	Fraises carbure 4 dents cylindriques longues revêtues TiAlN		p.69	●	●		●			
C307	Fraises carbure multidents 45° cylindriques longue revêtues TiAlN		p.69	●	●		●			
C308	Fraises carbure 6 dents 45° cylindriques extra longues revêtues TiAlN		p.70	●	●		●			
C310	Fraises carbure 2 dents hémisphériques cylindriques longues revêtues TiAlN		p.70	●	●		●			
C321	Fraises carbure 4 dents hémisphériques cylindriques longues revêtues TiAlN		p.71	●	●		●			

● utilisation conseillée pour la matière concernée.

DONNÉES TECHNIQUES

Conditions de coupe recommandées

pages 72 à 76

FRAISES CARBURE 4 DENTS CYLINDRIQUES COURTES RÉVÊTUES TiAIN



réf. C305

conditions de coupe recommandées p. 72

Ø fraissage	Dimensions	Réf.	Prix unitaire TARIF H.T.
2.0	2x4x6x40	C305 0200 X	31.50 €
2.5	2.5x6x8x40	C305 02501 X	45.48 €
3.0	3x6x8x45	C305 0300 X	45.48 €
3.5	3.5x6x10x45	C305 0350 X	45.48 €
4.0	4x6x11x45	C305 0400 X	45.48 €
4.5	4.5x6x11x45	C305 0450 X	45.48 €
5.0	5x6x13x50	C305 0500 X	45.48 €
5.5	5.5x6x13x50	C305 0550 X	45.48 €
6.0	6x6x13x50	C305 0600 X	45.48 €
6.5	6.5x8x16x60	C305 0650 X	58.26 €
7.0	7x8x16x60	C305 0700 X	58.26 €
7.5	7.5x8x16x60	C305 0750 X	58.26 €
8.0	8x8x19x60	C305 0800 X	58.26 €
8.5	8.5x10x19x70	C305 0850 X	86.23 €
9.0	9x10x19x70	C305 0900 X	86.23 €
9.5	9.5x10x19x70	C305 0950 X	86.23 €
10.0	10x10x22x70	C305 1000 X	86.23 €
10.5	10.5x12x22x75	C305 1050 X	118.22 €
11.0	11x12x22x75	C305 1100 X	118.22 €
11.5	11.5x12x22x75	C305 1150 X	118.22 €
12.0	12x12x26x75	C305 1200 X	118.22 €
13.0	13x12x26x85	C305 13001 X	149.98 €
14.0	14x14x26x85	C305 1400 X	149.98 €
15.0	15x16x26x90	C305 15001 X	196.13 €
16.0	16x16x32x100	C305 1600 X	196.13 €
17.0	17x16x32x100	C305 17001 X	260.65 €
18.0	18x18x32x100	C305 1800 X	260.65 €
19.0	19x20x32x100	C305 19001 X	325.20 €
20.0	20x20x38x105	C305 2000 X	325.20 €
22.0	22x20x38x105	C305 2200 X	422.78 €
24.0	24x25x45x120	C305 2400 X	520.28 €
25.0	25x25x45x120	C305 2500 X	520.28 €

tolérance fraises (mm)	tolérance Ø queue
0~-0.03	h6

FRAISES CARBURE 4 DENTS CYLINDRIQUES LONGUES REVÊTUES TiAIN



réf. C306

conditions de coupe recommandées p. 73

Ø fraissage	Dimensions	Réf.	Prix unitaire TARIF H.T.	Ø fraissage	Dimensions	Réf.	Prix unitaire TARIF H.T.
2.0	2x4x8x40	C306 0200 X	37.73 €	12.0	12x12x30x90	C306 1200 X	141.94 €
3.0	3x6x12x50	C306 0300 X	54.59 €	14.0	14x16x40x110	C306 1400 X	202.44 €
4.0	4x6x15x50	C306 0400 X	54.59 €	16.0	16x16x50x110	C306 1600 X	264.83 €
5.0	5x6x20x60	C306 0500 X	54.59 €	18.0	18x20x50x110	C306 1800 X	359.84 €
6.0	6x6x20x60	C306 0600 X	54.59 €	20.0	20x20x55x110	C306 2000 X	439.00 €
8.0	8x8x25x70	C306 0800 X	69.94 €	25.0	25x25x75x140	C306 2500 X	702.46 €
10.0	10x10x30x90	C306 1000 X	103.44 €				

tolérance fraises (mm)	tolérance Ø queue
0--0.03	h6

FRAISES CARBURE MULTIDENTS 45° CYLINDRIQUES LONGUES REVÊTUES TiAIN



réf. C307

conditions de coupe recommandées p. 74

Ø fraissage	Dimensions	Réf.	Prix unitaire TARIF H.T.	Ø fraissage	Dimensions	Réf.	Prix unitaire TARIF H.T.
6 dents				8 dents			
6.0	6x6x13x57	C307 0600 X	53.28 €	18.0	18x18x32x92	C307 1800 X	269.87 €
7.0	7x8x16x63	C307 0700 X	67.37 €	20.0	20x20x38x104	C307 2000 X	339.06 €
8.0	8x8x19x63	C307 0800 X	67.37 €	25.0	25x25x44x104	C307 2500 X	598.33 €
9.0	9x10x19x72	C307 0900 X	100.94 €				
10.0	10x10x22x72	C307 1000 X	100.94 €				
12.0	12x12x26x83	C307 1200 X	137.25 €				
14.0	14x16x26x83	C307 14001 X	230.76 €				
16.0	16x16x32x92	C307 1600 X	230.76 €				

tolérance fraises (mm)	tolérance Ø queue
0--0.03	h6

FRAISES CARBURE 6 DENTS 45° CYLINDRIQUES EXTRA LONGUES REVÊTUES TiAIN



réf. C308

conditions de coupe recommandées p. 73

Ø fraise	Dimensions	Réf.	Prix unitaire TARIF H.T.	Ø fraise	Dimensions	Réf.	Prix unitaire TARIF H.T.
6.0	6x6x26x70	C308 0600 X	69.25 €	16.0	16x16x66x130	C308 1600 X	346.24 €
8.0	8x8x36x90	C308 0800 X	91.03 €	20.0	20x20x76x140	C308 2000 X	542.56 €
10.0	10x10x46x100	C308 1000 X	141.55 €	25.0	25x25x92x180	C308 2500 X	1 017.17 €
12.0	12x12x56x110	C308 1200 X	199.00 €				

tolérance fraises (mm)	tolérance Ø queue
0--0.03	h6

FRAISES CARBURE 2 DENTS HÉMISPHERIQUES CYLINDRIQUES LONGUES REVÊTUES TiAIN



réf. C310

conditions de coupe recommandées p. 75

Ø fraise	Dimensions	Réf.	Prix unitaire TARIF H.T.	Ø fraise	Dimensions	Réf.	Prix unitaire TARIF H.T.
1.0	1x4x2.5x50	C310 0100 X	45.48 €	6.0	6x6x12x90	C310 0600 X	50.61 €
1.0	1x6x2.5x50	C310 01001 X	47.59 €	7.0	7x8x14x90	C310 0700 X	79.10 €
1.2	1.2x4x3x50	C310 0120 X	45.48 €	8.0	8x8x14x100	C310 0800 X	79.10 €
1.5	1.5x4x4x50	C310 0150 X	45.48 €	9.0	9x10x18x100	C310 0900 X	126.27 €
1.5	1.5x6x4x50	C310 01501 X	47.59 €	10.0	10x10x18x100	C310 1000 X	126.27 €
2.0	2x6x5x50	C310 0200 X	43.29 €	12.0	12x12x22x110	C310 1200 X	161.07 €
2.5	2.5x6x6x60	C310 0250 X	43.29 €	14.0	14x14x26x110	C310 1400 X	202.13 €
3.0	3x6x8x60	C310 0300 X	43.29 €	16.0	16x16x30x140	C310 1600 X	267.80 €
3.5	3.5x6x8x70	C310 0350 X	45.16 €	18.0	18x18x34x140	C310 1800 X	292.03 €
4.0	4x6x8x70	C310 0400 X	45.16 €	20.0	20x20x38x160	C310 2000 X	417.91 €
5.0	5x6x10x80	C310 0500 X	46.79 €	25.0	25x25x50x180	C310 2500 X	668.64 €

tolérance fraises (mm)	tolérance Ø queue
0--0.03	h6

FRAISES CARBURE 4 DENTS HÉMISPHERIQUES CYLINDRIQUES LONGUES REVÊTUES TiAlN



réf. C321

conditions de coupe recommandées p. 76

Ø fraise	Dimensions	Réf.	Prix unitaire TARIF H.T.
1	1x4x2.5x50	C321 0100 X	59.89 €
1	1x6x2.5x50	C321 01001 X	62.71 €
1.5	1.5x4x4x50	C321 0150 X	59.89 €
1.5	1.5x6x4x50	C321 01501 X	62.71 €
2	2x6x5x50	C321 0200 X	57.02 €
3	3x6x8x60	C321 0300 X	57.02 €
4	4x6x8x70	C321 0400 X	58.90 €
5	5x6x10x80	C321 0500 X	60.77 €
6	6x6x12x90	C321 0600 X	64.50 €
7	7x8x14x90	C321 0700 X	95.08 €

Ø fraise	Dimensions	Réf.	Prix unitaire TARIF H.T.
8	8x8x14x100	C321 0800 X	95.08 €
9	9x10x18x100	C321 0900 X	146.16 €
10	10x10x18x100	C321 1000 X	146.16 €
12	12x12x22x110	C321 1200 X	183.91 €
14	14x14x26x110	C321 1400 X	227.69 €
16	16x16x30x140	C321 1600 X	302.31 €
18	18x18x34x140	C321 1800 X	352.78 €
20	20x20x38x160	C321 2000 X	503.26 €
25	25x25x50x180	C321 2500 X	805.34 €

tolérance fraises (mm)	tolérance Ø queue
0~-0.03	h6

CARBURE, 4 DENTS SÉRIE COURTE - USINAGE LATÉRAL

réf. C305

Matière Usinée	Aciers non alliés Aciers alliés Fontes		Aciers alliés Aciers réfractaires		Aciers INOX		Aciers trempés	
DURETÉ	HRc 30		HRc 30 ~ HRc 45				HRc 45 ~ HRc 55	
RESISTANCE	~ 1000N/mm ²		1000 ~ 1500N/mm ²				1500 ~ 2000N/mm ²	
DIAMETRE	RPM	Avance	RPM	Avance	RPM	Avance	RPM	Avance
2.0	11 560	280	7 560	170	6 300	140	5 040	50
3.0	8 920	320	5 560	200	4 620	170	3 360	60
4.0	7 560	570	4 620	350	3 880	280	2 940	60
5.0	6 300	600	3 780	360	3 160	300	2 320	70
6.0	5 560	660	3 360	410	2 840	330	2 000	80
8.0	4 200	710	2 520	380	2 100	350	1 680	110
10.0	3 260	610	2 000	300	1 680	300	1 360	90
12.0	2 740	520	1 680	250	1 360	240	1 160	80
16.0	2 200	410	1 360	200	1 100	200	900	60
20.0	1 680	320	1 060	160	840	150	680	40
25.0	1 360	250	840	130	680	120	540	30



R.P.M. = tours/minute
Avance = mm/minute

CARBURE, 4 DENTS SÉRIE LONGUE - USINAGE LATÉRAL

réf. C306

Matière Usinée	Aciers non alliés Aciers alliés		Aciers alliés Aciers réfractaires		Aciers trempés	
DURETÉ	~ HRc30		HRc30 ~ HRc45		HRc45 ~ HRc55	
RESISTANCE	~ 1000N/mm ²		1000 ~ 1500N/mm ²		1500 ~ 2000N/mm ²	
DIAMETRE	RPM	Avance	RPM	Avance	RPM	Avance
2.0	8 820	200	5 040	80	3 150	45
3.0	6 170	230	3 570	100	2 200	55
4.0	5 000	280	2 840	115	1 790	60
5.0	4 270	360	2 420	140	1 580	70
6.0	3 680	430	2 100	180	1 370	90
8.0	2 800	460	1 580	180	1 050	90
10.0	2 350	460	1 370	180	840	90
12.0	1 920	360	1 160	160	700	70
16.0	1 620	320	890	125	560	60
20.0	1 180	230	680	90	420	45



R.P.M. = tours/minute
Avance = mm/minute

CARBURE, 6 DENTS HÉLICE 45° SÉRIE EXTRA LONGUE USINAGE LATÉRAL

réf. C308

Matière Usinée	Aciers non alliés Aciers alliés		Aciers alliés Aciers réfractaires		Aciers trempés		Aciers trempés	
DURETÉ	HRc 40		HRc 40 ~ HRc 50		HRc 50 ~ HRc 60		HRc60 ~ HRc65	
RESISTANCE	~ 1250N/mm ²		1250 ~ 1750N/mm ²		1750 ~ 2080N/mm ²		2080N/mm ² ~	
DIAMETRE	RPM	Avance	RPM	Avance	RPM	Avance	RPM	Avance
6.0	2 230	470	1 670	350	1 390	250	1 110	200
8.0	1 670	450	1 250	330	1 050	240	840	180
10.0	1 330	440	1 000	300	840	230	680	160
12.0	1 110	400	840	270	690	210	560	150
16.0	840	330	630	230	530	170	420	130
20.0	670	280	500	200	420	150	320	120
25.0	540	240	400	170	340	130	270	95

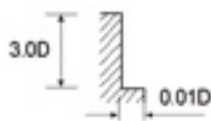

R.P.M. = tours/minute
Avance = mm/minute

CARBURE, 6&8 DENTS HÉLICE 45° SÉRIE NORMALE USINAGE LATÉRAL

réf. C307

■ VITESSE NORMALE

Matière Usinée	Aciers non alliés Aciers alliés		Aciers alliés Aciers réfractaires		Aciers trempés	
DURETÉ	HRc 30		HRc 30 ~ HRc 50		HRc 50 ~ HRc 60	
RESISTANCE	~ 1000N/mm ²		1000 ~ 1750N/mm ²		1750 ~ 2080N/mm ²	
DIAMÈTRE	RPM	Avance	RPM	Avance	RPM	Avance
6.0	5 560	2 000	3 880	1 370	1 580	210
8.0	4 200	2 000	2 940	1 370	1 160	210
10.0	3 360	2 000	2 320	1 370	1 000	210
12.0	2 840	1 680	2 000	1 160	840	180
16.0	2 100	1 260	1 480	880	640	130
20.0	1 680	1 010	1 160	690	500	110
25.0	1 500	900	1 100	600	430	90

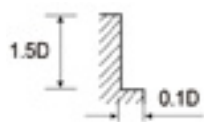

R.P.M. = tours/minute
Avance = mm/minute

■ GRANDE VITESSE

Matière Usinée	Aciers réfractaires Aciers trempés		Aciers trempés	
DURETÉ	HRc 50		HRc 50 ~ HRc 60	
RESISTANCE	~ 1750N/mm ²		1750 ~ 2080N/mm ²	
DIAMÈTRE	RPM	Avance	RPM	Avance
6.0	16 800	6 090	8 400	3 050
8.0	12 600	6 090	6 300	3 050
10.0	9 980	5 990	5 040	3 050
12.0	8 400	5 040	4 200	2 520
16.0	6 300	3 780	3 160	1 890
20.0	5 040	3 050	2 520	1 470
25.0	4 500	2 700	2 200	1 300

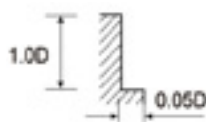

R.P.M. = tours/minute
Avance = mm/minute

CARBURE, HÉMISPHERIQUES 2 DENTS

réf. C310

■ VITESSE NORMALE

Matière Usinée	Aciers non-alliés Aciers alliés Fontes		Aciers alliés Aciers réfractaires		Aciers trempés	
DURETÉ	HRc 30		HRc 30 ~ HRc 40		HRc 45 ~ HRc 55	
RESISTANCE	~ 1000N/mm ²		1000 ~ 1250N/mm ²		1500N/mm ² ~	
DIAMETRE	RPM	Avance	RPM	Avance	RPM	Avance
R0.5 × 1.0	15 760	250	12 720	200	5 800	90
R0.75 × 1.5	15 760	350	12 140	270	5 320	120
R1.0 × 2.0	14 400	750	10 700	490	4 680	150
R1.25 × 2.5	14 400	750	10 700	490	4 680	150
R1.5 × 3.0	13 100	680	10 000	460	4 520	150
R2.0 × 4.0	10 500	740	8 400	530	4 200	180
R2.5 × 5.0	9 140	820	7 300	580	3 680	180
R3.0 × 6.0	8 490	1 020	6 900	830	3 180	190
R4.0 × 8.0	7 160	1 290	5 770	920	2 470	220
R5.0 × 10.0	6 370	1 530	5 090	1 020	2 040	225
R6.0 × 12.0	5 840	1 750	4 640	1 110	1 750	245
R8.0 × 16.0	4 770	1 720	3 780	1 060	1 350	245
R10.0 × 20.0	4 140	1 660	3 260	1 040	1 110	250

ap: D1~D6=0.2mm
D8~D20=0.3mm
ae: 0.2xD

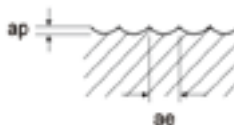

ap: D1~D6=0.2mm
D8~D20=0.3mm
ae: 0.1xD

R.P.M. = tours/minute
Avance = mm/minute

■ GRANDE VITESSE

Matière Usinée	Aciers non-alliés Aciers alliés Fontes		Aciers trempés	
DURETÉ	~ HRc 45		HRc 45 ~ HRc 55	
RESISTANCE	~ 1500N/mm ²		1500N/mm ² ~	
DIAMETRE	RPM	Avance	RPM	Avance
R0.5 × 1.0	25 000	1 300	25 000	800
R0.75 × 1.5	23 000	1 400	23 000	860
R1.0 × 2.0	21 000	1 480	21 000	940
R1.25 × 2.5	21 000	1 760	19 000	980
R1.5 × 3.0	21 000	2 000	17 000	1 040
R2.0 × 4.0	21 000	2 940	13 660	1 160
R2.5 × 5.0	21 000	3 600	12 000	1 200
R3.0 × 6.0	21 000	4 000	10 500	1 250
R4.0 × 8.0	16 700	4 000	8 360	1 250
R5.0 × 10.0	14 000	3 900	7 000	1 200
R6.0 × 12.0	12 200	3 900	6 100	1 160
R8.0 × 16.0	9 550	3 450	4 770	1 000
R10.0 × 20.0	7 960	3 180	3 980	920

ap: D1~D6=0.2n
D8~D20=0.3n
ae: 0.05

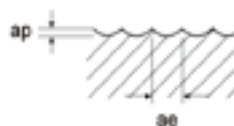

R.P.M. = tours/minute
Avance = mm/minute

CARBURE, HÉMISPHERIQUES 4 DENTS SÉRIE LONGUE

réf. C321

■ VITESSE NORMALE

Matière Usinée	Aciers non-alliés Aciers alliés Fontes		Aciers alliés Aciers réfractaires		Aciers trempés	
DURETÉ	~ HRc30		HRc30 ~ HRc40		HRc45 ~ HRc65	
RESISTANCE	~ 1000N/mm ²		1000 ~ 1250N/mm ²		1500N/mm ² ~	
DIAMETRE	RPM	Avance	RPM	Avance	RPM	Avance
R0.5 × 1.0	15 760	380	12 720	300	5 800	130
R0.75 × 1.5	15 760	530	12 140	410	5 320	180
R1.0 × 2.0	15 760	800	11 560	480	4 840	160
R1.5 × 3.0	13 100	1 020	10 000	690	4 520	220
R2.0 × 4.0	10 500	1 110	8 400	800	4 200	270
R2.5 × 5.0	9 140	1 230	7 300	870	3 680	270
R3.0 × 6.0	8 490	1 530	6 900	1 250	3 180	280
R4.0 × 8.0	7 160	1 950	5 770	1 380	2 470	330
R5.0 × 10.0	6 370	2 300	5 090	1 530	2 040	340
R6.0 × 12.0	5 840	2 600	4 640	1 650	1 750	370
R8.0 × 16.0	4 770	2 600	3 780	1 600	1 350	370
R10.0 × 20.0	4 140	2 500	3 260	1 560	1 110	375

ap: D1~D6=0.2mm
D8~D20=0.3mm
ae: 0.2xD

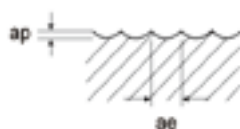

ap: D1~D6=0.2mm
D8~D20=0.3mm
ae: 0.1xD

R.P.M. = tours/minute
Avance = mm/minute

■ GRANDE VITESSE











Matière Usinée	Aciers non-alliés Aciers alliés Fontes		Aciers trempés	
DURETÉ	~ HRc45		HRc45 ~ HRc65	
RESISTANCE	~ 1500N/mm ²		1500N/mm ² ~	
DIAMETRE	RPM	Avance	RPM	Avance
R0.5 × 1.0	25 000	1 950	25 000	1 200
R0.75 × 1.5	23 000	2 100	23 000	1 290
R1.0 × 2.0	21 000	2 200	21 000	1 400
R1.5 × 3.0	21 000	3 000	17 000	1 560
R2.0 × 4.0	21 000	4 400	13 660	1 740
R2.5 × 5.0	21 000	5 400	12 000	1 800
R3.0 × 6.0	21 000	6 000	10 500	1 880
R4.0 × 8.0	16 700	6 000	8 360	1 880
R5.0 × 10.0	14 000	5 850	7 000	1 800
R6.0 × 12.0	12 200	5 850	6 100	1 740
R8.0 × 16.0	9 550	5 180	4 770	1 500
R10.0 × 20.0	7 960	4 770	3 980	1 380

ap: D1~D6=0.2mm
D8~D20=0.3mm
ae: 0.05xD



R.P.M. = tours/minute
Avance = mm/minute

FRAISES CARBURE GÉNÉRAL

			LISTE DES MATIÈRES									
			aciers jusqu'à HB325	aciers jusqu'à 40HRc	aciers jusqu'à 45HRc	aciers INOX	fontes	Cuivre	Titane	Inconel	ALU	plastiques
C600	Fraises carbure 2 dents cylindriques série normale		p. 79	●	●	●	●	●			●	
C600K	Fraises carbure 2 dents cylindriques série normale revêtues TiAlN		p. 80	●	●	●	●	●	●	●	●	
C604	Fraises carbure 2 dents cylindriques extra longues		p. 80	●	●	●	●	●			●	
C604X	Fraises carbure 2 dents cylindriques extra longues revêtues TiAlN		p. 81	●	●	●	●	●	●	●	●	
605K	Fraises carbure 3 dents à méplat extra courtes revêtues TiAlN		p. 81	●	●	●	●	●	●	●	●	
C609	Fraises carbure 3 dents cylindriques série normale		p. 82	●	●	●	●	●			●	
609K	Fraises carbure 3 dents cylindriques série normale revêtues TiAlN		p. 82	●	●	●	●	●	●	●	●	
C611	Fraises carbure 3 dents cylindriques série normale 45° pour Aluminium		p. 83	●	●			●			●	●
C613K	Fraises carbure 3 dents à méplat série normale 45° revêtues TiAlN pour Aluminium		p. 83	●	●			●	●	●	●	●
C617	Fraises carbure 4 dents cylindriques série normale		p. 84	●	●	●	●	●			●	
C617K	Fraises carbure 4 dents cylindriques série normale revêtues TiAlN		p. 84	●	●	●	●	●	●	●	●	

suite page suivante

● utilisation conseillée pour la matière concernée.











DONNÉES TECHNIQUES

Conditions de coupe recommandées

pages 92 à 100

FRAISES CARBURE GÉNÉRAL

LISTE DES MATIÈRES

				aciers jusqu'à HB325	aciers jusqu'à 40HRc	aciers jusqu'à 45HRc	aciers INOX	fontes	Cuivre	Titane	Inconel	ALU	plastiques
C618	Fraises carbure 4 dents cylindriques extra longues		p. 85	●	●		●	●	●			●	
C618X	Fraises carbure 4 dents cylindriques extra longues revêtues TiAlN		p. 85	●	●		●	●	●			●	
C631K	Fraises carbure ébauche à méplat série normale revêtues TiAlN		p. 86	●	●		●	●	●	●	●	●	
C630K	Fraises carbure 2 dents hémisphérique cylindriques revêtues TiAlN série normale		p. 86	●	●	●	●	●	●	●	●	●	
C623K	Fraises carbure 2 dents hémisphérique cylindriques extra longues revêtues TiAlN		p. 87	●	●	●	●	●	●	●	●	●	
C632K	Fraises carbure 2 dents cylindriques série normale queue dégagée revêtues TiAlN		p. 88	●	●		●	●	●			●	
C633K	Fraises carbure 2 dents hémisphériques cylindriques série normale queue dégagée revêtues TiAlN		p. 89	●	●		●	●	●			●	
C634K	Fraises carbure 2 dents toriques cylindriques série normale revêtues TiAlN		p. 90	●	●		●	●	●			●	
C636K	Fraises carbure 4 dents toriques cylindriques série normale revêtues TiAlN		p. 91	●	●		●	●	●			●	
C626X	Fraises foret carbure 2 dents MULTI-V cylindriques revêtues TiAlN		p. 91	●	●	●	●	●					

● utilisation conseillée pour la matière concernée.

DONNÉES TECHNIQUES

Conditions de coupe recommandées
pages 92 à 100

FRAISES CARBURE 2 DENTS CYLINDRIQUES SÉRIE NORMALE STANDARD CORAI



réf. C600

conditions de coupe recommandées p. 92

Ø fraisage	Dimensions	Réf.	Prix unitaire TARIF H.T.
1.0	1x4x3x40	C600 0100	19.46 €
1.5	1.5x4x4.5x40	C600 0150	18.56 €
2.0	2x2x8x32	C600 0200	15.47 €
2.5	2.5x2.5x8.0x32	C600 0250	15.47 €
3.0	3x3x12x32	C600 0300	15.47 €
3.5	3.5x3.5x12x32	C600 0350	17.68 €
4.0	4x4x12x40	C600 0400	17.68 €
4.5	4.5x4.5x14x50	C600 0450	18.73 €
5.0	5x5x14x50	C600 0500	18.73 €
5.5	5.5x5.5x16x50	C600 0550	21.06 €
6.0	6x6x16x50	C600 0600	21.06 €
7.0	7x7x20x60	C600 0700	26.95 €
8.0	8x8x20x60	C600 0800	33.74 €
9.0	9x9x20x60	C600 0900	47.50 €
10.0	10x10x22x70	C600 1000	50.89 €
12.0	12x12x22x70	C600 1200	71.23 €
14.0	14x14x25x75	C600 1400	97.11 €
16.0	16x16x25x75	C600 1600	123.53 €
20.0	20x20x32x100	C600 2000	206.19 €

Tolérances selon DIN 7160 & 7161

Plage de tolérance en µm					
	Diamètre nominal en mm				
	de 1 à 3	plus de 3 à 6	plus de 6 à 10	plus de 10 à 18	plus de 18 à 30
h10	0 - 40	0 - 48	0 - 58	0 - 70	0 - 84
h6	0 - 6	0 - 8	0 - 9	0 - 11	0 - 13

FRAISES CARBURE 2 DENTS CYLINDRIQUES SÉRIE NORMALE REVÊTUES TiAIN STANDARD CORAI



réf. C600K

conditions de coupe recommandées p. 92

Ø fraise	Dimensions	Réf.	Prix unitaire TARIF H.T.	Ø fraise	Dimensions	Réf.	Prix unitaire TARIF H.T.
1.0	1.0x4x3x40	C600 0100 K	22.45 €	6.0	6.0x6x16x50	C600 0600 K	24.03 €
1.5	1.5x4x4.5x40	C600 0150 K	21.58 €	7.0	7x7x20x60	C600 0700 K	32.25 €
2.0	2.0x2x8x32	C600 0200 K	18.53 €	8.0	8.0x8x20x60	C600 0800 K	38.92 €
2.5	2.5x2.5x8x32	C600 0250 K	18.53 €	9.0	9x9x20x60	C600 0900 K	52.65 €
3.0	3.0x3x12x32	C600 0300 K	18.53 €	10.0	10.0x10x22x70	C600 1000 K	58.69 €
3.5	3.5x3.5x12x32	C600 0350 K	20.71 €	12.0	12.0x12x22x70	C600 1200 K	80.23 €
4.0	4.0x4x12x40	C600 0400 K	20.71 €	14.0	14.0x14x25x75	C600 1400 K	107.12 €
4.5	4.5x4.5x14x50	C600 0450 K	21.71 €	16.0	16.0x16x25x75	C600 1600 K	140.67 €
5.0	5.0x5x14x50	C600 0500 K	21.71 €	20.0	20.0x20x32x100	C600 2000 K	238.24 €
5.5	5.5x5.5x16x50	C600 0550 K	24.03 €				

tolérance fraises (mm)	tolérance Ø queue
0--0.03	h6

FRAISES CARBURE 2 DENTS CYLINDRIQUES EXTRA LONGUES STANDARD CORAI



réf. C604

conditions de coupe recommandées p. 92

Ø fraise	Dimensions	Réf.	Prix unitaire TARIF H.T.	Ø fraise	Dimensions	Réf.	Prix unitaire TARIF H.T.
3.0	3x3x30x75	C604 0300	31.61 €	12.0	12x12x75x150	C604 1200	154.35 €
4.0	4x4x30x75	C604 0400	33.81 €	14.0	14x14x65x150	C604 1400	197.86 €
5.0	5x5x40x100	C604 0500	44.32 €	16.0	16x16x65x150	C604 1600	289.55 €
6.0	6x6x50x150	C604 0600	54.70 €	18.0	18x18x65x150	C604 1800	304.07 €
8.0	8x8x50x150	C604 0800	83.31 €	20.0	20x20x65x150	C604 2000	400.54 €
10.0	10x10x60x150	C604 1000	101.59 €				

Tolérances selon DIN 7160 & 7161

Plage de tolérance en µm					
Diamètre nominal en mm					
	de 1 à 3	plus de 3 à 6	plus de 6 à 10	plus de 10 à 18	plus de 18 à 30
h10	0 - 40	0 - 48	0 - 58	0 - 70	0 - 84
h6	0 - 6	0 - 8	0 - 9	0 - 11	0 - 13

FRAISES CARBURE 2 DENTS CYLINDRIQUES EXTRA LONGUES REVÊTUES TiAIN STANDARD CORAI



réf. C604X

conditions de coupe recommandées p. 92

Ø fraise	Dimensions	Réf.	Prix unitaire TARIF H.T.	Ø fraise	Dimensions	Réf.	Prix unitaire TARIF H.T.
3.0	3x3x30x75	C604 0300 X	38.51 €	12.0	12x12x75x150	C604 1200 X	181.85 €
4.0	4x4x30x75	C604 0400 X	40.66 €	14.0	14x14x65x150	C604 1400 X	225.52 €
5.0	5x5x40x100	C604 0500 X	54.97 €	16.0	16x16x65x150	C604 1600 X	317.59 €
6.0	6x6x50x150	C604 0600 X	74.68 €	18.0	18x18x65x150	C604 1800 X	341.08 €
8.0	8x8x50x150	C604 0800 X	106.28 €	20.0	20x20x65x150	C604 2000 X	445.87 €
10.0	10x10x60x150	C604 1000 X	129.02 €				

tolérance fraises (mm)	tolérance Ø queue
0~-0.03	h6

FRAISES CARBURE 3 DENTS À MÉPLAT EXTRA COURTES REVÊTUES TiAIN STANDARD CORAI



réf. C605K

conditions de coupe recommandées p. 94

Ø fraise	Dimensions	Réf.	Prix unitaire TARIF H.T.	Ø fraise	Dimensions	Réf.	Prix unitaire TARIF H.T.
2.0	2X6X4X35	C605 0200 K	20.58 €	7.75	7.75X8X10X42	C605 0775 K	30.21 €
2.5	2.5X6X5X36	C605 0250 K	21.46 €	8.0	8X8X11X43	C605 0800 K	30.01 €
3.0	3X6X5X36	C605 0300 K	20.58 €	8.7	8.7X10X11X48	C605 0870 K	46.65 €
3.5	3.5X6X6X37	C605 0350 K	22.33 €	9.0	9X10X11X48	C605 0900 K	42.99 €
4.0	4X6X7X38	C605 0400 K	20.58 €	9.7	9.7X10X11X48	C605 0970 K	46.65 €
4.5	4.5X6X8X38	C605 0450 K	22.33 €	10.0	10X10X13X50	C605 1000 K	44.93 €
5.0	5X6X8X39	C605 0500 K	20.58 €	12.0	12X12X15X55	C605 1200 K	53.33 €
5.5	5.5X6X8X39	C605 0550 K	22.33 €	14.0	14X14X15X58	C605 1400 K	79.10 €
5.75	5.75X6X8X39	C605 0575 K	22.33 €	16.0	16X16X18X62	C605 1600 K	93.39 €
6.0	6X6X8X39	C605 0600 K	20.58 €	18.0	18X18X20X70	C605 1800 K	115.15 €
6.75	6.75X8X10X42	C605 0675 K	30.21 €	20.0	20X20X22X75	C605 2000 K	151.66 €
7.0	7X8X10X42	C605 0700 K	28.01 €				

tolérance fraises (mm)	tolérance Ø queue
0~-0.03	h6

FRAISES CARBURE 3 DENTS CYLINDRIQUES SÉRIE NORMALE DIN 6528



réf. C609

conditions de coupe recommandées p. 93

Ø fraisage	Dimensions	Réf.	Prix unitaire TARIF H.T.	Ø fraisage	Dimensions	Réf.	Prix unitaire TARIF H.T.
3.5	3.5X3.5X7X50	C609 0350	17.68 €	9.0	9X9X16X67	C609 0900	50.46 €
4.0	4X4X8X50	C609 0400	17.68 €	9.5	9.5X9.5X19X72	C609 0950	54.03 €
4.5	4.5X4.5X8X50	C609 0450	18.73 €	10.0	10X10X19X72	C609 1000	54.03 €
5.0	5X5X10X50	C609 0500	18.73 €	11.0	11X11X22X83	C609 1100	77.30 €
5.5	5.5X5.5X10X57	C609 0550	28.51 €	12.0	12X12X22X83	C609 1200	77.30 €
6.0	6X6X10X57	C609 0600	28.51 €	13.0	13X13X22X83	C609 1300	99.55 €
6.5	6.5X6.5X13X60	C609 0650	30.48 €	14.0	14X14X22X83	C609 1400	99.55 €
7.0	7X7X13X60	C609 0700	30.48 €	15.0	15X15X26X92	C609 1500	133.53 €
7.5	7.5X7.5X16X63	C609 0750	33.50 €	16.0	16X16X26X92	C609 1600	133.53 €
8.0	8X8X16X63	C609 0800	33.50 €	18.0	18X18X26X92	C609 1800	175.66 €
8.5	8.5X8.5X16X67	C609 0850	50.46 €	20.0	20X20X32X104	C609 2000	217.91 €

Tolérances selon DIN 7160 & 7161

Plage de tolérance en µm					
Diamètre nominal en mm					
	de 1 à 3	plus de 3 à 6	plus de 6 à 10	plus de 10 à 18	plus de 18 à 30
h10	0 - 40	0 - 48	0 - 58	0 - 70	0 - 84
h6	0 - 6	0 - 8	0 - 9	0 - 11	0 - 13

FRAISES CARBURE 3 DENTS CYLINDRIQUES SÉRIE NORMALE REVÊTUES TiAIN DIN 6528



réf. C609K

conditions de coupe recommandées p. 94

Ø fraisage	Dimensions	Réf.	Prix unitaire TARIF H.T.	Ø fraisage	Dimensions	Réf.	Prix unitaire TARIF H.T.
3.5	3.5X3.5X7X50	C609 0350 K	20.71 €	9.0	9x9x16x67	C609 0900 K	55.83 €
4.0	4X4X8X50	C609 0400 K	20.71 €	9.5	9.5x9.5x19x72	C609 0950 K	59.27 €
4.5	4.5X4.5X8X50	C609 0450 K	21.71 €	10.0	10x10x19x72	C609 1000 K	59.27 €
5.0	5x5x10x50	C609 0500 K	21.71 €	11.0	11x11x22x83	C609 1100 K	86.71 €
5.5	5.5x5.5x10x57	C609 0550 K	30.90 €	12.0	12X12X22X83	C609 1200 K	86.71 €
6.0	6x6x10x57	C609 0600 K	30.90 €	13.0	13x13x22x83	C609 1300 K	109.80 €
6.5	6.5x6.5x13x60	C609 0650 K	35.67 €	14.0	14x14x22x83	C609 1400 K	110.42 €
7.0	7x7x13x60	C609 0700 K	35.67 €	15.0	15x15x26x92	C609 1500 K	145.92 €
7.5	7.5x7.5x16x63	C609 0750 K	38.68 €	16.0	16x16x26x92	C609 1600 K	146.04 €
8.0	8x8x16x63	C609 0800 K	38.68 €	18.0	18x18x26x92	C609 1800 K	191.22 €
8.5	8.5x8.5x16x67	C609 0850 K	55.83 €	20.0	20x20x32x104	C609 2000 K	240.12 €

tolérance fraises (mm)	tolérance Ø queue
0--0.03	h6

FRAISES CARBURE 3 DENTS CYLINDRIQUES SÉRIE NORMALE 45° POUR ALUMINIUM STANDARD CORAI



réf. C611

conditions de coupe recommandées p. 93

Ø fraise	Dimensions	Réf.	Prix unitaire TARIF H.T.	Ø fraise	Dimensions	Réf.	Prix unitaire TARIF H.T.
3.0	3x6x8x45	C611 0300 M	28.51 €	10.0	10x10x22x70	C611 1000 M	59.44 €
4.0	4x6x11x45	C611 0400 M	28.51 €	12.0	12x12x26x75	C611 1200 M	88.90 €
5.0	5x6x13x50	C611 0500 M	28.51 €	14.0	14x14x26x75	C611 1400 M	114.48 €
6.0	6x6x13x50	C611 0600 M	28.51 €	16.0	16x16x25x75	C611 1600 M	153.59 €
8.0	8x8x19x60	C611 0800 M	36.46 €	20.0	20x20x32x100	C611 2000 M	239.64 €

Tolérances selon DIN 7160 & 7161

Plage de tolérance en µm					
Diamètre nominal en mm					
	de 1 à 3	plus de 3 à 6	plus de 6 à 10	plus de 10 à 18	plus de 18 à 30
h10	0 - 40	0 - 48	0 - 58	0 - 70	0 - 84
h6	0 - 6	0 - 8	0 - 9	0 - 11	0 - 13

FRAISES CARBURE 3 DENTS À MÉPLAT SÉRIE NORMALE 45° REVÊTUES TiAIN POUR ALUMINIUM STANDARD CORAI



réf. C613K

conditions de coupe recommandées p. 94

Ø fraise	Dimensions	Réf.	Prix unitaire TARIF H.T.	Ø fraise	Dimensions	Réf.	Prix unitaire TARIF H.T.
3.0	3.0x6x7x57	C613 0300 KM	36.86 €	9.0	9x10x16x72	C613 0900 KM	71.06 €
3.5	3.5x6x7x57	C613 0350 KM	36.86 €	10.0	10.0x10x19x72	C613 1000 KM	71.06 €
4.0	4.0x6x8x57	C613 0400 KM	36.86 €	12.0	12.0x12x22x83	C613 1200 KM	102.56 €
4.5	4.5x6x8x57	C613 0450 KM	36.86 €	14.0	14.0x14x22x83	C613 1400 KM	130.95 €
5.0	5.0x6x10x57	C613 0500 KM	36.86 €	16.0	16.0x16x26x92	C613 1600 KM	173.49 €
6.0	6.0x6x10x57	C613 0600 KM	36.86 €	18.0	18x18x26x92	C613 1800 KM	227.33 €
7.0	7x8x13x63	C613 0700 KM	45.22 €	20.0	20.0x20x32x104	C613 2000 KM	273.81 €
8.0	8.0x8x16x63	C613 0800 KM	45.22 €				

tolérance fraises (mm)	tolérance Ø queue
0~-0.03	h6

FRAISES CARBURE 4 DENTS CYLINDRIQUES SÉRIE NORMALE DIN 6528



réf. C617

conditions de coupe recommandées p. 95

Ø fraise	Dimensions	Réf.	Prix unitaire TARIF H.T.	Ø fraise	Dimensions	Réf.	Prix unitaire TARIF H.T.
3.5	3.5X3.5X10X50	C617 0350	17.68 €	9.0	9X9X19X67	C617 0900	50.46 €
4.0	4X4X11X50	C617 0400	17.68 €	9.5	9.5X9.5X22X72	C617 0950	54.03 €
4.5	4.5X4.5X11X50	C617 0450	18.73 €	10.0	10X10X22X72	C617 1000	54.03 €
5.0	5X5X13X50	C617 0500	18.73 €	11.0	11X11X26X83	C617 1100	77.30 €
5.5	5.5X5.5X13X57	C617 0550	28.51 €	12.0	12X12X26X83	C617 1200	77.30 €
6.0	6X6X13X57	C617 0600	28.51 €	13.0	13X13X26X83	C617 1300	99.55 €
6.5	6.5X6.5X16X60	C617 0650	30.48 €	14.0	14X14X26X83	C617 1400	99.55 €
7.0	7X7X16X60	C617 0700	30.48 €	15.0	15X15X32X92	C617 1500	133.53 €
7.5	7.5X7.5X19X63	C617 0750	33.50 €	16.0	16X16X32X92	C617 1600	133.53 €
8.0	8X8X19X63	C617 0800	33.50 €	18.0	18X18X32X92	C617 1800	175.66 €
8.5	8.5X8.5X19X67	C617 0850	50.46 €	20.0	20X20X38X104	C617 2000	217.91 €

Tolérances selon DIN 7160 & 7161

Plage de tolérance en µm					
Diamètre nominal en mm					
	de 1 à 3	plus de 3 à 6	plus de 6 à 10	plus de 10 à 18	plus de 18 à 30
h10	0 - 40	0 - 48	0 - 58	0 - 70	0 - 84
h6	0 - 6	0 - 8	0 - 9	0 - 11	0 - 13

FRAISES CARBURE 4 DENTS CYLINDRIQUES SÉRIE NORMALE REVÊTUES TiAIN DIN 6528



réf. C617K

conditions de coupe recommandées p. 95

Ø fraise	Dimensions	Réf.	Prix unitaire TARIF H.T.	Ø fraise	Dimensions	Réf.	Prix unitaire TARIF H.T.
3.5	3.5x3.5x10x50	C617 0350 K	20.71 €	9.0	9x9x19x67	C617 0900 K	55.83 €
4.0	4x4x11x50	C617 0400 K	20.71 €	9.5	9.5x9.5x22x72	C617 0950 K	59.27 €
4.5	4.5x4.5x11x50	C617 0450 K	21.71 €	10.0	10x10x22x72	C617 1000 K	59.27 €
5.0	5.0x5.0x13x50	C617 0500 K	21.71 €	11.0	11x11x26x83	C617 1100 K	86.71 €
5.5	5.5x5.5x13x57	C617 0550 K	30.90 €	12.0	12X12X26X83	C617 1200 K	86.71 €
6.0	6x6x13x57	C617 0600 K	30.90 €	13.0	13x13x26x83	C617 1300 K	109.80 €
6.5	6.5x6.5x16x60	C617 0650 K	35.67 €	14.0	14x14x26x83	C617 1400 K	110.42 €
7.0	7x7x16x60	C617 0700 K	35.67 €	15.0	15x15x32x92	C617 1500 K	145.92 €
7.5	7.5x7.5x19x63	C617 0750 K	38.68 €	16.0	16x16x32x92	C617 1600 K	146.04 €
8.0	8x8x19x63	C617 0800 K	38.68 €	18.0	18x18x32x92	C617 1800 K	191.22 €
8.5	8.5x8.5x19x67	C617 0850 K	55.83 €	20.0	20x20x38x104	C617 2000 K	240.12 €

tolérance fraises (mm)	tolérance Ø queue
0--0.03	h6

FRAISES CARBURE 4 DENTS CYLINDRIQUES EXTRA LONGUES STANDARD CORAI



réf. C618

conditions de coupe recommandées p. 95

Ø fraise	Dimensions	Réf.	Prix unitaire TARIF H.T.	Ø fraise	Dimensions	Réf.	Prix unitaire TARIF H.T.
3.0	3x3x30x75	C618 0300	31.61 €	12.0	12X12X75X150	C618 1200	154.35 €
4.0	4X4X30X75	C618 0400	33.81 €	14.0	14X14X65X150	C618 1400	197.87 €
5.0	5X5X40X100	C618 0500	44.32 €	16.0	16X16X65X150	C618 1600	289.55 €
6.0	6X6X50X150	C618 0600	54.70 €	18.0	18X18X65X150	C618 1800	304.02 €
8.0	8X8X50X150	C618 0800	83.31 €	20.0	20X20X65X150	C618 2000	400.54 €
10.0	10X10X60X150	C618 1000	101.59 €				

Tolérances selon DIN 7160 & 7161

Plage de tolérance en µm					
Diamètre nominal en mm					
	de 1 à 3	plus de 3 à 6	plus de 6 à 10	plus de 10 à 18	plus de 18 à 30
h10	0 - 40	0 - 48	0 - 58	0 - 70	0 - 84
h6	0 - 6	0 - 8	0 - 9	0 - 11	0 - 13

FRAISES CARBURE 4 DENTS CYLINDRIQUES EXTRA LONGUES REVÊTUES TiAIN STANDARD CORAI



réf. C618X

conditions de coupe recommandées p. 95

Ø fraise	Dimensions	Réf.	Prix unitaire TARIF H.T.	Ø fraise	Dimensions	Réf.	Prix unitaire TARIF H.T.
3.0	3x3x30x75	C618 0300 X	38.51 €	12.0	12X12X75X150	C618 1200 X	181.85 €
4.0	4X4X30X75	C618 0400 X	40.66 €	14.0	14X14X65X150	C618 1400 X	225.52 €
5.0	5X5X40X100	C618 0500 X	54.97 €	16.0	16X16X65X150	C618 1600 X	317.61 €
6.0	6X6X50X150	C618 0600 X	74.68 €	18.0	18X18X65X150	C618 1800 X	341.09 €
8.0	8X8X50X150	C618 0800 X	106.28 €	20.0	20X20X65X150	C618 2000 X	445.87 €
10.0	10X10X60X150	C618 1000 X	129.02 €				

tolérance fraises (mm)	tolérance Ø queue
0~-0.03	h6

FRAISES CARBURE ÉBAUCHE À MÉPLAT SÉRIE NORMALE REVÊTUES TiAIN DIN 6535 HB



réf. C631K

conditions de coupe recommandées p. 96

Ø fraise	Dimensions	Réf.	Prix unitaire TARIF H.T.	Ø fraise	Dimensions	Réf.	Prix unitaire TARIF H.T.
6.0	6x6x16x57	C631 0600 KM	44.49 €	16.0	16x16x32x92	C631 1600 KM	167.95 €
8.0	8x8x16x63	C631 0800 KM	49.22 €	18.0	18x18x32x92	C631 1800 KM	223.78 €
10.0	10x10x22x72	C631 1000 KM	79.29 €	20.0	20x20x38x104	C631 2000 KM	254.92 €
12.0	12x12x26x83	C631 1200 KM	107.73 €	25.0	25x25x45x121	C631 2500 KM	543.73 €
14.0	14x14x26x83	C631 1400 KM	131.68 €				

Tolérances selon DIN 7160 & 7161

Plage de tolérance en µm					
Diamètre nominal en mm					
	de 1 à 3	plus de 3 à 6	plus de 6 à 10	plus de 10 à 18	plus de 18 à 30
h10	0 - 40	0 - 48	0 - 58	0 - 70	0 - 84
h6	0 - 6	0 - 8	0 - 9	0 - 11	0 - 13

FRAISES CARBURE 2 DENTS HÉMISPHERIQUE CYLINDRIQUES SÉRIE NORMALE REVÊTUES TiAIN DIN 6535 HA



réf. C630K

conditions de coupe recommandées p. 96

Ø fraise	Dimensions	Réf.	Prix unitaire TARIF H.T.	Ø fraise	Dimensions	Réf.	Prix unitaire TARIF H.T.
1.0	1X3X3X39	C630 0100 K	23.47 €	6.0	6X6X19X64	C630 0600 K	35.18 €
1.5	1.5X3X5X39	C630 0150 K	23.47 €	8.0	8X8X21X64	C630 0800 K	59.27 €
2.0	2X3X7X39	C630 0200 K	23.47 €	10.0	10X10X22X70	C630 1000 K	96.02 €
2.5	2.5X3X8X39	C630 0250 K	23.47 €	12.0	12X12X25X76	C630 1200 K	123.58 €
3.0	3X3X9X39	C630 0300 K	23.47 €	16.0	16X16X32X89	C630 1600 K	197.32 €
4.0	4X4X14X51	C630 0400 K	25.96 €	20.0	20X20X38X102	C630 2000 K	302.38 €
5.0	5X5X16X51	C630 0500 K	26.51 €				

tolérance fraises (mm)	tolérance Ø queue
0--0.03	h6

FRAISES CARBURE 2 DENTS HÉMISPHERIQUE CYLINDRIQUES EXTRA LONGUES REVÊTUES TiAIN DIN 6535 HA



réf. C623K

conditions de coupe recommandées p. 96

Ø fraisage	Dimensions	Réf.	Prix unitaire TARIF H.T.
3.0	3X3X20X60	C623 03001 K	37.06 €
4.0	4X4X20X60	C623 04001 K	38.80 €
5.0	5X5X25X75	C623 05001 K	48.11 €
6.0	6X6X30X75	C623 06001 K	51.97 €
8.0	8X8X30X75	C623 08001 K	76.35 €
10.0	10X10X40X100	C623 10001 K	106.87 €

Ø fraisage	Dimensions	Réf.	Prix unitaire TARIF H.T.
12.0	12X12X45X100	C623 12001 K	159.52 €
14.0	14X14X45X100	C623 14001 K	204.45 €
16.0	16X16X45X100	C623 16001 K	269.81 €
18.0	18X18X45X100	C623 18001 K	304.12 €
20.0	20X20X45X100	C623 20001 K	360.76 €

tolérance fraises (mm)	tolérance Ø queue
0~-0.03	h6

FRAISES CARBURE 2 DENTS CYLINDRIQUES SÉRIE NORMALE QUEUE DÉGAGÉE REVÊTUES TiAIN DIN 6535 HA



réf. C632K

conditions de coupe recommandées p. 97

Ø fraiseage	Dimensions	Réf.	Prix unitaire TARIF H.T.	Ø fraiseage	Dimensions	Réf.	Prix unitaire TARIF H.T.
0,4	0,4x4x0,7x2x50	C632 0040 020 K	46.25 €	1,5	1,5x4x2,3x14x50	C632 0150 140 K	36.28 €
0,4	0,4x4x0,7x4x50	C632 0040 040 K	46.25 €	1,5	1,5x4x2,3x16x50	C632 0150 160 K	37.78 €
0,5	0,5x4x0,75x2x50	C632 0050 020 K	42.31 €	1,5	1,5x4x2,3x18x50	C632 0150 180 K	37.78 €
0,5	0,5x4x0,75x4x50	C632 0050 040 K	42.31 €	1,5	1,5x4x2,3x20x50	C632 0150 200 K	37.78 €
0,5	0,5x4x0,75x6x50	C632 0050 060 K	42.31 €	2,0	2x4x3x6x50	C632 0200 060 K	32.58 €
0,6	0,6x4x0,9x2x50	C632 0060 020 K	42.31 €	2,0	2x4x3x8x50	C632 0200 080 K	32.58 €
0,6	0,6x4x0,9x4x50	C632 0060 040 K	42.31 €	2,0	2x4x3x10x50	C632 0200 100 K	32.58 €
0,6	0,6x4x0,9x6x50	C632 0060 060 K	42.31 €	2,0	2x4x3x12x50	C632 0200 120 K	32.58 €
0,7	0,7x4x1,1x4x50	C632 0070 040 K	38.41 €	2,0	2x4x3x14x50	C632 0200 140 K	32.58 €
0,7	0,7x4x1,1x6x50	C632 0070 060 K	38.41 €	2,0	2x4x3x16x50	C632 0200 160 K	33.88 €
0,8	0,8x4x1,2x4x50	C632 0080 040 K	38.41 €	2,0	2x4x3x18x50	C632 0200 180 K	33.88 €
0,8	0,8x4x1,2x6x50	C632 0080 060 K	38.41 €	2,0	2x4x3x20x50	C632 0200 200 K	33.88 €
0,8	0,8x4x1,2x8x50	C632 0080 080 K	38.41 €	2,5	2,5x4x3,7x8x50	C632 0250 080 K	32.58 €
0,9	0,9x4x1,4x6x50	C632 0090 060 K	38.41 €	2,5	2,5x4x3,7x12x50	C632 0250 120 K	32.58 €
0,9	0,9x4x1,4x8x50	C632 0090 080 K	38.41 €	2,5	2,5x4x3,7x16x50	C632 0250 160 K	33.88 €
0,9	0,9x4x1,4x10x50	C632 0090 100 K	38.41 €	2,5	2,5x4x3,7x20x50	C632 0250 200 K	33.88 €
1,0	1x4x1,5x6x50	C632 0100 060 K	34.21 €	3,0	3x6x4,5x8x50	C632 0300 080 K	49.02 €
1,0	1x4x1,5x8x50	C632 0100 080 K	34.21 €	3,0	3x6x4,5x12x50	C632 0300 120 K	49.02 €
1,0	1x4x1,5x10x50	C632 0100 100 K	34.21 €	3,0	3x6x4,5x16x60	C632 0300 160 K	50.27 €
1,0	1x4x1,5x12x50	C632 0100 120 K	36.28 €	3,0	3x6x4,5x20x60	C632 0300 200 K	50.27 €
1,2	1,2x4x1,8x6x50	C632 0120 060 K	34.21 €	3,0	3x6x6x25x75	C632 0300 250 K	50.27 €
1,2	1,2x4x1,8x8x50	C632 0120 080 K	34.21 €	4,0	4x6x6x12x50	C632 0400 120 K	49.02 €
1,2	1,2x4x1,8x10x50	C632 0120 100 K	34.21 €	4,0	4x6x6x16x60	C632 0400 160 K	50.27 €
1,2	1,2x4x1,8x12x50	C632 0120 120 K	36.28 €	4,0	4x6x6x20x75	C632 0400 200 K	50.27 €
1,5	1,5x4x2,3x6x50	C632 0150 060 K	34.21 €	4,0	4x6x6x25x75	C632 0400 250 K	50.27 €
1,5	1,5x4x2,3x8x50	C632 0150 080 K	34.21 €	4,0	4x6x6x30x75	C632 0400 300 K	58.07 €
1,5	1,5x4x2,3x10x50	C632 0150 100 K	34.21 €	4,0	4x6x6x35x75	C632 0400 350 K	63.27 €
1,5	1,5x4x2,3x12x50	C632 0150 120 K	36.28 €				

tolérance fraises (mm)	tolérance Ø queue
0--0.03	h6

FRAISES CARBURE 2 DENTS HÉMISPHERIQUES CYLINDRIQUES SÉRIE NORMALE QUEUE DÉGAGÉE REVÊTUES TiAIN DIN 6535 HA



réf. C633K

conditions de coupe recommandées p. 98

Ø fraise	Dimensions	Réf.	Prix unitaire TARIF H.T.	Ø fraise	Dimensions	Réf.	Prix unitaire TARIF H.T.
0,4	0,4x4x0,7x2x50	C633 0040 020 K	73.81 €	1,5	1,5x4x2,3x20x50	C633 0150 200 K	51.41 €
0,5	0,5x4x0,75x2x50	C633 0050 020 K	63.96 €	1,6	1,6x4x2,4x8x50	C633 0160 080 K	45.57 €
0,5	0,5x4x0,75x4x50	C633 0050 040 K	63.96 €	1,6	1,6x4x2,4x12x50	C633 0160 120 K	48.58 €
0,5	0,5x4x0,75x6x50	C633 0050 060 K	73.81 €	1,6	1,6x4x2,4x16x50	C633 0160 160 K	51.41 €
0,6	0,6x4x0,9x2x50	C633 0060 020 K	63.96 €	1,6	1,6x4x2,4x20x50	C633 0160 200 K	51.41 €
0,6	0,6x4x0,9x4x50	C633 0060 040 K	63.96 €	2,0	2x4x3x8x50	C633 0200 080 K	42.61 €
0,6	0,6x4x0,9x6x50	C633 0060 060 K	63.96 €	2,0	2x4x3x10x50	C633 0200 100 K	42.61 €
0,8	0,8x4x1,2x4x50	C633 0080 040 K	49.53 €	2,0	2x4x3x12x50	C633 0200 120 K	42.61 €
0,8	0,8x4x1,2x6x50	C633 0080 060 K	49.53 €	2,0	2x4x3x14x50	C633 0200 140 K	45.19 €
0,8	0,8x4x1,2x8x50	C633 0080 080 K	49.53 €	2,0	2x4x3x16x50	C633 0200 160 K	45.19 €
1,0	1x4x1,5x6x50	C633 0100 060 K	45.57 €	2,0	2x4x3x20x50	C633 0200 200 K	47.12 €
1,0	1x4x1,5x8x50	C633 0100 080 K	45.57 €	3,0	3x6x4,5x10x50	C633 0300 100 K	51.27 €
1,0	1x4x1,5x10x50	C633 0100 100 K	45.57 €	3,0	3x6x4,5x12x50	C633 0300 120 K	51.27 €
1,0	1x4x1,5x12x50	C633 0100 120 K	48.58 €	3,0	3x6x4,5x16x60	C633 0300 160 K	62.07 €
1,2	1,2x4x1,8x8x50	C633 0120 080 K	45.57 €	3,0	3x6x4,5x20x60	C633 0300 200 K	66.73 €
1,2	1,2x4x1,8x12x50	C633 0120 120 K	48.58 €	3,0	3x6x4,5x25x75	C633 0300 250 K	69.04 €
1,4	1,4x4x2,1x16x50	C633 0140 160 K	51.41 €	4,0	4x6x6x12x50	C633 0400 120 K	49.65 €
1,5	1,5x4x2,3x6x50	C633 0150 060 K	45.57 €	4,0	4x6x6x16x60	C633 0400 160 K	62.07 €
1,5	1,5x4x2,3x8x50	C633 0150 080 K	45.57 €	4,0	4x6x6x20x75	C633 0400 200 K	69.04 €
1,5	1,5x4x2,3x10x50	C633 0150 100 K	45.57 €	4,0	4x6x6x25x75	C633 0400 250 K	69.04 €
1,5	1,5x4x2,3x12x50	C633 0150 120 K	48.58 €	4,0	4x6x6x30x75	C633 0400 300 K	71.68 €
1,5	1,5x4x2,3x16x50	C633 0150 160 K	51.41 €				

tolérance fraises (mm)	tolérance Ø queue
0~-0.03	h6

FRAISES CARBURE 2 DENTS TORIQUES CYLINDRIQUES SÉRIE NORMALE REVÊTUES TiAIN DIN 6535 HA



réf. C634K

conditions de coupe recommandées p. 99

Ø fraise	Dimensions	Réf.	Prix unitaire TARIF H.T.	Ø fraise	Dimensions	Réf.	Prix unitaire TARIF H.T.
2.0	2(R0,2)x4x4x50	C634 0200 02 K	23.93 €	6.0	6(R0,3)x6x12x50	C634 0600 03 K	35.52 €
2.0	2(R0,3)x4x4x50	C634 0200 03 K	23.93 €	6.0	6(R0,5)x6x12x50	C634 0600 05 K	35.52 €
2.0	2(R0,5)x4x4x50	C634 0200 05 K	23.93 €	6.0	6(R1,1)x6x12x50	C634 0600 10 K	35.52 €
2,5	2,5(R0,2)x4x5x50	C634 0250 02 K	23.93 €	8.0	8(R0,5)x8x16x60	C634 0800 05 K	43.30 €
2,5	2,5(R0,3)x4x5x50	C634 0250 03 K	23.93 €	8.0	8(R1,1)x8x16x60	C634 0800 10 K	43.30 €
2,5	2,5(R0,5)x4x5x50	C634 0250 05 K	23.93 €	8.0	8(R1,5)x8x16x60	C634 0800 15 K	45.43 €
3.0	3(R0,2)x4x6x50	C634 0300 02 K	23.93 €	8.0	8(R2)x8x16x60	C634 0800 20 K	45.43 €
3.0	3(R0,3)x4x6x50	C634 0300 03 K	23.93 €	8.0	8(R2,5)x8x16x60	C634 0800 25 K	45.43 €
3.0	3(R0,5)x4x6x50	C634 0300 05 K	23.93 €	10.0	10(R0,5)x10x20x75	C634 1000 05 K	65.98 €
3.0	3(R1,4)x6x50	C634 0300 10 K	23.93 €	10.0	10(R1,1)x10x20x75	C634 1000 10 K	65.98 €
4.0	4(R0,2)x4x8x50	C634 0400 02 K	23.93 €	10.0	10(R1,5)x10x20x75	C634 1000 15 K	69.17 €
4.0	4(R0,3)x4x8x50	C634 0400 03 K	23.93 €	10.0	10(R2)x10x20x75	C634 1000 20 K	69.17 €
4.0	4(R0,5)x4x8x50	C634 0400 05 K	23.93 €	10.0	10(R2,5)x10x20x75	C634 1000 25 K	69.17 €
4.0	4(R1,1)x4x8x50	C634 0400 10 K	23.93 €	12.0	12(R0,5)x12x24x75	C634 1200 05 K	92.39 €
5.0	5(R0,2)x6x10x50	C634 0500 02 K	35.52 €	12.0	12(R1,1)x12x24x75	C634 1200 10 K	92.39 €
5.0	5(R0,3)x6x10x50	C634 0500 03 K	35.52 €	12.0	12(R1,5)x12x24x75	C634 1200 15 K	96.91 €
5.0	5(R0,5)x6x10x50	C634 0500 05 K	35.52 €	12.0	12(R2)x12x24x75	C634 1200 20 K	96.91 €
5.0	5(R1,1)x6x10x50	C634 0500 10 K	35.52 €	12.0	12(R2,5)x12x24x75	C634 1200 25 K	96.91 €
6.0	6(R0,2)x6x12x50	C634 0600 02 K	35.52 €				

tolérance fraises (mm)	tolérance Ø queue
0--0.03	h6

FRAISES CARBURE 4 DENTS TORIQUES CYLINDRIQUES SÉRIE NORMALE REVÊTUES TiAIN DIN 6535 HA



réf. C636K

conditions de coupe recommandées p. 99

Ø fraise	Dimensions	Réf.	Prix unitaire TARIF H.T.	Ø fraise	Dimensions	Réf.	Prix unitaire TARIF H.T.
2.0	2(R0,2)x4x4x50	C636 0200 02 K	23.93 €	6.0	6(R0,3)x6x12x50	C636 0600 03 K	35.52 €
2.0	2(R0,3)x4x4x50	C636 0200 03 K	23.93 €	6.0	6(R0,5)x6x12x50	C636 0600 05 K	35.52 €
2.0	2(R0,5)x4x4x50	C636 0200 05 K	23.93 €	6.0	6(R1)x6x12x50	C636 0600 10 K	35.52 €
2.5	2.5(R0,2)x4x5x50	C636 0250 02 K	23.93 €	8.0	8(R0,5)x8x16x60	C636 0800 05 K	43.30 €
2.5	2.5(R0,3)x4x5x50	C636 0250 03 K	23.93 €	8.0	8(R1)x8x16x60	C636 0800 10 K	43.30 €
2.5	2.5(R0,5)x4x5x50	C636 0250 05 K	23.93 €	8.0	8(R1,5)x8x16x60	C636 0800 15 K	45.43 €
3.0	3(R0,2)x4x6x50	C636 0300 02 K	23.93 €	8.0	8(R2)x8x16x60	C636 0800 20 K	45.43 €
3.0	3(R0,3)x4x6x50	C636 0300 03 K	23.93 €	8.0	8(R2,5)x8x16x60	C636 0800 25 K	45.43 €
3.0	3(R0,5)x4x6x50	C636 0300 05 K	23.93 €	10.0	10(R0,5)x10x20x75	C636 1000 05 K	65.98 €
3.0	3(R1x4)x6x50	C636 0300 10 K	23.93 €	10.0	10(R1)x10x20x75	C636 1000 10 K	65.98 €
4.0	4(R1x4)x8x50	C636 0400 10 K	23.93 €	10.0	10(R1,5)x10x20x75	C636 1000 15 K	69.17 €
4.0	4(R0,2)x4x8x50	C636 0400 02 K	23.93 €	10.0	10(R2)x10x20x75	C636 1000 20 K	69.17 €
4.0	4(R0,3)x4x8x50	C636 0400 03 K	23.93 €	10.0	10(R2,5)x10x20x75	C636 1000 25 K	69.17 €
4.0	4(R0,5)x4x8x50	C636 0400 05 K	23.93 €	12.0	12(R0,5)x12x24x75	C636 1200 05 K	92.39 €
5.0	5(R0,2)x6x10x50	C636 0500 02 K	35.52 €	12.0	12(R1)x12x24x75	C636 1200 10 K	92.39 €
5.0	5(R0,3)x6x10x50	C636 0500 03 K	35.52 €	12.0	12(R1,5)x12x24x75	C636 1200 15 K	96.91 €
5.0	5(R0,5)x6x10x50	C636 0500 05 K	35.52 €	12.0	12(R2)x12x24x75	C636 1200 20 K	96.91 €
5.0	5(R1)x6x10x50	C636 0500 10 K	35.52 €	12.0	12(R2,5)x12x24x75	C636 1200 25 K	96.91 €
6.0	6(R0,2)x6x12x50	C636 0600 02 K	35.52 €				

tolérance fraises (mm)	tolérance Ø queue
0~-0.03	h6

FRAISES FORET CARBURE 2 DENTS MULTI-V CYLINDRIQUES REVÊTUES TiAIN



réf. C626X

conditions de coupe recommandées p. 100

Ø fraise	Dimensions	Réf.	Prix unitaire TARIF H.T.	Ø fraise	Dimensions	Réf.	Prix unitaire TARIF H.T.
3.0	3X4X6X50	C626 0300 X	60.93 €	10.0	10X12X18X70	C626 1000 X	138.96 €
4.0	4X5X8X50	C626 0400 X	62.88 €	12.0	12X12X20X70	C626 1200 X	140.02 €
5.0	5X6X10X50	C626 0500 X	70.85 €	14.0	14X14X24X80	C626 1400 X	164.82 €
6.0	6X8X12X60	C626 0600 X	78.82 €	16.0	16X16X26X80	C626 1600 X	196.86 €
8.0	8X10X16X70	C626 0800 X	111.92 €	20.0	20X20X32X100	C626 2000 X	350.40 €

tolérance fraises (mm)	tolérance Ø queue
Ø3 ~ Ø10=h9 Ø12 ~ Ø20=d9	h6

CARBURE, 2 DENTS - RAINURAGE

ref. C600, C604

Matière Usinée	Aciers carbone Aciers alliés Aciers à outils	Aciers carbone Aciers alliés Aciers à outils	Aciers carbone Aciers alliés Aciers à outils	INOX Titane allié	Fontes	Aluminium allié	Cuivre, Laiton Métaux non ferreux							
DURETÉ	~ HRc 20	HRc 20~ HRc 30	HRc 30~ HRc 40											
RESISTANCE	500 ~ 800N/mm ²	800 ~ 1000N/mm ²	1000 ~ 1300N/mm ²											
DIAMETRE	RPM	Avance	RPM	Avance	RPM	Avance	RPM	Avance	RPM	Avance	RPM	Avance	RPM	Avance
2.0	5 500	80	4 800	70	4 000	55	8 000	65	6 500	150	16 000	320	12 000	240
3.0	3 700	90	3 200	80	2 600	60	5 300	65	4 200	150	11 000	320	8 000	240
4.0	2 800	90	2 400	80	2 000	60	4 000	65	3 200	150	8 000	320	6 000	240
5.0	2 200	90	1 900	80	1 600	60	3 200	65	2 500	150	6 400	320	4 800	240
6.0	1 800	90	1 600	80	1 300	60	2 600	65	2 100	180	5 300	340	4 000	260
8.0	1 400	90	1 200	80	1 000	60	2 000	65	1 600	190	4 000	340	3 000	260
10.0	1 100	90	950	80	800	60	1 600	65	1 300	200	3 200	340	2 400	260
12.0	900	90	800	80	660	60	1 300	65	1 000	210	2 600	340	2 000	260
14.0	800	90	700	80	570	60	1 100	65	900	220	2 300	340	1 700	260
16.0	700	100	600	85	500	75	1 000	75	800	225	2 000	340	1 500	260
20.0	550	100	480	85	400	75	800	80	640	240	1 600	340	1 200	260

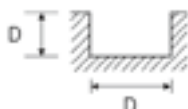

► Pour les types longs et extra-longs, l'avance peut être réduite d'environ 50%

R.P.M. = tours/minute
Avance = mm/minute

CARBURE, 2 DENTS REVÊTUES TiAIN - RAINURAGE

ref. C600K, C604X

Matière Usinée	Aciers non -alliés Aciers alliés Aciers à outils	Aciers alliés Aciers réfractaires	Aciers INOX	Fontes	Aluminium allié	Cuivre, Laiton Métaux non ferreux						
DURETÉ	~ HRc 30	HRc 30~ HRc 45										
RESISTANCE	~ 1000N/mm ²	1000 ~ 1500N/mm ²										
DIAMETRE	RPM	Avance	RPM	Avance	RPM	Avance	RPM	Avance	RPM	Avance	RPM	Avance
1.0	14 300	105	8 500	65	7 150	50	18 700	205	44 000	330	24 700	200
1.5	9 350	150	5 550	85	5 600	80	12 100	205	27 500	385	20 300	300
2.0	7 850	160	5 150	100	4 300	80	9 350	220	22 000	460	16 500	340
3.0	6 100	180	3 800	120	3 150	100	6 050	220	15 400	460	11 000	340
4.0	5 150	255	3 150	155	2 650	130	4 600	220	11 000	460	8 800	340
5.0	4 300	270	2 550	160	2 150	135	3 650	220	9 150	460	6 800	340
6.0	3 800	300	2 300	190	1 950	155	2 950	255	7 600	485	5 700	375
8.0	2 850	325	1 700	170	1 450	155	2 200	275	5 700	485	4 400	375
10.0	2 200	280	1 350	135	1 150	135	1 850	285	4 600	485	3 400	375
12.0	1 850	240	1 150	110	950	110	1 450	295	3 750	485	2 850	375
14.0	1 700	215	1 050	100	850	100	1 300	310	3 300	485	2 400	375
16.0	1 500	185	950	95	700	95	1 100	320	2 850	485	2 200	375
20.0	1 150	145	700	70	550	70	900	340	2 200	485	1 700	375

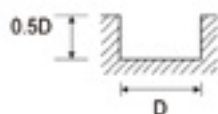

jusqu'à Ø3 : 0.2D

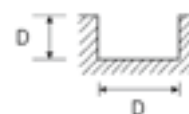

► Pour les types longs et extra-longs, l'avance peut être réduite d'environ 50%

R.P.M. = tours/minute
Avance = mm/minute

CARBURE, 3 DENTS - RAINURAGE

ref. C609

Matière Usinée	Aciers carbone Aciers alliés Aciers à outils		Aciers carbone Aciers alliés Aciers à outils		Aciers carbone Aciers alliés Aciers à outils		INOX Titane allié		Fontes		Aluminium allié		Cuivre, Laiton Métaux non ferreux	
DURETÉ	~ HRc 20		HRc 20~ HRc 30		HRc 30~ HRc 40									
RESISTANCE	500 ~ 800N/mm ²		800 ~ 1000N/mm ²		1000 ~ 1300N/mm ²									
DIAMETRE	RPM	Avance	RPM	Avance	RPM	Avance	RPM	Avance	RPM	Avance	RPM	Avance	RPM	Avance
2.0	5 500	70	4 800	60	4 000	50	8 000	55	6 500	140	16 000	290	12 000	220
3.0	3 700	80	3 200	75	2 600	55	5 300	55	4 200	140	11 000	300	8 000	220
4.0	2 800	80	2 400	75	2 000	55	4 000	55	3 200	130	8 000	290	6 000	220
5.0	2 200	80	1 900	70	1 600	55	3 200	55	2 500	135	6 400	290	4 800	220
6.0	1 800	80	1 600	70	1 300	55	2 600	60	2 100	160	5 300	305	4 000	240
8.0	1 400	80	1 200	70	1 000	55	2 000	60	1 600	170	4 000	310	3 000	230
10.0	1 100	80	950	70	800	55	1 600	60	1 300	180	3 200	305	2 400	230
12.0	900	80	800	70	660	55	1 300	60	1 000	190	2 600	300	2 000	230
14.0	800	80	700	70	570	55	1 100	60	900	200	2 300	300	1 700	230
16.0	700	90	600	75	500	65	1 000	70	800	200	2 000	300	1 500	230
20.0	550	90	480	75	400	65	800	70	640	215	1 600	300	1 200	230

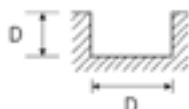

► Pour les types longs et extra-longs, l'avance peut être réduite d'environ 50%

R.P.M. = tours/minute
Avance = mm/minute

CARBURE, 3 DENTS HÉLICE 45° - RAINURAGE

ref. C611

Matière Usinée	Aciers carbone Aciers alliés Aciers à outils		Aciers carbone Aciers alliés Aciers à outils		Fontes		Aluminium allié		Cuivre, Laiton Métaux non ferreux	
DURETÉ	~ HRc 30		HRc 30~ HRc 40							
RESISTANCE	~ 1000N/mm ²		1000 ~ 1300N/mm ²							
DIAMETRE	RPM	Avance	RPM	Avance	RPM	Avance	RPM	Avance	RPM	Avance
6.0	1 600	95	1 300	65	2 100	220	5 300	410	4 000	310
8.0	1 200	95	1 000	65	1 600	230	4 000	410	3 000	310
10.0	950	95	800	65	1 300	240	3 200	410	2 400	310
12.0	800	95	660	65	1 000	250	2 600	410	2 000	310
14.0	700	95	570	65	900	260	2 300	410	1 700	310
16.0	600	100	500	80	800	270	2 000	410	1 500	310
20.0	480	100	400	80	640	290	1 600	410	1 200	310

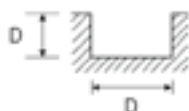

► Pour les types longs et extra-longs, l'avance peut être réduite d'environ 50%

R.P.M. = tours/minute
Avance = mm/minute

CARBURE, 3 DENTS REVÊTUE TiAlN - RAINURAGE

ref. C605K, C609K, C613K

Matière Usinée	Aciers non -alliés Aciers alliés Aciers à outils		Aciers alliés Aciers réfractaires		Aciers INOX		Fontes		Aluminium allié		Cuivre, Laiton Métaux non ferreux	
DURETÉ	~ HRc 30		HRc 30~ HRc 45									
RESISTANCE	~ 1000N/mm ²		1000 ~ 1500N/mm ²									
DIAMETRE	RPM	Avance	RPM	Avance	RPM	Avance	RPM	Avance	RPM	Avance	RPM	Avance
1.0	14 300	75	8 500	45	7 150	35	18 700	185	44 000	300	24 700	180
1.5	12 750	105	5 550	60	5 600	55	12 100	185	27 500	345	20 300	270
2.0	7 850	110	5 150	70	4 300	55	9 350	200	22 000	420	16 500	310
3.0	6 100	125	3 800	85	3 150	70	6 050	200	15 400	430	11 000	310
4.0	5 150	180	3 150	110	2 650	90	4 600	185	11 000	420	8 800	310
5.0	4 300	190	2 550	110	2 150	95	3 650	200	9 150	420	6 800	310
6.0	3 800	210	2 300	135	1 950	110	2 950	230	7 600	440	5 700	340
8.0	2 850	230	1 700	120	1 450	110	2 200	240	5 700	440	4 400	330
10.0	2 200	195	1 350	95	1 150	95	1 850	255	4 600	440	3 400	330
12.0	1 850	170	1 150	75	950	75	1 450	275	3 750	430	2 850	330
14.0	1 700	150	1 050	70	850	70	1 300	285	3 300	430	2 400	330
16.0	1 500	130	950	65	700	65	1 100	285	2 850	430	2 200	330
20.0	1 150	100	700	50	550	50	900	310	2 200	430	1 700	330



jusqu'à Ø3 : 0.2D

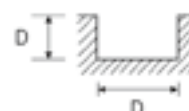

► Pour les types longs et extra-longs, l'avance peut être réduite d'environ 50%

R.P.M. = tours/minute Avance = mm/minute

CARBURE, 3 DENTS REVÊTUE TiAlN - USINAGE LATÉRAL

ref. C605K, C609K, C613K

Matière Usinée	Aciers non -alliés Aciers alliés Aciers à outils		Aciers alliés Aciers réfractaires		Aciers INOX		Fontes		Aluminium allié		Cuivre, Laiton Métaux non ferreux	
DURETÉ	~ HRc 30		HRc 30~ HRc 45									
RESISTANCE	~ 1000N/mm ²		1000 ~ 1500N/mm ²									
DIAMETRE	RPM	Avance	RPM	Avance	RPM	Avance	RPM	Avance	RPM	Avance	RPM	Avance
1.0	17600	110	10250	65	8650	55	18700	460	44000	750	24700	450
1.5	11800	160	7050	85	7050	90	12100	460	27500	860	20300	675
2.0	9850	180	6450	120	5350	100	9350	475	22000	1035	16500	770
3.0	7600	205	4750	130	3950	105	6050	475	15400	990	11000	760
4.0	6450	365	3950	220	3300	180	4600	485	11000	1035	8800	770
5.0	5350	385	3200	230	2700	195	3650	485	9150	1010	6800	760
6.0	4750	425	2850	265	2400	215	2950	570	7600	1100	5700	825
8.0	3550	450	2150	245	1800	225	2200	615	5700	1100	4400	825
10	2750	390	1700	195	1450	195	1850	640	4600	1100	3400	825
12	2350	330	1450	160	1150	155	1450	670	3750	1100	2850	825
14	2100	465	1300	145	1050	140	1300	705	3300	1100	2400	825
16	1850	265	1150	130	900	130	1100	725	2850	1100	2200	825
20	1450	205	900	100	700	100	900	770	2200	1100	1700	825



► Pour les types longs et extra-longs, l'avance peut être réduite d'environ 50%

R.P.M. = tours/minute Avance = mm/minute

CARBURE, 4 DENTS - USINAGE LATÉRAL

ref. C617, C618

Matière Usinée	Aciers carbone Aciers alliés Aciers à outils		Aciers carbone Aciers alliés Aciers à outils		Aciers carbone Aciers alliés Aciers à outils		INOX Titane allié		Fontes		Aluminium allié		Cuivre, Laiton Métaux non ferreux	
DURETÉ	~ HRc 20		HRc 20~ HRc 30		HRc 30~ HRc 40									
RESISTANCE	500 ~ 800N/mm ²		800 ~ 1000N/mm ²		1000 ~ 1300N/mm ²									
DIAMETRE	RPM	Avance	RPM	Avance	RPM	Avance	RPM	Avance	RPM	Avance	RPM	Avance	RPM	Avance
2.0	5 500	240	4 800	210	4 000	160	8 000	200	6 500	450	16 000	960	12 000	720
3.0	3 700	270	3 200	240	2 600	180	5 300	200	4 200	450	11 000	960	8 000	720
4.0	2 800	270	2 400	240	2 000	180	4 000	200	3 200	450	8 000	960	6 000	720
5.0	2 200	270	1 900	240	1 600	180	3 200	200	2 500	450	6 400	960	4 800	720
6.0	1 800	270	1 600	240	1 300	180	2 600	200	2 100	540	5 300	1 020	4 000	780
8.0	1 400	270	1 200	240	1 000	180	2 000	200	1 600	570	4 000	1 020	3 000	780
10.0	1 100	270	950	240	800	180	1 600	200	1 300	600	3 200	1 020	2 400	780
12.0	900	270	800	240	660	180	1 300	200	1 000	630	2 600	1 020	2 000	780
14.0	800	270	700	240	570	180	1 100	200	900	660	2 300	1 020	1 700	780
16.0	700	300	600	260	500	220	1 000	225	800	680	2 000	1 020	1 500	780
20.0	550	300	480	260	400	220	800	240	640	720	1 600	1 020	1 200	780



► Pour les types longs et extra-longs, l'avance peut être réduite d'environ 50%

R.P.M. = tours/minute
Avance = mm/minute

CARBURE, 4 DENTS REVÊTUE TiAlN - USINAGE LATÉRAL

ref. C617K, C618X

Matière Usinée	Aciers non -alliés Aciers alliés Aciers à outils		Aciers alliés Aciers réfractaires		Aciers INOX		Fontes		Aluminium allié		Cuivre, Laiton Métaux non ferreux	
DURETÉ	~ HRc 30		HRc 30~ HRc 45									
RESISTANCE	~ 1000N/mm ²		1000 ~ 1500N/mm ²									
DIAMETRE	RPM	Avance	RPM	Avance	RPM	Avance	RPM	Avance	RPM	Avance	RPM	Avance
1.0	17 600	150	10 250	85	8 650	75	18 700	620	44 000	1 050	24 700	605
1.5	11 800	215	7 050	115	7 050	120	12 100	620	27 500	1 160	20 300	910
2.0	9 850	240	6 450	145	5 350	120	9 350	640	22 000	1 320	16 500	1 035
3.0	7 600	270	4 750	170	3 950	145	6 050	640	15 400	1 320	11 000	1 035
4.0	6 450	485	3 950	300	3 300	240	4 600	640	11 000	1 320	8 800	1 035
5.0	5 350	510	3 200	305	2 700	255	3 650	640	9 150	1 320	6 800	1 035
6.0	4 750	560	2 850	350	2 400	280	2 950	770	7 600	1 430	5 700	1 100
8.0	3 550	605	2 150	325	1 800	300	2 200	815	5 700	1 430	4 400	1 100
10.0	2 750	520	1 700	255	1 450	255	1 850	860	4 600	1 430	3 400	1 100
12.0	2 350	440	1 450	215	1 150	205	1 450	900	3 750	1 430	2 850	1 100
14.0	2 100	395	1 300	195	1 050	190	1 300	945	3 300	1 430	2 400	1 100
16.0	1 850	350	1 150	170	950	170	1 100	970	2 850	1 430	2 200	1 100
20.0	1 450	270	900	135	700	130	900	1 035	2 200	1 430	1 700	1 100



► Pour les types longs et extra-longs, l'avance peut être réduite d'environ 50%

R.P.M. = tours/minute
Avance = mm/minute

CARBURE, MULTI DENTS ÉBAUCHE REVÊTUE TiAlN - USINAGE LATÉRAL

ref. C631K

Matière Usinée	Aciers non -alliés Aciers alliés Aciers à outils		Aciers alliés Aciers réfractaires		Aciers INOX		Inconel	
DURETÉ	~ HRc 30		HRc 30~ HRc 38		HRc 38~ HRc 45			
RESISTANCE	~ 1000N/mm ²		1000 ~ 1200N/mm ²		1200 ~ 1400N/mm ²			
DIAMETRE	RPM	Avance	RPM	Avance	RPM	Avance	RPM	Avance
6.0	13 250	1 970	10 550	710	7 150	480	2 050	160
8.0	9 850	1 970	7 800	710	5 350	480	1 550	150
10.0	7 800	1 970	6 450	710	4 350	480	1 100	160
12.0	6 800	2 040	5 100	680	3 550	480	1 000	160
14.0	5 800	2 040	4 400	710	3 050	480	750	110
16.0	5 100	2 040	4 100	650	2 800	430	700	90
18.0	4 400	1 970	3 750	610	2 300	360	600	90
20.0	4 100	1 840	3 050	480	2 050	310	550	90
25.0	3 650	1 830	2 700	530	1 850	350	500	90



► Pour les types longs et extra-longs, l'avance peut être réduite d'environ 50%

R.P.M. = tours/minute
Avance = mm/minute

CARBURE, HÉMISPHERIQUE 2 DENTS REVÊTUE TiAlN

ref. C630K, C623K

Matière Usinée	Aciers carbone Aciers alliés Aciers à outils		Aciers carbone Aciers alliés Aciers à outils		Aciers trempés		Fontes		Aluminium allié	
DURETÉ	~ HRc 30		HRc 30~ HRc 45		HRc 45~ HRc 50					
RESISTANCE	~ 1000N/mm ²		1000 ~ 1500N/mm ²		~ 1500N/mm ²					
DIAMETRE	RPM	Avance	RPM	Avance	RPM	Avance	RPM	Avance	RPM	Avance
2.0	12 350	640	9 150	415	4 000	125	10 500	220	30 800	395
3.0	11 400	575	8 550	390	3 800	125	7 050	230	20 500	395
4.0	8 950	630	7 150	450	3 600	150	5 150	285	15 400	395
5.0	7 800	700	6 200	490	3 100	150	4 150	330	12 100	470
6.0	7 250	870	5 900	705	2 700	160	3 400	360	10 300	470
8.0	6 100	1 090	4 900	785	2 050	190	2 500	460	7 900	540
10.0	5 450	1 330	4 350	870	1 750	190	2 050	460	6 150	540
12.0	4 990	1 500	3 950	950	1 500	210	1 750	460	5 150	630
14.0	4 530	1 495	3 600	925	1 300	210	1 400	460	4 300	630
16.0	4 085	1 470	3 200	905	1 150	210	1 300	460	3 850	540
18.0	3 800	1 425	3 000	890	1 050	210	1 100	460	3 400	540
20.0	3 550	1 425	2 800	885	950	210	1 050	420	2 950	540

ap : D1~D6=0.2mm
D8~D20=0.3mm
ae : 0.2D

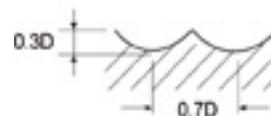
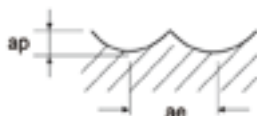

► Pour les types longs et extra-longs, l'avance peut être réduite d'environ 50%

R.P.M. = tours/minute
Avance = mm/minute

CARBURE, 2 DENTS REVÊTUE TiAlN - USINAGE DE NERVURE

ref. C632K

Matière Usinée	Aciers non -alliés Aciers alliés			Aciers alliés Aciers réfractaires		
DURETÉ	~ HRc 30			HRc 30~ HRc 45		
RESISTANCE	~ 1000N/mm ²			1000 ~ 1500N/mm ²		
DIAMETRE	RPM	Avance	ap (mm)	RPM	Avance	ap (mm)
0.4	26500~34000	170~370	0.007~0.018	19000~24000	72~290	0.007~0.018
0.5	26500~34000	170~370	0.009~0.022	19000~24000	72~290	0.009~0.022
0.6	26500~34000	210~485	0.011~0.026	19000~24000	95~365	0.011~0.026
0.7	26500~34000	210~485	0.012~0.031	19000~24000	95~365	0.012~0.031
0.8	23000~30000	240~535	0.014~0.035	16500~21000	100~410	0.014~0.035
0.9	21500~27000	240~610	0.030~0.060	15000~19000	135~460	0.030~0.060
1.0	19000~24000	240~690	0.045~0.090	13500~17000	160~510	0.045~0.090
1.2	15500~19000	240~765	0.055~0.100	11000~14000	160~510	0.055~0.100
1.4	13600~17000	240~765	0.062~0.125	9800~12000	160~510	0.062~0.125
1.5	12500~15500	240~765	0.070~0.135	8950~11500	160~510	0.070~0.135
1.6	12000~15000	240~765	0.075~0.145	8700~10900	160~510	0.075~0.145
1.8	11000~14000	240~765	0.080~0.160	7800~9800	160~510	0.080~0.160
2.0	10000~12500	240~765	0.090~0.180	7000~8950	160~510	0.090~0.180
2.5	8000~10000	240~765	0.112~0.235	5700~7200	160~510	0.112~0.235
3.0	6800~8500	240~765	0.135~0.270	4700~6000	160~510	0.135~0.270
4.0	5100~6500	240~765	0.180~0.360	3500~4500	160~510	0.180~0.360

(Profondeur de coupe par passe)



► Pour les types longs et extra-longs, l'avance peut être réduite d'environ 50%

R.P.M. = tours/minute
Avance = mm/minute

CARBURE, HÉMISPHERIQUE 2 DENTS REVÊTUE TiAlN - USINAGE DE NERVURE

ref. C633K

Matière Usinée	Aciers non -alliés Aciers alliés			Aciers alliés Aciers réfractaires		
DURETÉ	~ HRc 30			HRc 30~ HRc 45		
RESISTANCE	~ 1000N/mm ²			1000 ~ 1500N/mm ²		
DIAMETRE	RPM	Avance	ap (mm)	RPM	Avance	ap (mm)
0.4	26350~34000	150~415	0.018~0.036	19100~24200	75~230	0.018~0.036
0.5	26350~34000	150~415	0.023~0.045	19100~24200	75~230	0.023~0.045
0.6	26350~34000	190~535	0.027~0.054	19100~24200	95~300	0.027~0.054
0.8	26350~34000	190~535	0.036~0.072	19100~24200	95~300	0.036~0.072
1.0	24650~31000	210~595	0.045~0.090	17400~22100	105~330	0.045~0.090
1.2	20500~26000	210~665	0.055~0.100	14500~18300	105~330	0.055~0.100
1.4	18000~22000	210~665	0.062~0.125	12800~15300	105~330	0.062~0.125
1.5	16000~20500	210~665	0.070~0.135	11500~14900	105~330	0.070~0.135
1.6	15500~20000	210~665	0.075~0.145	11200~14000	105~330	0.075~0.145
1.8	14500~18200	210~665	0.080~0.160	10200~12800	105~330	0.080~0.160
2.0	13000~16000	210~665	0.090~0.180	9400~11500	105~330	0.090~0.180
3.0	9000~11000	210~665	0.135~0.270	6000~11500	105~330	0.135~0.270
4.0	7200~9350	210~665	0.180~0.360	5000~6600	105~330	0.180~0.360

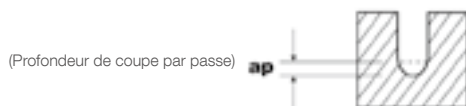

► Pour les types longs et extra-longs, l'avance peut être réduite d'environ 50%

R.P.M. = tours/minute Avance = mm/minute

CARBURE, TORIQUES 2 DENTS REVÊTUE TiAlN - FINITION DE RAINURE

ref. C634K

Matière Usinée	Aciers non -alliés Aciers alliés Aciers à outils		Aciers alliés Aciers réfractaires		Aciers INOX		Fontes		Aluminium allié		Cuivre, Laiton Métaux non ferreux	
DURETÉ	~ HRc 30		HRc 30~ HRc 45									
RESISTANCE	~ 1000N/mm ²		1000 ~ 1500N/mm ²									
DIAMETRE	RPM	Avance	RPM	Avance	RPM	Avance	RPM	Avance	RPM	Avance	RPM	Avance
2.0	7850	160	5150	100	4300	80	9350	220	22000	460	16500	340
3.0	6100	180	3800	120	3150	100	6050	220	15400	460	11000	340
4.0	5150	255	3150	155	2650	130	4600	220	11000	460	8800	340
5.0	4300	270	2550	160	2150	135	3650	220	9150	460	6800	340
6.0	3800	300	2300	190	1950	155	2950	255	7600	485	5700	375
8.0	2850	325	1700	170	1450	155	2200	275	5700	485	4400	375
10.0	2200	280	1350	135	1150	135	1850	285	4600	485	3400	375
12.0	1850	240	1150	110	950	110	1450	295	3750	485	2850	375

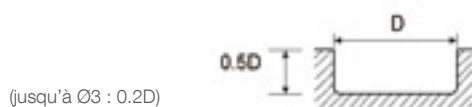

► Pour les types longs et extra-longs, l'avance peut être réduite d'environ 50%

R.P.M. = tours/minute Avance = mm/minute

CARBURE, TORIQUES 4 DENTS REVÊTUE TiAlN - USINAGE LATÉRAL

ref. C636K

Matière Usinée	Aciers non -alliés Aciers alliés Aciers à outils		Aciers alliés Aciers réfractaires		Aciers INOX		Fontes		Aluminium allié		Cuivre, Laiton Métaux non ferreux	
DURETÉ	~ HRc 30		HRc 30~ HRc 45									
RESISTANCE	~ 1000N/mm ²		1000 ~ 1500N/mm ²									
DIAMETRE	RPM	Avance	RPM	Avance	RPM	Avance	RPM	Avance	RPM	Avance	RPM	Avance
1.0	17600	150	10250	85	8650	75	18700	620	44000	1050	24700	605
1.5	11800	215	7050	115	7050	120	12100	620	27500	1160	20300	910
2.0	9850	240	6450	145	5350	120	9350	640	22000	1320	16500	1035
3.0	7600	270	4750	170	3950	145	6050	640	15400	1320	11000	1035
4.0	6450	485	3950	300	3300	240	4600	640	11000	1320	8800	1035
5.0	5350	510	3200	305	2700	255	3650	640	9150	1320	6800	1035
6.0	4750	560	2850	350	2400	280	2950	770	7600	1430	5700	1100
8.0	3550	605	2150	325	1800	300	2200	815	5700	1430	4400	1100
10.0	2750	520	1700	255	1450	255	1850	860	4600	1430	3400	1100
12.0	2350	440	1450	215	1150	205	1450	900	3750	1430	2850	1100

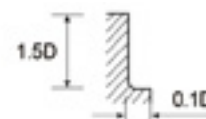

► Pour les types longs et extra-longs, l'avance peut être réduite d'environ 50%

R.P.M. = tours/minute Avance = mm/minute

CARBURE, 2 DENTS REVÊTUE TiAIN - CHANFREINAGE

ref. C626X

Matière Usinée	Aciers carbone Aciers alliés Aciers à outils		Aciers carbone Aciers alliés Aciers à outils		Aciers carbone Aciers alliés Aciers à outils		Acier INOX Alliages de Titane		Aluminium allié		
	DURETÉ	~ HRC 20	HRC 20~ HRC 30	HRC 30 ~ HRC 40	DURETÉ	~ HRC 20	HRC 20~ HRC 30	HRC 30 ~ HRC 40	RESISTANCE	500 ~ 800N/mm ²	800 ~ 1000N/mm ²
DIAMETRE	RPM	Avance	RPM	Avance	RPM	Avance	RPM	Avance	RPM	Avance	
3.0	6160	310	4900	225	4200	195	3360	140	15400	770	
4.0	5040	310	4200	225	3500	195	2800	140	12600	810	
5.0	4005	320	3360	240	2800	195	2465	145	9660	870	
6.0	3220	335	2800	240	2240	195	1960	145	7840	895	
8.0	2465	350	2155	250	1680	2030	1400	155	6160	925	
10.0	2100	350	1820	265	1540	2030	1220	155	5600	950	
12.0	1820	365	1540	280	1260	210	1020	160	4900	980	
16.0	1400	350	1330	280	980	225	770	170	3850	1035	
20.0	1330	365	1050	295	840	225	740	180	3080	1080	



► Pour les types longs et extra-longs, l'avance peut être réduite d'environ 50%

R.P.M. = tours/minute Avance = mm/minute

CARBURE, 2 DENTS REVÊTUE TiAIN - CHANFREINAGE ET USINAGE LATÉRAL

ref. C626X



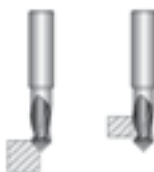





Matière Usinée	Aciers carbone Aciers alliés Aciers à outils		Aciers carbone Aciers alliés Aciers à outils		Aciers carbone Aciers alliés Aciers à outils		Acier INOX Alliages de Titane		Aluminium allié		
	DURETÉ	~ HRC 20	HRC 20~ HRC 30	HRC 30 ~ HRC 40	DURETÉ	~ HRC 20	HRC 20~ HRC 30	HRC 30 ~ HRC 40	RESISTANCE	500 ~ 800N/mm ²	800 ~ 1000N/mm ²
DIAMETRE	RPM	Avance	RPM	Avance	RPM	Avance	RPM	Avance	RPM	Avance	
3.0	5900	95	3900	65	3300	50	2400	40	14000	230	
4.0	4800	95	3200	65	2800	50	2000	40	12000	240	
5.0	3800	100	2500	65	2200	55	1760	45	9500	250	
6.0	3000	110	2000	70	1800	60	1400	50	7700	300	
8.0	2300	115	1540	75	1300	65	1100	55	5800	350	
10.0	2000	120	1300	80	1200	65	1000	55	5100	380	
12.0	1760	130	1100	90	1000	70	840	60	4400	400	
16.0	1300	140	900	90	770	70	660	60	3300	330	
20.0	1100	140	700	90	600	70	440	60	2640	340	



► Pour les types longs et extra-longs, l'avance peut être réduite d'environ 50%

R.P.M. = tours/minute Avance = mm/minute

FRAISES HSS-PM FRITTE

			LISTE DES MATIÈRES									
			aciers jusqu'à HB325	aciers jusqu'à 40HRc	aciers jusqu'à 45HRc	aciers INOX	fontes	Cuivre	Titane	Inconel	ALU	plastiques
C651	Fraises HSS-PM 2 dents à méplat série normale revêtues AlCrN		p. 102	●	●	●	●	●				
C653	Fraises HSS-PM 3 dents à méplat série normale revêtues AlCrN		p. 102	●	●	●	●	●				
C654	Fraises HSS-PM 4 dents à méplat série normale revêtues AlCrN		p. 103	●	●	●	●	●				
C655	Fraises HSS-PM 4 dents à méplat série longue revêtues AlCrN		p. 103	●	●	●	●	●				
C656	Fraises HSS-PM 2 dents hémisphériques série normale revêtues AlCrN		p. 104	●	●	●	●	●				
C657	Fraises HSS-PM 2 dents hémisphériques série longue revêtues AlCrN		p. 104	●	●	●	●	●				
C660	Fraises HSS-PM multi-dents ébauche pas fins hélice 45° série normale revêtues AlCrN		p. 105	●	●	●	●	●				
C659	Fraises HSS-PM multi-dents ébauche pas fins série longue revêtues AlCrN		p. 105	●	●	●	●	●				

● utilisation conseillée pour la matière concernée.

DONNÉES TECHNIQUES

Conditions de coupe recommandées

pages 106 à 108

FRAISES HSS-PM 2 DENTS À MÉPLAT SÉRIE NORMALE REVÊTUES AICrN DIN 844

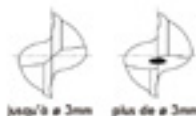

réf. C651

conditions de coupe recommandées p. 106

Ø fraiseage	Dimensions	Réf.	Prix unitaire TARIF H.T.	Ø fraiseage	Dimensions	Réf.	Prix unitaire TARIF H.T.
1.0	1X6X3X47	C651 0100 KM	26.63 €	10.0	10X10X22X72	C651 1000 KM	37.69 €
2.0	2X6X7X51	C651 0200 KM	24.19 €	12.0	12X12X26X83	C651 1200 KM	50.09 €
3.0	3X6X8X52	C651 0300 KM	24.19 €	14.0	14X12X26X83	C651 1400 KM	55.82 €
4.0	4X6X11X55	C651 0400 KM	24.19 €	16.0	16X16X32X92	C651 1600 KM	66.24 €
5.0	5X6X13X57	C651 0500 KM	24.19 €	18.0	18X16X32X92	C651 1800 KM	82.89 €
6.0	6X6X13X57	C651 0600 KM	24.19 €	20.0	20X20X38X104	C651 2000 KM	107.82 €
7.0	7X10X16X66	C651 0700 KM	36.43 €	22.0	22X20X38X104	C651 2200 KM	119.48 €
8.0	8X10X19X69	C651 0800 KM	36.43 €	25.0	25X25X45X121	C651 2500 KM	159.55 €
9.0	9X10X19X69	C651 0900 KM	37.69 €				

Tolérances selon DIN 7160 & 7161

Plage de tolérance en µm					
Diamètre nominal en mm					
	de 1 à 3	plus de 3 à 6	plus de 6 à 10	plus de 10 à 18	plus de 18 à 30
e8	- 14 - 28	- 20 - 38	- 25 - 47	- 32 - 59	- 40 - 73
h6	0 - 6	0 - 8	0 - 9	0 - 11	0 - 13

FRAISES HSS-PM 3 DENTS À MÉPLAT SÉRIE NORMALE REVÊTUES AICrN DIN 844



réf. C653

conditions de coupe recommandées p. 107

Ø fraiseage	Dimensions	Réf.	Prix unitaire TARIF H.T.	Ø fraiseage	Dimensions	Réf.	Prix unitaire TARIF H.T.
1	1X6X3X47	C653 0100 KM	26.63 €	10	10X10X22X72	C653 1000 KM	37.69 €
2	2X6X7X51	C653 0200 KM	24.19 €	12	12X12X26X83	C653 1200 KM	50.09 €
3	3X6X8X52	C653 0300 KM	24.19 €	14	14X12X26X83	C653 1400 KM	55.82 €
4	4X6X11X55	C653 0400 KM	24.19 €	16	16X16X32X92	C653 1600 KM	66.24 €
5	5X6X13X57	C653 0500 KM	24.19 €	18	18X16X32X92	C653 1800 KM	82.89 €
6	6X6X13X57	C653 0600 KM	24.19 €	20	20X20X38X104	C653 2000 KM	107.82 €
7	7X10X16X66	C653 0700 KM	36.43 €	22	22X20X38X104	C653 2200 KM	119.48 €
8	8X10X19X69	C653 0800 KM	36.43 €	25	25X25X45X121	C653 2500 KM	158.44 €
9	9X10X19X69	C653 0900 KM	37.69 €				

Tolérances selon DIN 7160 & 7161

Plage de tolérance en µm					
Diamètre nominal en mm					
	de 1 à 3	plus de 3 à 6	plus de 6 à 10	plus de 10 à 18	plus de 18 à 30
e8	- 14 - 28	- 20 - 38	- 25 - 47	- 32 - 59	- 40 - 73
h6	0 - 6	0 - 8	0 - 9	0 - 11	0 - 13

FRAISES HSS-PM 4 DENTS À MÉPLAT SÉRIE NORMALE REVÊTUES AICrN DIN 844



réf. C654

conditions de coupe recommandées p. 108

Ø fraissage	Dimensions	Réf.	Prix unitaire TARIF H.T.	Ø fraissage	Dimensions	Réf.	Prix unitaire TARIF H.T.
1	1X6X3X49	C654 0100 KM	26.63 €	10	10X10X22X72	C654 1000 KM	37.69 €
2	2X6X7X51	C654 0200 KM	24.19 €	12	12X12X26X83	C654 1200 KM	50.09 €
3	3X6X8X52	C654 0300 KM	24.19 €	14	14X12X26X83	C654 1400 KM	55.82 €
4	4X6X11X55	C654 0400 KM	24.19 €	16	16X16X32X92	C654 1600 KM	66.24 €
5	5X6X13X57	C654 0500 KM	24.19 €	18	18X16X32X92	C654 1800 KM	82.89 €
6	6X6X13X57	C654 0600 KM	24.19 €	20	20X20X38X104	C654 2000 KM	107.82 €
7	7X10X16X66	C654 0700 KM	36.43 €	22	22X20X38X104	C654 2200 KM	119.48 €
8	8X10X19X69	C654 0800 KM	36.43 €	25	25X25X45X121	C654 2500 KM	159.55 €
9	9X10X19X69	C654 0900 KM	37.69 €				

tolérance fraises (mm)	tolérance Ø queue
0~+0.03	h6

FRAISES HSS-PM 4 DENTS À MÉPLAT SÉRIE LONGUE REVÊTUES AICrN DIN 844 L



réf. C655

conditions de coupe recommandées p. 108

Ø fraissage	Dimensions	Réf.	Prix unitaire TARIF H.T.	Ø fraissage	Dimensions	Réf.	Prix unitaire TARIF H.T.
2	2X6X10X54	C655 0200 KM	29.66 €	10	10X10X45X95	C655 1000 KM	47.11 €
3	3X6X12X56	C655 0300 KM	29.66 €	12	12X12X53X110	C655 1200 KM	65.52 €
4	4X6X19X63	C655 0400 KM	29.66 €	14	14X12X53X110	C655 1400 KM	73.75 €
5	5X6X24X68	C655 0500 KM	29.66 €	16	16X16X63X123	C655 1600 KM	90.49 €
6	6X6X24X68	C655 0600 KM	29.66 €	18	18X16X63X123	C655 1800 KM	115.13 €
7	7X10X30X80	C655 0700 KM	46.79 €	20	20X20X75X141	C655 2000 KM	150.31 €
8	8X10X38X88	C655 0800 KM	46.79 €	22	22X20X75X141	C655 2200 KM	164.10 €
9	9X10X38X88	C655 0900 KM	47.11 €	25	25X25X90X166	C655 2500 KM	243.17 €

tolérance fraises (mm)	tolérance Ø queue
0~+0.03	h6

FRAISES HSS-PM 2 DENTS HÉMISPHERIQUES SÉRIE NORMALE REVÊTUES AICrN DIN 327



réf. C656

conditions de coupe recommandées p. 108

Ø fraissage	Dimensions	Réf.	Prix unitaire TARIF H.T.	Ø fraissage	Dimensions	Réf.	Prix unitaire TARIF H.T.
1	1X6X2,5X47	C656 0100 KM	30.58 €	10	10X10X13X63	C656 1000 KM	40.85 €
2	2X6X4X48	C656 0200 KM	27.81 €	12	12X12X16X73	C656 1200 KM	52.13 €
3	3X6X5X49	C656 0300 KM	27.81 €	14	14X12X16X73	C656 1400 KM	57.73 €
4	4X6X7X51	C656 0400 KM	27.81 €	16	16X16X19X79	C656 1600 KM	67.42 €
5	5X6X8X52	C656 0500 KM	27.81 €	18	18X16X19X79	C656 1800 KM	104.06 €
6	6X6X8X52	C656 0600 KM	27.81 €	20	20X20X22X88	C656 2000 KM	106.37 €
7	7X10X10X60	C656 0700 KM	39.73 €	22	22X20X22X88	C656 2200 KM	122.11 €
8	8X10X11X61	C656 0800 KM	39.73 €	25	25X25X26X102	C656 2500 KM	154.73 €
9	9X10X11X61	C656 0900 KM	40.85 €				

tolérance fraises (mm)	tolérance Ø queue
0--0.03	h6

FRAISES HSS-PM 2 DENTS HÉMISPHERIQUES SÉRIE LONGUE REVÊTUES AICrN DIN 1889



réf. C657

conditions de coupe recommandées p. 108

Ø fraissage	Dimensions	Réf.	Prix unitaire TARIF H.T.	Ø fraissage	Dimensions	Réf.	Prix unitaire TARIF H.T.
2	2X6X7X54	C657 0200 KM	33.08 €	10	10X10X22X95	C657 1000 KM	48.97 €
3	3X6X8X56	C657 0300 KM	33.08 €	12	12X12X26X110	C657 1200 KM	65.52 €
4	4X6X11X63	C657 0400 KM	33.08 €	14	14X12X26X110	C657 1400 KM	74.40 €
5	5X6X13X68	C657 0500 KM	33.08 €	16	16X16X32X123	C657 1600 KM	88.71 €
6	6X6X13X68	C657 0600 KM	33.08 €	18	18X16X32X123	C657 1800 KM	112.96 €
7	7X10X16X80	C657 0700 KM	47.45 €	20	20X20X38X141	C657 2000 KM	144.86 €
8	8X10X19X88	C657 0800 KM	47.45 €	22	22X20X38X141	C657 2200 KM	161.72 €
9	9X10X19X88	C657 0900 KM	48.97 €	25	25X25X45X166	C657 2500 KM	232.24 €

tolérance fraises (mm)	tolérance Ø queue
0--0.03	h6

FRAISES HSS-PM MULTI-DENTS ÉBAUCHE PAS FINS HÉLICE 45° SÉRIE NORMALE REVÊTUES AICrN DIN 844



réf. C660

conditions de coupe recommandées p. 106

Ø fraissage	Dimensions	Réf.	Prix unitaire TARIF H.T.
3 dents			
4	4x6x11x57	C660 0400 KM	41.99 €
4 dents			
5	5x6x13x57	C660 0500 KM	41.99 €
6	6x6x13x57	C660 0600 KM	41.99 €
7	7X10X16X66	C660 0700 KM	56.16 €
8	8x10x19x69	C660 0800 KM	56.16 €
9	9x10x19x69	C660 0900 KM	57.62 €
10	10x10x22(31)x72	C660 1000 KM	57.62 €
12	12x12x26(37)x83	C660 1200 KM	70.40 €
5 dents			
14	14x12x26x83	C660 1400 KM	84.21 €
16	16X16X32(44)X92	C660 1600 KM	97.13 €
6 dents			
18	18x16x32x92	C660 1800 KM	105.18 €
20	20X20x38(54)x104	C660 2000 KM	134.43 €
25	25X25X45(63)X121	C660 2500 KM	197.84 €

Tolérances selon DIN 7160 & 7161

Plage de tolérance en µm			
Diamètre nominal en mm			
	de 1 à 3	plus de 3 à 6	plus de 6 à 10
js12	± 50	± 60	± 75
h6	0 - 6	0 - 8	0 - 9
Plage de tolérance en µm			
Diamètre nominal en mm			
	plus de 10 à 18	de 18 à 30	plus de 30 à 50
js12	± 90	± 105	± 125
h6	0 - 11	0 - 13	0 - 16

FRAISES HSS-PM MULTI-DENTS ÉBAUCHE PAS FINS SÉRIE LONGUE REVÊTUES AICrN DIN 844 L



réf. C659

conditions de coupe recommandées p. 106

Ø fraissage	Dimensions	Réf.	Prix unitaire TARIF H.T.
3 dents			
6	6X6X24X68	C659 0600 KM	56.28 €
7	7X10X30X80	C659 0700 KM	68.67 €
8	8X10X38X88	C659 0800 KM	68.67 €
9	9X10X38X88	C659 0900 KM	69.06 €
4 dents			
10	10X10X45X95	C659 1000 KM	69.06 €
12	12X12X53X110	C659 1200 KM	84.35 €
14	14X12X53X110	C659 1400 KM	111.55 €
16	16X16X63X123	C659 1600 KM	121.39 €
18	18X16X63X123	C659 1800 KM	145.58 €
20	20X20X75X141	C659 2000 KM	176.56 €
5 dents			
22	22X20X75X141	C659 2200 KM	231.04 €
25	25X25X90X166	C659 2500 KM	282.72 €

Tolérances selon DIN 7160 & 7161

Plage de tolérance en µm			
Diamètre nominal en mm			
	de 1 à 3	plus de 3 à 6	plus de 6 à 10
js12	± 50	± 60	± 75
h6	0 - 6	0 - 8	0 - 9
Plage de tolérance en µm			
Diamètre nominal en mm			
	plus de 10 à 18	de 18 à 30	plus de 30 à 50
js12	± 90	± 105	± 125
h6	0 - 11	0 - 13	0 - 16

HSS-PM PREMIUM, 2 DENTS REVÊTUE AICrN - RAINURAGE

ref. C651

Matière Usinée	Aciers structurels Aciers carbone		Aciers structurels Aciers carbone Fontes		Aciers carbone Aciers alliés Aciers à outil		Aciers Prétraités Aciers alliés Aciers à outil		Aciers alliés Aciers à outil Austénitique Aciers INOX	
DURETÉ			~ HRc20		HRc20 ~ HRc30		HRc30 ~ HRc35		HRc35 ~ HRc40	
RESISTANCE	~ 500N/mm ²		500 ~ 800N/mm ²		800 ~ 1000N/mm ²		1000 ~ 1100N/mm ²		1100 ~ 1300N/mm ²	
DIAMETRE	RPM	Avance	RPM	Avance	RPM	Avance	RPM	Avance	RPM	Avance
2.0	7 000	115	5 900	90	4 900	80	3 150	65	2 000	40
3.0	5 000	160	4 100	135	3 350	115	2 300	80	1 800	62
4.0	4 300	230	3 600	175	3 150	160	2 000	92	1 600	75
5.0	3 900	255	3 250	200	2 600	185	1 700	102	1 350	75
6.0	3 500	265	2 900	210	2 300	190	1 450	110	1 150	85
8.0	2 600	275	2 200	240	1 800	200	1 150	115	890	85
10.0	2 100	300	1 800	265	1 450	230	900	125	700	102
12.0	1 800	275	1 450	240	1 150	210	740	115	580	85
14.0	1 600	265	1 250	210	1 000	195	630	110	500	80
16.0	1 350	265	1 150	195	890	180	560	102	440	80
18.0	1 150	240	950	195	790	160	500	100	400	75
20.0	950	220	780	165	700	150	440	92	360	70
22.0	840	185	710	150	600	125	400	80	320	55
25.0	750	155	630	140	490	115	360	75	250	52

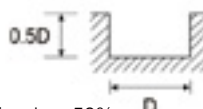

► Pour les types longs et extra-longs, l'avance peut être réduite d'environ 50%

R.P.M. = tours/minute
Avance = mm/minute

HSS-PM PREMIUM, MULTI DENTS REVÊTUE AICrN ÉBAUCHE - USINAGE LATÉRAL

ref. C659, C660

Matière Usinée	Aciers structurels Aciers carbone		Aciers structurels Aciers carbone Fontes		Aciers carbone Aciers alliés Aciers à outil		Aciers Prétraités Aciers alliés Aciers à outil		Aciers INOX	
DURETÉ			~ HRc20		HRc20 ~ HRc30		HRc35 ~ HRc40			
RESISTANCE	~ 500N/mm ²		500 ~ 800N/mm ²		800 ~ 1000N/mm ²		1100 ~ 1300N/mm ²			
DIAMETRE	RPM	Avance	RPM	Avance	RPM	Avance	RPM	Avance	RPM	Avance
6.0	2 800	230	2 200	180	1 600	115	1 300	105	1450	110
8.0	2 400	290	1 900	230	1 400	160	1 050	125	1200	140
10.0	1 900	415	1 500	315	1 050	195	890	160	950	170
12.0	1 600	415	1 200	330	900	230	740	180	800	205
14.0	1 400	415	1 050	330	760	230	630	180	690	205
16.0	1 200	415	950	330	660	230	550	180	600	205
18.0	1 050	415	890	330	610	230	490	180	550	205
20.0	960	425	760	330	530	230	440	180	480	205
22.0	890	425	650	330	470	230	400	180	430	205
25.0	790	415	600	315	420	220	360	180	390	200



► Pour les types longs et extra-longs, l'avance peut être réduite d'environ 50%

R.P.M. = tours/minute
Avance = mm/minute

HSS-PM PREMIUM, 3 DENTS REVÊTUE AICrN - RAINURAGE

ref. C653

Matière Usinée	Aciers structurels Aciers carbone		Aciers structurels Aciers carbone Fontes		Aciers carbone Aciers alliés Aciers à outil		Aciers Prétraités Aciers alliés Aciers à outil		Aciers alliés Aciers à outil Austénitique Aciers INOX	
DURETÉ			~ HRc20		HRc20 ~ HRc30		HRc30 ~ HRc35		HRc35 ~ HRc40	
RESISTANCE	~ 500N/mm ²		500 ~ 800N/mm ²		800 ~ 1000N/mm ²		1000 ~ 1100N/mm ²		1100 ~ 1300N/mm ²	
DIAMETRE	RPM	Avance	RPM	Avance	RPM	Avance	RPM	Avance	RPM	Avance
2.0	6 500	70	5 500	55	4 800	45	3 000	35	1 900	28
3.0	4 600	102	3 900	85	3 350	52	2 200	45	1 800	45
4.0	4 300	140	3 600	115	3 000	80	1 900	52	1 500	55
5.0	3 800	160	3 200	130	2 600	92	1 700	62	1 300	55
6.0	3 350	230	2 800	190	2 300	140	1 450	92	1 100	75
8.0	2 600	240	2 200	210	1 800	150	1 150	102	890	85
10.0	100	250	1 800	210	1 400	160	890	115	680	92
12.0	1 800	275	1 450	230	1 200	170	740	115	580	92
14.0	1 600	250	1 350	220	1 000	160	660	110	500	85
16.0	1 350	240	1 150	210	890	150	560	102	440	85
18.0	1 150	240	890	190	790	150	500	95	400	80
20.0	950	230	790	190	700	140	440	92	360	80
22.0	840	230	730	195	600	150	400	95	315	85
25.0	750	240	630	210	490	160	360	102	250	85

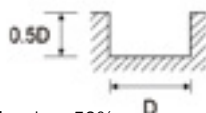

► Pour les types longs et extra-longs, l'avance peut être réduite d'environ 50%

R.P.M. = tours/minute
Avance = mm/minute

HSS-PM PREMIUM, 3 DENTS REVÊTUE AICrN - USINAGE LATÉRAL

ref. C653

Matière Usinée	Aciers structurels Aciers carbone		Aciers structurels Aciers carbone Fontes		Aciers carbone Aciers alliés Aciers à outil		Aciers Prétraités Aciers alliés Aciers à outil		Aciers alliés Aciers à outil Austénitique Aciers INOX	
DURETÉ			~ HRc20		HRc20 ~ HRc30		HRc30 ~ HRc35		HRc35 ~ HRc40	
RESISTANCE	~ 500N/mm ²		500 ~ 800N/mm ²		800 ~ 1000N/mm ²		1000 ~ 1100N/mm ²		1100 ~ 1300N/mm ²	
DIAMETRE	RPM	Avance	RPM	Avance	RPM	Avance	RPM	Avance	RPM	Avance
2.0	8 200	100	6 800	80	5 500	65	3 800	50	2 400	40
3.0	5 800	145	4 800	120	3 800	75	2 700	65	2 200	65
4.0	5 200	185	4 400	155	3 500	110	2 300	75	1 900	75
5.0	4 700	210	4 000	175	2 900	125	2 000	85	1 700	75
6.0	4 200	300	3 600	250	2 600	190	1 800	125	1 500	100
8.0	3 200	330	2 600	270	2 000	200	1 300	140	1 100	115
10.0	2 500	350	2 100	290	1 600	210	1 000	150	890	125
12.0	2 100	350	1 800	300	1 400	230	900	150	740	125
14.0	1 800	350	1 500	285	1 150	210	780	140	630	120
16.0	1 600	330	1 300	275	1 000	200	660	140	550	115
18.0	1 350	310	1 150	265	890	195	580	130	500	110
20.0	1 250	300	1 050	255	780	190	520	125	440	110
22.0	1 150	310	950	265	740	195	470	130	400	110
25.0	1 000	330	840	275	630	210	420	135	360	120



► Pour les types longs et extra-longs, l'avance peut être réduite d'environ 50%

R.P.M. = tours/minute
Avance = mm/minute

HSS-PM PREMIUM, 4 DENTS REVÊTUE AICrN - USINAGE LATÉRAL

ref. C654, C655

Matière Usinée	Aciers structurels Aciers carbone		Aciers structurels Aciers carbone Fontes		Aciers carbone Aciers alliés Aciers à outil		Aciers Prétraités Aciers alliés Aciers à outil		Aciers alliés Aciers à outil Austénitique Aciers INOX	
DURETÉ			~ HRc20		HRc20 ~ HRc30		HRc30 ~ HRc35		HRc35 ~ HRc40	
RESISTANCE	~ 500N/mm ²		500 ~ 800N/mm ²		800 ~ 1000N/mm ²		1000 ~ 1100N/mm ²		1100 ~ 1300N/mm ²	
DIAMETRE	RPM	Avance	RPM	Avance	RPM	Avance	RPM	Avance	RPM	Avance
2.0	9 200	290	8 400	240	6 100	170	4 100	125	3 300	85
3.0	6 600	410	6 000	350	4 400	250	2 700	180	2 400	125
4.0	5 300	480	4 700	400	3 600	300	2 300	200	2 000	150
5.0	4 400	510	4 000	420	2 900	320	2 000	220	1 700	160
6.0	3 900	540	3 600	450	2 600	330	1 800	230	1 450	180
8.0	3 100	570	2 600	480	2 000	370	1 400	240	1 150	185
10.0	2 300	630	2 100	530	1 600	380	1 000	265	890	200
12.0	2 000	570	1 800	480	1 400	370	890	240	720	185
14.0	1 800	550	1 600	460	1 100	350	790	230	630	170
16.0	1 600	510	1 400	430	1 000	340	680	220	550	165
18.0	1 500	460	1 250	400	890	310	630	195	500	150
20.0	1 250	440	1 050	370	780	275	530	175	440	140
22.0	1 050	410	950	320	680	255	470	160	400	130
25.0	1 000	370	840	305	630	230	420	150	360	125



► Pour les types longs et extra-longs, l'avance peut être réduite d'environ 50%

R.P.M. = tours/minute
Avance = mm/minute

HSS-PM PREMIUM, HÉMISPHERIQUE 2 DENTS REVÊTUE AICrN - PROFILAGE

ref. C656, C657



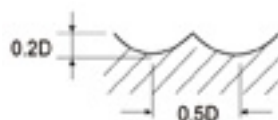





Matière Usinée	Aciers structurels Aciers carbone		Aciers structurels Aciers carbone Fontes		Aciers carbone Aciers alliés Aciers à outil		Aciers Prétraités Aciers alliés Aciers à outil		Aciers INOX	
DURETÉ			~ HRc20		HRc20 ~ HRc30		HRc35 ~ HRc40			
RESISTANCE	~ 500N/mm ²		500 ~ 800N/mm ²		800 ~ 1000N/mm ²		1100 ~ 1300N/mm ²			
DIAMETRE	RPM	Avance	RPM	Avance	RPM	Avance	RPM	Avance	RPM	Avance
R1.5 × 3.0	7 300	340	5 800	230	3 900	125	2 000	55	2200	60
R2.0 × 4.0	6 000	430	4 620	290	3 000	160	1 600	75	1760	80
R3.0 × 6.0	4 400	480	3 500	320	2 300	180	1 200	85	1320	95
R4.0 × 8.0	3 350	530	2 600	350	1 800	200	890	85	980	95
R5.0 × 10.0	2 750	600	2 100	400	1 400	230	680	102	750	110
R6.0 × 12.0	2 300	530	1 800	350	1 200	200	580	85	640	95
R8.0 × 16.0	1 700	480	1 300	320	890	180	440	80	490	90
R10.0 × 20.0	1 350	420	1 000	280	680	150	360	70	400	80
R12.5 × 25.0	950	310	740	210	470	115	250	52	275	55



► Pour les types longs et extra-longs, l'avance peut être réduite d'environ 50%

R.P.M. = tours/minute
Avance = mm/minute

FRAISES HSSCo

			LISTE DES MATIÈRES									
			aciers jusqu'à HB325	aciers jusqu'à 40HRc	aciers jusqu'à 45HRc	aciers INOX	fontes	Cuivre	Titane	Inconel	ALU	plastiques
C705	Fraises HSS-E, 1 dent courte ALUMINIUM		p. 111	●							●	
C706	Fraises HSS-E, 1 dent courte ACIER		p. 111	●							●	
C700 C700 FM	Fraises HSSCo8, 2 dents DIN 327 série courte non-revêtues et revêtues TiAIN		p. 112	●	●						●	
C701 C701 FM	Fraises HSSCo8, 2 dents DIN 844 série normale non-revêtues et revêtues TiAIN		p. 114	●	●						●	
C702 C702 FM	Fraises HSSCo8, 2 dents DIN 844 série longue non-revêtues et revêtues TiAIN		p. 115	●	●						●	
C703	Fraises HSSCo8, 2 dents DIN 844 série normale ALUMINIUM		p. 116								●	
C704	Fraises HSSCo8, 2 dents DIN 844 série longue ALUMINIUM		p. 117								●	
C710 C710 FM	Fraises HSSCo8, 3 dents extra-courtes non-revêtues et revêtues TiAIN		p. 118	●	●						●	

suite page suivante

● utilisation conseillée pour la matière concernée.

DONNÉES TECHNIQUES

Conditions de coupe recommandées

pages 128 à 133

FRAISES HSSCo

		LISTE DES MATIÈRES										
			aciers jusqu'à HB325	aciers jusqu'à 40HRc	aciers jusqu'à 45HRc	aciers INOX	fontes	Cuivre	Titane	Inconel	ALU	plastiques
C707 C707 FM	Fraises HSSCo8, 3 dents DIN 327 série courte non-revêtues et revêtues TiAIN		p. 119	●	●						●	
C708 C708 FM	Fraises HSSCo8, 3 dents DIN 844 série normale non-revêtues et revêtues TiAIN		p. 120	●	●						●	
C709 C709 FM	Fraises HSSCo8, 3 dents DIN 844 série longue non-revêtues et revêtues TiAIN		p. 121	●	●						●	
C716 C716 FM	Fraises HSSCo8, 4 et 6 dents DIN 844 série normale non-revêtues et revêtues TiAIN		p. 122	●	●						●	
C717 C717 FM	Fraises HSSCo8, 4 et 6 dents DIN 844 série longue non-revêtues et revêtues TiAIN		p. 123	●	●						●	
C719 C719 FM	Fraises HSSCo8, 2 dents hémisphérique DIN 327 série courte, non-revêtues et revêtues TiAIN		p. 124	●	●						●	
C720 C720 FM	Fraises HSSCo8 2 dents hémisphérique DIN 844 série longue, non-revêtues et revêtues TiAIN		p. 125	●	●						●	
C734 C734 FM	Fraises HSSCo8, ébauche multi-dents pas fins DIN 844 série normale, non-revêtues et revêtues TiAIN		p. 126	●	●						●	
C735 C735 FM	Fraises HSSCo8, ébauche multi-dents pas fins DIN 844 série longue non-revêtues et revêtues TiAIN		p. 127	●	●						●	

● utilisation conseillée pour la matière concernée.

DONNÉES TECHNIQUES

Conditions de coupe recommandées

pages 128 à 133

FRAISES HSS-E, 1 DENT COURTE ALUMINIUM



réf. C705

conditions de coupe recommandées p. 133

Ø fraissage	Dimensions	Réf.	Prix unitaire TARIF H.T.
3.0	3x8x12x60	C705 0300	12.57 €
4.0	4x8x12x60	C705 0400	12.57 €
5.0	5x8x14x60	C705 0500	12.57 €
6.0	6x8x14x60	C705 0600	13.55 €
7.0	7x8x14x60	C705 0700	13.55 €
8.0	8x8x14x80	C705 0800	13.55 €
9.0	9x8x14x80	C705 0900	18.45 €
10.0	10x8x14x80	C705 1000	18.45 €



conditions de coupe recommandées p. 133

Ø fraissage	Dimensions	Réf.	Prix unitaire TARIF H.T.
5.0	5x8x18-35x80	C705 5001	17.20 €
5.0	5x8x40x100	C705 5002	24.73 €
8.0	8x8x14-68x120	C705 8001	28.44 €

FRAISES HSS-E, 1 DENT COURTE ACIER



réf. C706

conditions de coupe recommandées p. 133

Ø fraissage	Dimensions	Réf.	Prix unitaire TARIF H.T.
3.0	3x8x12x60	C706 0300	12.57 €
4.0	4x8x12x60	C706 0400	12.57 €
5.0	5x8x12x60	C706 0500	12.57 €
6.0	6x8x14x60	C706 0600	13.55 €
7.0	7x8x14x60	C706 0700	13.55 €
8.0	8x8x14x80	C706 0800	13.55 €
9.0	9x8x14x80	C706 0900	18.45 €
10.0	10x8x14x80	C706 1000	18.45 €

Tolérances selon DIN 7160 & 7161

	Plage de tolérance en µm					
	Diamètre nominal en mm					
	de 1 à 3	plus de 3 à 6	plus de 6 à 10	plus de 10 à 18	de 18 à 30	plus de 30 à 50
js14	±125	±150	±180	±215	±260	±310
h6	0 - 6	0 - 8	0 - 9	0 - 11	0 - 13	0 - 16

FRAISES HSSCo8, 2 DENTS DIN 327 SÉRIE COURTE



réf. C700

conditions de coupe recommandées p.128

Ø fraisage	Dimensions	Réf.		Prix unitaire TARIF H.T.	Réf.	
		non-revêtues			revêtues TiAlN	Prix unitaire TARIF H.T.
1.0	1x6x2.5x47	C700 0100 M		12.23 €	C700 0100 FM	15.69 €
1.5	1.5x6x3x47	C700 0150 M		11.59 €	C700 0150 FM	15.08 €
2.0	2x6x4x48	C700 0200 M		10.14 €	C700 0200 FM	13.60 €
2.5	2.5x6x5x49	C700 0250 M		10.14 €	C700 0250 FM	13.60 €
2.8	2.8x6x5x49	C700 0280 M		10.14 €	C700 0280 FM	13.60 €
3.0	3x6x5x49	C700 0300 M		10.14 €	C700 0300 FM	13.60 €
3.5	3.5x6x6x50	C700 0350 M		10.14 €	C700 0350 FM	13.60 €
3.8	3.8x6x7x51	C700 0380 M		10.14 €	C700 0380 FM	13.60 €
4.0	4x6x7x51	C700 0400 M		10.14 €	C700 0400 FM	13.60 €
4.5	4.5x6x7x51	C700 0450 M		10.14 €	C700 0450 FM	13.60 €
4.8	4.8x6x8x52	C700 0480 M		10.14 €	C700 0480 FM	13.60 €
5.0	5x6x8x52	C700 0500 M		10.14 €	C700 0500 FM	13.60 €
5.5	5.5x6x8x52	C700 0550 M		10.14 €	C700 0550 FM	13.60 €
5.75	5.75x6x8x52	C700 0575 M		10.14 €	C700 0575 FM	13.60 €
6.0	6x6x8x52	C700 0600 M		10.14 €	C700 0600 FM	13.60 €
6.5	6.5x10x10x60	C700 0650 M		14.47 €	C700 0650 FM	20.27 €
6.75	6.75x10x10x60	C700 0675 M		14.47 €	C700 0675 FM	20.27 €
7.0	7x10x10x60	C700 0700 M		14.47 €	C700 0700 FM	20.27 €
7.5	7.5x10x10x60	C700 0750 M		14.47 €	C700 0750 FM	20.27 €
7.75	7.75x10x11x61	C700 0775 M		14.47 €	C700 0775 FM	20.27 €
8.0	8x10x11x61	C700 0800 M		14.47 €	C700 0800 FM	20.27 €
8.5	8.5x10x11x61	C700 0850 M		14.47 €	C700 0850 FM	20.88 €
8.7	8.7x10x11x61	C700 0870 M		14.47 €	C700 0870 FM	20.88 €
9.0	9x10x11x61	C700 0900 M		14.47 €	C700 0900 FM	20.88 €
9.5	9.5x10x11x61	C700 0950 M		14.47 €	C700 0950 FM	20.88 €
9.7	9.7x10x13x63	C700 0970 M		14.47 €	C700 0970 FM	20.88 €
10.0	10x10x13x63	C700 1000 M		14.47 €	C700 1000 FM	20.88 €
10.5	10.5x12x13x70	C700 1050 M		19.29 €	C700 1050 FM	26.18 €
10.7	10.7x12x13x70	C700 1070 M		19.29 €	C700 1070 FM	26.18 €
11.0	11x12x13x70	C700 1100 M		19.29 €	C700 1100 FM	26.18 €
11.5	11.5x12x13x70	C700 1150 M		19.29 €	C700 1150 FM	26.18 €
11.7	11.7x12x16x73	C700 1170 M		19.29 €	C700 1170 FM	26.18 €
12.0	12x12x16x73	C700 1200 M		19.29 €	C700 1200 FM	26.18 €

voir suite ...

Tolérances selon DIN 7160 & 7161

Plage de tolérance en µm						
	Diamètre nominal en mm					
	de 1 à 3	plus de 3 à 6	plus de 6 à 10	plus de 10 à 18	plus de 18 à 30	plus de 30 à 50
e8	- 14 - 28	- 20 - 38	- 25 - 47	- 32 - 59	- 40 - 73	- 50 - 89
h6	0 - 6	0 - 8	0 - 9	0 - 11	0 - 13	0 - 16

FRAISES HSSCo8, 2 DENTS DIN 327 SÉRIE COURTE



réf. C700 *suite*

conditions de coupe recommandées p.128

Ø fraisage	Dimensions	Réf.		Prix unitaire TARIF H.T.	Réf.	
		non-revêtues			revêtues TiAlN	Prix unitaire TARIF H.T.
12.5	12.5x12x16x73	C700 1250 M		21.33 €	C700 1250 FM	28.22 €
12.7	12.7x12x16x73	C700 1270 M		21.33 €	C700 1270 FM	28.22 €
13.0	13x12x16x73	C700 1300 M		21.33 €	C700 1300 FM	28.28 €
13.5	13.5x12x16x73	C700 1350 M		21.33 €	C700 1350 FM	28.28 €
13.7	13.7x12x16x73	C700 1370 M		21.33 €	C700 1370 FM	28.28 €
14.0	14x12x16x73	C700 1400 M		21.33 €	C700 1400 FM	28.54 €
14.7	14.7x12x16x73	C700 1470 M		24.80 €	C700 1470 FM	32.12 €
15.0	15x12x16x73	C700 1500 M		24.80 €	C700 1500 FM	32.25 €
15.7	15.7x16x19x79	C700 1570 M		26.06 €	C700 1570 FM	34.33 €
16.0	16x16x19x79	C700 1600 M		26.06 €	C700 1600 FM	34.41 €
16.7	16.7x16x19x79	C700 1670 M		32.15 €	C700 1670 FM	40.59 €
17.0	17x16x19x79	C700 1700 M		32.15 €	C700 1700 FM	41.53 €
17.7	17.7x16x19x79	C700 1770 M		32.15 €	C700 1770 FM	41.53 €
18.0	18x16x19x79	C700 1800 M		32.15 €	C700 1800 FM	42.28 €
19.0	19x16x19x79	C700 1900 M		38.43 €	C700 1900 FM	50.69 €
19.7	19.7x20x22x88	C700 1970 M		38.43 €	C700 1970 FM	51.97 €
20.0	20x20x22x88	C700 2000 M		38.43 €	C700 2000 FM	53.86 €
21.0	21x20x22x88	C700 2100 M		42.82 €	C700 2100 FM	58.98 €
22.0	22x20x22x88	C700 2200 M		42.82 €	C700 2200 FM	59.17 €
24.0	24x25x26x102	C700 2400 M		61.62 €	C700 2400 FM	80.04 €
25.0	25x25x26x102	C700 2500 M		61.62 €	C700 2500 FM	80.58 €
26.0	26x25x26x102	C700 2600 M		81.96 €	C700 2600 FM	101.32 €
27.0	27x25x26x102	C700 2700 M		96.99 €	C700 2700 FM	116.53 €
28.0	28x25x26x102	C700 2800 M		96.99 €	C700 2800 FM	116.66 €
29.0	29x25x26x102	C700 2900 M		103.84 €	C700 2900 FM	123.60 €
30.0	30x25x26x102	C700 3000 M		103.84 €	C700 3000 FM	123.74 €
32.0	32x32x32x112	C700 3200 M		117.10 €	C700 3200 FM	147.30 €
34.0	34x32x32x112	C700 3400 M		143.46 €	C700 3400 FM	178.13 €
35.0	35x32x32x112	C700 3500 M		147.84 €	C700 3500 FM	184.26 €
36.0	36x32x32x112	C700 3600 M		152.39 €	C700 3600 FM	190.65 €
38.0	38x32x38x118	C700 3800 M		177.53 €	C700 3800 FM	219.73 €
40.0	40x40x38x130	C700 40001 M		177.53 €	C700 40001 FM	223.84 €

Tolérances selon DIN 7160 & 7161

	Plage de tolérance en µm					
	Diamètre nominal en mm					
	de 1 à 3	plus de 3 à 6	plus de 6 à 10	plus de 10 à 18	plus de 18 à 30	plus de 30 à 50
e8	- 14 - 28	- 20 - 38	- 25 - 47	- 32 - 59	- 40 - 73	- 50 - 89
h6	0 - 6	0 - 8	0 - 9	0 - 11	0 - 13	0 - 16

FRAISES HSSCo8, 2 DENTS DIN 844 SÉRIE NORMALE NON REVÊTUES ET REVÊTUES TiAIN



réf. C701

conditions de coupe recommandées p.128

Ø fraisage	Dimensions	Réf.		Prix unitaire TARIF H.T.	Réf.	
		non-revêtues			revêtues TiAIN	Prix unitaire TARIF H.T.
1.5	1.5x6x7x51	C701 0150 M		13.55 €	C701 0150 FM	17.03 €
2.0	2x6x7x51	C701 0200 M		12.57 €	C701 0200 FM	16.02 €
2.5	2.5x6x8x52	C701 0250 M		12.57 €	C701 0250 FM	16.02 €
3.0	3x6x8x52	C701 0300 M		12.57 €	C701 0300 FM	16.02 €
3.5	3.5x6x10x54	C701 0350 M		12.57 €	C701 0350 FM	16.02 €
4.0	4x6x11x55	C701 0400 M		12.57 €	C701 0400 FM	16.02 €
4.5	4.5x6x11x55	C701 0450 M		12.57 €	C701 0450 FM	16.02 €
5.0	5x6x13x57	C701 0500 M		12.57 €	C701 0500 FM	16.02 €
5.5	5.5x6x13x57	C701 0550 M		12.57 €	C701 0550 FM	16.02 €
6.0	6x6x13x57	C701 0600 M		12.57 €	C701 0600 FM	16.02 €
6.5	6.5x10x16x66	C701 0650 M		17.11 €	C701 0650 FM	22.96 €
7.0	7x10x16x66	C701 0700 M		17.11 €	C701 0700 FM	22.96 €
7.5	7.5x10x16x66	C701 0750 M		17.11 €	C701 0750 FM	22.96 €
8.0	8x10x19x69	C701 0800 M		17.11 €	C701 0800 FM	22.96 €
8.5	8.5x10x19x69	C701 0850 M		17.11 €	C701 0850 FM	23.57 €
9.0	9x10x19x69	C701 0900 M		17.11 €	C701 0900 FM	23.57 €
9.5	9.5x10x19x69	C701 0950 M		17.11 €	C701 0950 FM	23.57 €
10.0	10x10x22x72	C701 1000 M		17.11 €	C701 1000 FM	23.57 €
11.0	11x12x22x79	C701 1100 M		22.78 €	C701 1100 FM	29.97 €
12.0	12x12x26x83	C701 1200 M		22.78 €	C701 1200 FM	29.97 €
13.0	13x12x26x83	C701 1300 M		25.08 €	C701 1300 FM	32.51 €
14.0	14x12x26x83	C701 1400 M		25.08 €	C701 1400 FM	33.05 €
15.0	15x12x26x83	C701 1500 M		30.60 €	C701 1500 FM	38.98 €
16.0	16x16x32x92	C701 1600 M		30.60 €	C701 1600 FM	39.32 €
18.0	18x16x32x92	C701 1800 M		37.89 €	C701 1800 FM	48.34 €
20.0	20x20x38x104	C701 2000 M		45.27 €	C701 2000 FM	61.26 €
22.0	22x20x38x104	C701 2200 M		50.37 €	C701 2200 FM	67.66 €
24.0	24x25x45x121	C701 2400 M		72.53 €	C701 2400 FM	91.09 €
25.0	25x25x45x121	C701 2500 M		72.53 €	C701 2500 FM	91.69 €
26.0	26x25x45x121	C701 2600 M		90.20 €	C701 2600 FM	109.66 €
27.0	27x25x45x121	C701 2700 M		114.37 €	C701 2700 FM	134.18 €
28.0	28x25x45x121	C701 2800 M		114.37 €	C701 2800 FM	134.23 €
30.0	30x25x45x121	C701 3000 M		122.50 €	C701 3000 FM	142.52 €
32.0	32x32x53x133	C701 3200 M		138.07 €	C701 3200 FM	168.51 €
40.0	40x40x63x155	C701 4000 M		230.44 €	C701 4000 FM	284.02 €

Tolérances selon DIN 7160 & 7161

	Plage de tolérance en µm					
	Diamètre nominal en mm					
	de 1 à 3	plus de 3 à 6	plus de 6 à 10	plus de 10 à 18	plus de 18 à 30	plus de 30 à 50
e8	- 14 - 28	- 20 - 38	- 25 - 47	- 32 - 59	- 40 - 73	- 50 - 89
h6	0 - 6	0 - 8	0 - 9	0 - 11	0 - 13	0 - 16

FRAISES HSSCo8, 2 DENTS DIN 844 SÉRIE LONGUE NON REVÊTUES ET REVÊTUES TiAIN



réf. C702

conditions de coupe recommandées p.128

Ø fraisage	Dimensions	Réf.		Prix unitaire TARIF H.T.	Réf.	
		non-revêtues			revêtues TiAIN	Prix unitaire TARIF H.T.
2.5	2.5x6x8x56	C702 0250 M		13.97 €	C702 0250 FM	17.45 €
3.0	3x6x8x56	C702 0300 M		13.97 €	C702 0300 FM	17.45 €
3.5	3.5x6x10x59	C702 0350 M		13.97 €	C702 0350 FM	17.45 €
4.0	4x6x11x63	C702 0400 M		13.97 €	C702 0400 FM	17.45 €
4.5	4.5x6x11x63	C702 0450 M		13.97 €	C702 0450 FM	17.45 €
5.0	5x6x13x68	C702 0500 M		13.97 €	C702 0500 FM	17.45 €
5.5	5.5x6x13x68	C702 0550 M		13.97 €	C702 0550 FM	17.45 €
6.0	6x6x13x68	C702 0600 M		13.97 €	C702 0600 FM	17.45 €
6.5	6.5x10x16x80	C702 0650 M		19.64 €	C702 0650 FM	25.51 €
7.0	7x10x16x80	C702 0700 M		19.64 €	C702 0700 FM	25.51 €
8.0	8x10x19x88	C702 0800 M		19.64 €	C702 0800 FM	25.93 €
8.5	8.5x10x19x88	C702 0850 M		19.64 €	C702 0850 FM	26.05 €
9.0	9x10x19x88	C702 0900 M		19.64 €	C702 0900 FM	26.05 €
10.0	10x10x22x95	C702 1000 M		19.64 €	C702 1000 FM	26.05 €
12.0	12x12x26x110	C702 1200 M		26.06 €	C702 1200 FM	33.94 €
14.0	14x12x26x110	C702 1400 M		29.89 €	C702 1400 FM	38.23 €
16.0	16x16x32x123	C702 1600 M		36.46 €	C702 1600 FM	46.32 €
18.0	18x16x32x123	C702 1800 M		45.07 €	C702 1800 FM	57.43 €
20.0	20x20x38x141	C702 2000 M		53.81 €	C702 2000 FM	73.10 €
22.0	22x20x38x141	C702 2200 M		60.01 €	C702 2200 FM	79.64 €
24.0	24x25x45x166	C702 2400 M		86.23 €	C702 2400 FM	116.53 €
25.0	25x25x45x166	C702 2500 M		86.23 €	C702 2500 FM	116.94 €
26.0	26x25x45x166	C702 2600 M		97.34 €	C702 2600 FM	128.25 €
28.0	28x25x45x166	C702 2800 M		123.59 €	C702 2800 FM	155.11 €
30.0	30x25x45x166	C702 3000 M		132.34 €	C702 3000 FM	164.06 €
32.0	32x32x53x186	C702 3200 M		149.18 €	C702 3200 FM	205.99 €
36.0	36x32x53x186	C702 3600 M		194.25 €	C702 3600 FM	263.43 €
40.0	40x40x63x217	C702 40001 M		248.96 €	C702 40001 FM	350.07 €

Tolérances selon DIN 7160 & 7161

	Plage de tolérance en µm					
	Diamètre nominal en mm					
	de 1 à 3	plus de 3 à 6	plus de 6 à 10	plus de 10 à 18	plus de 18 à 30	plus de 30 à 50
e8	- 14 - 28	- 20 - 38	- 25 - 47	- 32 - 59	- 40 - 73	- 50 - 89
h6	0 - 6	0 - 8	0 - 9	0 - 11	0 - 13	0 - 16

FRAISES HSSCo8, 2 DENTS DIN 844 SÉRIE NORMALE ALUMINIUM



réf. C703

conditions de coupe recommandées p. 130

Ø fraisage	Dimensions	Réf.	Prix unitaire TARIF H.T.
1.0	1x6x3x49	C703 0100 M	16.36 €
1.5	1.5x6x5x49	C703 0150 M	16.36 €
2.0	2x6x7x51	C703 0200 M	16.36 €
2.5	2.5x6x8x52	C703 0250 M	16.36 €
3.0	3x6x8x52	C703 0300 M	16.36 €
3.5	3.5x6x10x54	C703 0350 M	16.36 €
4.0	4x6x11x55	C703 0400 M	16.36 €
4.5	4.5x6x11x55	C703 0450 M	16.36 €
5.0	5x6x13x57	C703 0500 M	16.36 €
5.5	5.5x6x13x57	C703 0550 M	16.36 €
6.0	6x6x13x57	C703 0600 M	16.36 €
6.5	6.5x10x16x66	C703 0650 M	22.29 €
7.0	7x10x16x66	C703 0700 M	22.29 €
7.5	7.5x10x16x66	C703 0750 M	22.29 €
8.0	8x10x19x69	C703 0800 M	22.29 €
8.5	8.5x10x19x69	C703 0850 M	22.29 €
9.0	9x10x19x69	C703 0900 M	22.29 €
10.0	10x10x22x72	C703 1000 M	22.29 €
11.0	11x12x22x79	C703 1100 M	29.56 €
12.0	12x12x26x83	C703 1200 M	29.56 €
13.0	13x12x26x83	C703 1300 M	32.62 €
14.0	14x12x26x83	C703 1400 M	32.62 €
15.0	15x12x26x83	C703 1500 M	39.84 €
16.0	16x16x32x92	C703 1600 M	39.84 €
17.0	17x16x32x92	C703 1700 M	49.25 €
18.0	18x16x32x92	C703 1800 M	49.25 €
19.0	19x16x32x92	C703 1900 M	58.77 €
20.0	20x20x38x104	C703 2000 M	58.77 €
21.0	21x20x38x104	C703 2100 M	94.19 €
22.0	22x20x38x104	C703 2200 M	94.19 €
23.0	23x20x38x104	C703 2300 M	94.19 €
24.0	24x25x45x121	C703 2400 M	94.19 €
25.0	25x25x45x121	C703 2500 M	94.19 €
26.0	26x25x45x121	C703 2600 M	125.35 €
28.0	28x25x45x121	C703 2800 M	148.82 €
30.0	30x25x45x121	C703 3000 M	159.31 €
32.0	32x32x53x133	C703 3200 M	179.56 €

Tolérances selon DIN 7160 & 7161

	Plage de tolérance en µm					
	Diamètre nominal en mm					
	de 1 à 3	plus de 3 à 6	plus de 6 à 10	plus de 10 à 18	plus de 18 à 30	plus de 30 à 50
e8	- 14 - 28	- 20 - 38	- 25 - 47	- 32 - 59	- 40 - 73	- 50 - 89
h6	0 - 6	0 - 8	0 - 9	0 - 11	0 - 13	0 - 16

FRAISES HSSCo8, 2 DENTS DIN 844 SÉRIE LONGUE ALUMINIUM



réf. C704

conditions de coupe recommandées p. 130

Ø fraissage	Dimensions	Réf.	Prix unitaire TARIF H.T.
2.0	2x6x10x54	C704 0200 M	21.45 €
3.0	3x6x12x56	C704 0300 M	21.45 €
4.0	4x6x19x63	C704 0400 M	21.45 €
5.0	5x6x24x68	C704 0500 M	21.45 €
6.0	6x6x24x68	C704 0600 M	21.45 €
7.0	7x10x30x80	C704 0700 M	30.04 €
8.0	8x10x38x88	C704 0800 M	30.04 €
9.0	9x10x38x88	C704 0900 M	30.04 €
10.0	10x10x45x95	C704 1000 M	30.04 €
11.0	11x12x45x102	C704 1100 M	39.90 €
12.0	12x12x53x110	C704 1200 M	39.90 €
13.0	13x12x53x110	C704 1300 M	45.63 €
14.0	14x12x53x110	C704 1400 M	45.63 €
15.0	15x12x53x110	C704 1500 M	52.48 €
16.0	16x16x63x123	C704 1600 M	55.69 €
18.0	18x16x63x123	C704 1800 M	68.95 €
20.0	20x20x75x141	C704 2000 M	82.31 €

Tolérances selon DIN 7160 & 7161

	Plage de tolérance en µm					
	Diamètre nominal en mm					
	de 1 à 3	plus de 3 à 6	plus de 6 à 10	plus de 10 à 18	plus de 18 à 30	plus de 30 à 50
e8	- 14 - 28	- 20 - 38	- 25 - 47	- 32 - 59	- 40 - 73	- 50 - 89
h6	0 - 6	0 - 8	0 - 9	0 - 11	0 - 13	0 - 16

FRAISES HSSCo8, 3 DENTS STANDARD CORAI EXTRA-COURTES NON REVÊTUES ET REVÊTUES TiAIN



réf. C710

conditions de coupe recommandées p.129, 130

Ø fraisage	Dimensions	Réf.		Prix unitaire TARIF H.T.	Réf.	
		non-revêtues			revêtues TiAIN	Prix unitaire TARIF H.T.
1.0	1x6x2x34	C710 0100 M		9.51 €	C710 0100 FM	12.92 €
1.3	1.3x6x3x34	C710 0130 M		9.51 €	C710 0130 FM	12.92 €
1.5	1.5x6x3x34	C710 0150 M		9.51 €	C710 0150 FM	12.92 €
1.8	1.8x6x3x34	C710 0180 M		9.51 €	C710 0180 FM	12.92 €
2.0	2x6x4x35	C710 0200 M		9.51 €	C710 0200 FM	12.92 €
2.3	2.3x6x4x35	C710 0230 M		9.51 €	C710 0230 FM	12.92 €
2.5	2.5x6x5x36	C710 0250 M		9.51 €	C710 0250 FM	12.92 €
2.8	2.8x6x5x36	C710 0280 M		9.51 €	C710 0280 FM	12.92 €
3.0	3x6x5x36	C710 0300 M		9.51 €	C710 0300 FM	12.92 €
3.3	3.3x6x6x37	C710 0330 M		9.51 €	C710 0330 FM	12.92 €
3.5	3.5x6x6x37	C710 0350 M		9.51 €	C710 0350 FM	12.92 €
3.8	3.8x6x7x38	C710 0380 M		9.51 €	C710 0380 FM	12.92 €
4.0	4x6x7x38	C710 0400 M		9.51 €	C710 0400 FM	12.92 €
4.3	4.3x6x7x38	C710 0430 M		9.51 €	C710 0430 FM	12.92 €
4.5	4.5x6x7x38	C710 0450 M		9.51 €	C710 0450 FM	12.92 €
4.8	4.8x6x8x39	C710 0480 M		9.51 €	C710 0480 FM	12.92 €
5.0	5x6x8x39	C710 0500 M		9.51 €	C710 0500 FM	12.92 €
5.3	5.3x6x8x39	C710 0530 M		9.51 €	C710 0530 FM	12.92 €
5.5	5.5x6x8x39	C710 0550 M		9.51 €	C710 0550 FM	12.92 €
5.75	5.75x6x8x39	C710 0575 M		9.51 €	C710 0575 FM	12.92 €
6.0	6x6x8x39	C710 0600 M		9.51 €	C710 0600 FM	12.92 €
6.5	6.5x8x10x42	C710 0650 M		11.19 €	C710 0650 FM	16.97 €
7.0	7x8x10x42	C710 0700 M		11.19 €	C710 0700 FM	16.97 €
7.5	7.5x8x10x42	C710 0750 M		11.19 €	C710 0750 FM	16.97 €
8.0	8x8x11x43	C710 0800 M		11.19 €	C710 0800 FM	16.97 €
8.5	8.5x10x11x48	C710 0850 M		14.40 €	C710 0850 FM	20.60 €
9.0	9x10x11x48	C710 0900 M		14.40 €	C710 0900 FM	20.60 €
9.5	9.5x10x11x48	C710 0950 M		14.40 €	C710 0950 FM	20.60 €
10.0	10x10x13x50	C710 1000 M		14.40 €	C710 1000 FM	20.60 €
12.0	12x12x16x58	C710 1200 M		19.14 €	C710 1200 FM	25.51 €
16.0	16x16x19x64	C710 1600 M		25.70 €	C710 1600 FM	33.33 €
20.0	20x20x22x78	C710 2000 M		38.08 €	C710 2000 FM	52.04 €

Tolérances selon DIN 7160 & 7161

	Plage de tolérance en µm					
	Diamètre nominal en mm					
	de 1 à 3	plus de 3 à 6	plus de 6 à 10	plus de 10 à 18	plus de 18 à 30	plus de 30 à 50
e8	- 14 - 28	- 20 - 38	- 25 - 47	- 32 - 59	- 40 - 73	- 50 - 89
h6	0 - 6	0 - 8	0 - 9	0 - 11	0 - 13	0 - 16

FRAISES HSSCo8, 3 DENTS DIN 327 SÉRIE COURTE NON REVÊTUES ET REVÊTUES TiAIN

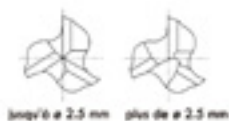

réf. C707

conditions de coupe recommandées p.129, 130

Ø fraisage	Dimensions	Réf.		Prix unitaire TARIF H.T.	Réf.	
		non-revêtues			revêtues TiAIN	Prix unitaire TARIF H.T.
1.5	1.5x6x3x47	C707 0150 M		10.14 €	C707 0150 FM	13.60 €
2.0	2x6x4x48	C707 0200 M		10.14 €	C707 0200 FM	13.60 €
2.5	2.5x6x5x49	C707 0250 M		10.14 €	C707 0250 FM	13.60 €
3.0	3x6x5x49	C707 0300 M		10.14 €	C707 0300 FM	13.60 €
3.5	3.5x6x6x50	C707 0350 M		10.14 €	C707 0350 FM	13.60 €
4.0	4x6x7x51	C707 0400 M		10.14 €	C707 0400 FM	13.60 €
4.5	4.5x6x7x51	C707 0450 M		10.14 €	C707 0450 FM	13.60 €
5.0	5x6x8x52	C707 0500 M		10.14 €	C707 0500 FM	13.60 €
5.5	5.5x6x8x52	C707 0550 M		10.14 €	C707 0550 FM	13.60 €
6.0	6x6x8x52	C707 0600 M		10.14 €	C707 0600 FM	13.60 €
6.5	6.5x10x10x60	C707 0650 M		14.47 €	C707 0650 FM	20.27 €
7.0	7x10x10x60	C707 0700 M		14.47 €	C707 0700 FM	20.27 €
7.5	7.5x10x10x60	C707 0750 M		14.47 €	C707 0750 FM	20.27 €
8.0	8x10x11x61	C707 0800 M		14.47 €	C707 0800 FM	20.27 €
8.5	8.5x10x11x61	C707 0850 M		14.47 €	C707 0850 FM	20.88 €
10.0	10x10x13x63	C707 1000 M		14.47 €	C707 1000 FM	20.88 €
12.0	12x12x16x73	C707 1200 M		19.29 €	C707 1200 FM	26.18 €
14.0	14x12x16x73	C707 1400 M		21.33 €	C707 1400 FM	28.54 €
15.0	15x12x16x73	C707 1500 M		24.80 €	C707 1500 FM	32.25 €
16.0	16x16x19x79	C707 1600 M		26.06 €	C707 1600 FM	34.41 €
18.0	18x16x19x79	C707 1800 M		32.15 €	C707 1800 FM	42.28 €
20.0	20x20x22x88	C707 2000 M		38.43 €	C707 2000 FM	53.86 €
22.0	22x20x22x88	C707 2200 M		42.82 €	C707 2200 FM	59.17 €
24.0	24x25x26x102	C707 2400 M		61.62 €	C707 2400 FM	80.04 €
25.0	25x25x26x102	C707 2500 M		61.62 €	C707 2500 FM	80.58 €
26.0	26x25x26x102	C707 2600 M		81.96 €	C707 2600 FM	101.32 €
28.0	28x25x26x102	C707 2800 M		96.99 €	C707 2800 FM	116.66 €
30.0	30x25x26x102	C707 3000 M		103.84 €	C707 3000 FM	123.74 €
32.0	32x32x32x112	C707 3200 M		117.10 €	C707 3200 FM	147.30 €

Tolérances selon DIN 7160 & 7161

	Plage de tolérance en µm					
	Diamètre nominal en mm					
	de 1 à 3	plus de 3 à 6	plus de 6 à 10	plus de 10 à 18	plus de 18 à 30	plus de 30 à 50
e8	- 14 - 28	- 20 - 38	- 25 - 47	- 32 - 59	- 40 - 73	- 50 - 89
h6	0 - 6	0 - 8	0 - 9	0 - 11	0 - 13	0 - 16

FRAISES HSSCo8, 3 DENTS DIN 844 SÉRIE NORMALE NON REVÊTUES ET REVÊTUES TiAIN



réf. C708

conditions de coupe recommandées p.129, 130

Ø fraisage	Dimensions	Réf.		Réf.	
		non-revêtues	Prix unitaire TARIF H.T.	revêtues TiAIN	Prix unitaire TARIF H.T.
1.0	1x6x3x47	C708 0100 M	13.55 €	C708 0100 FM	17.03 €
1.5	1.5x6x7x51	C708 0150 M	13.55 €	C708 0150 FM	17.03 €
2.0	2x6x7x51	C708 0200 M	12.57 €	C708 0200 FM	16.02 €
2.5	2.5x6x8x52	C708 0250 M	12.57 €	C708 0250 FM	16.02 €
3.0	3x6x8x52	C708 0300 M	12.57 €	C708 0300 FM	16.02 €
3.5	3.5x6x10x54	C708 0350 M	12.57 €	C708 0350 FM	16.02 €
4.0	4x6x11x55	C708 0400 M	12.57 €	C708 0400 FM	16.02 €
4.5	4.5x6x11x55	C708 0450 M	12.57 €	C708 0450 FM	16.02 €
5.0	5x6x13x57	C708 0500 M	12.57 €	C708 0500 FM	16.02 €
5.5	5.5x6x13x57	C708 0550 M	12.57 €	C708 0550 FM	16.02 €
6.0	6x6x13x57	C708 0600 M	12.57 €	C708 0600 FM	16.02 €
6.5	6.5x10x16x66	C708 0650 M	17.11 €	C708 0650 FM	22.96 €
7.0	7x10x16x66	C708 0700 M	17.11 €	C708 0700 FM	22.96 €
7.5	7.5x10x16x66	C708 0750 M	17.11 €	C708 0750 FM	22.96 €
8.0	8x10x19x69	C708 0800 M	17.11 €	C708 0800 FM	22.96 €
8.5	8.5x10x19x69	C708 0850 M	17.11 €	C708 0850 FM	23.57 €
9.0	9x10x19x69	C708 0900 M	17.11 €	C708 0900 FM	23.57 €
9.5	9.5x10x19x69	C708 0950 M	17.11 €	C708 0950 FM	23.57 €
10.0	10x10x22x72	C708 1000 M	17.11 €	C708 1000 FM	23.57 €
12.0	12x12x26x83	C708 1200 M	22.72 €	C708 1200 FM	29.89 €
14.0	14x12x26x83	C708 1400 M	25.08 €	C708 1400 FM	33.05 €
15.0	15x12x26x83	C708 1500 M	29.14 €	C708 1500 FM	37.50 €
16.0	16x16x32x92	C708 1600 M	30.60 €	C708 1600 FM	39.32 €
18.0	18x16x32x92	C708 1800 M	37.89 €	C708 1800 FM	48.34 €
20.0	20x20x38x104	C708 2000 M	45.27 €	C708 2000 FM	61.26 €
22.0	22x20x38x104	C708 2200 M	50.37 €	C708 2200 FM	67.66 €
24.0	24x25x45x121	C708 2400 M	72.53 €	C708 2400 FM	91.09 €
25.0	25x25x45x121	C708 2500 M	72.53 €	C708 2500 FM	91.69 €
26.0	26x25x45x121	C708 2600 M	90.20 €	C708 2600 FM	109.66 €
28.0	28x25x45x121	C708 2800 M	114.37 €	C708 2800 FM	134.23 €
30.0	30x25x45x121	C708 3000 M	122.50 €	C708 3000 FM	142.52 €
32.0	32x32x53x133	C708 3200 M	138.07 €	C708 3200 FM	168.51 €
40.0	40x40x63x155	C708 4000 M	230.44 €	C708 4000 FM	284.02 €

Tolérances selon DIN 7160 & 7161

	Plage de tolérance en µm					
	Diamètre nominal en mm					
	de 1 à 3	plus de 3 à 6	plus de 6 à 10	plus de 10 à 18	plus de 18 à 30	plus de 30 à 50
e8	- 14 - 28	- 20 - 38	- 25 - 47	- 32 - 59	- 40 - 73	- 50 - 89
h6	0 - 6	0 - 8	0 - 9	0 - 11	0 - 13	0 - 16

FRAISES HSSCo8, 3 DENTS DIN 844 SÉRIE LONGUE NON REVÊTUES ET REVÊTUES TiAIN



réf. C709

conditions de coupe recommandées p.129, 130

Ø fraisage	Dimensions	Réf.		Réf.	
		non-revêtues	Prix unitaire TARIF H.T.	revêtues TiAIN	Prix unitaire TARIF H.T.
2.0	2x6x10x54	C709 0200 M	16.36 €	C709 0200 FM	19.86 €
2.5	2.5x6x12x56	C709 0250 M	16.36 €	C709 0250 FM	19.86 €
3.0	3x6x12x56	C709 0300 M	16.36 €	C709 0300 FM	19.86 €
3.5	3.5x6x15x59	C709 0350 M	16.36 €	C709 0350 FM	19.86 €
4.0	4x6x19x63	C709 0400 M	16.36 €	C709 0400 FM	19.86 €
4.5	4.5x6x19x63	C709 0450 M	16.36 €	C709 0450 FM	19.86 €
5.0	5x6x24x68	C709 0500 M	16.36 €	C709 0500 FM	19.86 €
5.5	5.5x6x24x68	C709 0550 M	16.36 €	C709 0550 FM	19.86 €
6.0	6x6x24x68	C709 0600 M	16.36 €	C709 0600 FM	19.86 €
7.0	7x10x30x80	C709 0700 M	23.19 €	C709 0700 FM	29.15 €
7.5	7.5x10x30x80	C709 0750 M	23.19 €	C709 0750 FM	29.15 €
8.0	8x10x38x88	C709 0800 M	23.19 €	C709 0800 FM	29.55 €
9.0	9x10x38x88	C709 0900 M	23.19 €	C709 0900 FM	29.69 €
10.0	10x10x45x95	C709 1000 M	23.19 €	C709 1000 FM	29.69 €
11.0	11x12x45x102	C709 1100 M	30.60 €	C709 1100 FM	37.91 €
12.0	12x12x53x110	C709 1200 M	30.60 €	C709 1200 FM	38.52 €
14.0	14x12x53x110	C709 1400 M	35.08 €	C709 1400 FM	43.49 €
15.0	15x12x53x110	C709 1500 M	40.87 €	C709 1500 FM	49.55 €
16.0	16x16x63x123	C709 1600 M	42.82 €	C709 1600 FM	52.71 €
18.0	18x16x63x123	C709 1800 M	53.10 €	C709 1800 FM	65.51 €
19.0	19x16x63x123	C709 1900 M	63.30 €	C709 1900 FM	77.55 €
20.0	20x20x75x141	C709 2000 M	63.30 €	C709 2000 FM	82.73 €
22.0	22x20x75x141	C709 2200 M	70.63 €	C709 2200 FM	90.41 €
24.0	24x25x90x166	C709 2400 M	101.52 €	C709 2400 FM	132.01 €
25.0	25x25x90x166	C709 2500 M	101.52 €	C709 2500 FM	132.42 €
26.0	26x25x90x166	C709 2600 M	108.16 €	C709 2600 FM	139.16 €
28.0	28x25x90x166	C709 2800 M	137.37 €	C709 2800 FM	169.05 €
30.0	30x25x90x166	C709 3000 M	147.00 €	C709 3000 FM	178.94 €
32.0	32x32x106x186	C709 3200 M	165.81 €	C709 3200 FM	222.84 €
35.0	35x32x106x186	C709 3500 M	203.10 €	C709 3500 FM	269.15 €
36.0	36x32x106x186	C709 3600 M	215.83 €	C709 3600 FM	285.30 €
40.0	40x40x125x217	C709 4000 M	276.61 €	C709 4000 FM	378.00 €

Tolérances selon DIN 7160 & 7161

	Plage de tolérance en µm					
	Diamètre nominal en mm					
	de 1 à 3	plus de 3 à 6	plus de 6 à 10	plus de 10 à 18	plus de 18 à 30	plus de 30 à 50
e8	- 14 - 28	- 20 - 38	- 25 - 47	- 32 - 59	- 40 - 73	- 50 - 89
h6	0 - 6	0 - 8	0 - 9	0 - 11	0 - 13	0 - 16

FRAISES HSSCo8, 4 ET 6 DENTS DIN 844 SÉRIE NORMALE NON REVÊTUES ET REVÊTUES TiAlN



réf. C716

conditions de coupe recommandées p.128

Ø fraissage	Dimensions	Réf.		Prix unitaire TARIF H.T.	Réf.	
		non-revêtues			revêtues TiAlN	Prix unitaire TARIF H.T.
4 dents				4 dents		
2.0	2x6x7x51	C716 0200 M		12.57 €	C716 0200 FM	16.02 €
3.0	3x6x8x52	C716 0300 M		12.57 €	C716 0300 FM	16.02 €
4.0	4x6x11x55	C716 0400 M		12.57 €	C716 0400 FM	16.02 €
5.0	5x6x13x57	C716 0500 M		12.57 €	C716 0500 FM	16.02 €
6.0	6x6x13x57	C716 0600 M		12.57 €	C716 0600 FM	16.02 €
7.0	7x10x16x66	C716 0700 M		17.11 €	C716 0700 FM	22.96 €
8.0	8x10x19x69	C716 0800 M		17.11 €	C716 0800 FM	22.96 €
9.0	9x10x19x69	C716 0900 M		17.11 €	C716 0900 FM	23.57 €
10.0	10x10x22x72	C716 1000 M		17.11 €	C716 1000 FM	23.57 €
11.0	11x12x22x79	C716 1100 M		23.82 €	C716 1100 FM	31.04 €
12.0	12x12x26x83	C716 1200 M		23.82 €	C716 1200 FM	31.04 €
13.0	13x12x26x83	C716 1300 M		26.34 €	C716 1300 FM	33.80 €
14.0	14x12x26x83	C716 1400 M		26.34 €	C716 1400 FM	34.33 €
15.0	15x12x26x83	C716 1500 M		30.60 €	C716 1500 FM	38.98 €
16.0	16x16x32x92	C716 1600 M		32.15 €	C716 1600 FM	40.87 €
17.0	17x16x32x92	C716 1700 M		39.76 €	C716 1700 FM	49.55 €
18.0	18x16x32x92	C716 1800 M		39.76 €	C716 1800 FM	50.28 €
19.0	19x16x32x92	C716 1900 M		47.44 €	C716 1900 FM	61.06 €
20.0	20x20x38x104	C716 2000 M		47.44 €	C716 2000 FM	63.49 €
22.0	22x20x38x104	C716 2200 M		52.95 €	C716 2200 FM	70.28 €
25.0	25x25x45x121	C716 2500 M		76.17 €	C716 2500 FM	95.32 €
6 dents				6 dents		
22.0	22x20x38x104	C716 22001 M		52.95 €	C716 22001 FM	70.28 €
25.0	25x25x45x121	C716 25001 M		76.17 €	C716 25001 FM	95.32 €
26.0	26x25x45x121	C716 2600 M		98.95 €	C716 2600 FM	118.48 €
28.0	28x25x45x121	C716 2800 M		120.18 €	C716 2800 FM	140.09 €
30.0	30x25x45x121	C716 3000 M		128.63 €	C716 3000 FM	148.71 €
32.0	32x32x53x133	C716 3200 M		145.12 €	C716 3200 FM	175.64 €
34.0	34x32x53x133	C716 3400 M		177.68 €	C716 3400 FM	212.80 €
35.0	35x32x53x133	C716 3500 M		183.20 €	C716 3500 FM	220.07 €
36.0	36x32x53x133	C716 3600 M		188.79 €	C716 3600 FM	227.48 €
38.0	38x32x63x143	C716 3800 M		220.03 €	C716 3800 FM	262.76 €
40.0	40x40x63x155	C716 4000 M		220.03 €	C716 4000 FM	273.46 €
tolérance fraises (mm)		tolérance Ø queue				
0~+0.04		h6				

FRAISES HSSCo8, 4 ET 6 DENTS DIN 844 SÉRIE LONGUE NON REVÊTUES ET REVÊTUES TiAIN



réf. C717

conditions de coupe recommandées p.128

Ø fraisage	Dimensions	Réf.		Prix unitaire TARIF H.T.	Réf.		Prix unitaire TARIF H.T.
		non-revêtues			revêtues TiAIN		
4 dents				4 dents			
2.0	2x6x10x54	C717 0200 M		16.36 €	C717 0200 FM		19.86 €
2.5	2.5x6x12x56	C717 0250 M		16.36 €	C717 0250 FM		19.86 €
3.0	3x6x12x56	C717 0300 M		16.36 €	C717 0300 FM		19.86 €
3.5	3.5x6x15x59	C717 0350 M		16.36 €	C717 0350 FM		19.86 €
4.0	4x6x19x63	C717 0400 M		16.36 €	C717 0400 FM		19.86 €
4.5	4.5x6x19x63	C717 0450 M		16.36 €	C717 0450 FM		19.86 €
5.0	5 x 6 x 24 x 68	C717 0500 M		16.36 €	C717 0500 FM		19.86 €
5.5	5.5x6x24x68	C717 0550 M		16.36 €	C717 0550 FM		19.86 €
6.0	6 x 6 x 24 x 68	C717 0600 M		16.36 €	C717 0600 FM		19.86 €
7.0	7 x 10 x 30 x 80	C717 0700 M		23.19 €	C717 0700 FM		29.15 €
8.0	8 x 10 x 38 x 88	C717 0800 M		23.19 €	C717 0800 FM		29.55 €
9.0	9x10x38x88	C717 0900 M		23.19 €	C717 0900 FM		29.69 €
10.0	10x10x45x95	C717 1000 M		23.19 €	C717 1000 FM		29.69 €
11.0	11x12x45x102	C717 1100 M		32.21 €	C717 1100 FM		39.52 €
12.0	12x12x53x110	C717 1200 M		32.21 €	C717 1200 FM		40.12 €
13.0	13x12x53x110	C717 1300 M		36.82 €	C717 1300 FM		44.92 €
14.0	14x12x53x110	C717 1400 M		36.82 €	C717 1400 FM		45.24 €
15.0	15x12x53x110	C717 1500 M		42.82 €	C717 1500 FM		51.50 €
16.0	16 x 16 x 63 x 123	C717 1600 M		44.99 €	C717 1600 FM		54.93 €
17.0	17x16x63x123	C717 1700 M		55.69 €	C717 1700 FM		66.17 €
18.0	18x16x63x123	C717 1800 M		55.69 €	C717 1800 FM		68.13 €
19.0	19x16x63x123	C717 1900 M		66.46 €	C717 1900 FM		80.72 €
20.0	20x20x75x141	C717 2000 M		66.46 €	C717 2000 FM		85.91 €
6 dents				6 dents			
22.0	22x20x75x141	C717 2200 M		74.21 €	C717 2200 FM		94.05 €
24.0	24x25x90x166	C717 2400 M		106.55 €	C717 2400 FM		137.13 €
25.0	25x25x90x166	C717 2500 M		106.55 €	C717 2500 FM		137.47 €
26.0	26x25x90x166	C717 2600 M		113.62 €	C717 2600 FM		144.67 €
28.0	28x25x90x166	C717 2800 M		144.22 €	C717 2800 FM		175.91 €
30.0	30x25x90x166	C717 3000 M		154.34 €	C717 3000 FM		186.34 €
32.0	32x32x106x186	C717 3200 M		174.13 €	C717 3200 FM		231.25 €
36.0	36x32x106x186	C717 3600 M		226.59 €	C717 3600 FM		296.21 €
40.0	40x40x125x217	C717 4000 M		290.46 €	C717 4000 FM		392.01 €

	tolérance fraises (mm)	tolérance Ø queue
jusqu'au Ø6	0~+0.04	h6
au-dessus de Ø6	0~+0.05	

FRAISES HSSCo8, 2 DENTS HÉMISPHERIQUES DIN 327 SÉRIE COURTE NON REVÊTUES ET REVÊTUES TiAIN



réf. C719

conditions de coupe recommandées p.131

Ø fraissage	Dimensions	Réf.		Prix unitaire TARIF H.T.	Réf.	
		non-revêtues			revêtues TiAIN	Prix unitaire TARIF H.T.
2.0	2x6x4x48	C719 0200 M		16.07 €	C719 0200 FM	19.59 €
2.5	2.5x6x5x49	C719 0250 M		16.07 €	C719 0250 FM	19.59 €
3.0	3x6x5x49	C719 0300 M		16.07 €	C719 0300 FM	19.59 €
3.5	3.5x6x6x50	C719 0350 M		16.07 €	C719 0350 FM	19.59 €
4.0	4x6x7x51	C719 0400 M		16.07 €	C719 0400 FM	19.59 €
4.5	4.5x6x7x51	C719 0450 M		16.07 €	C719 0450 FM	19.59 €
5.0	5x6x8x52	C719 0500 M		16.07 €	C719 0500 FM	19.59 €
5.5	5.5x6x8x52	C719 0550 M		16.07 €	C719 0550 FM	19.59 €
6.0	6x6x8x52	C719 0600 M		16.07 €	C719 0600 FM	19.59 €
7.0	7x10x10x60	C719 0700 M		20.47 €	C719 0700 FM	26.40 €
8.0	8x10x11x61	C719 0800 M		20.47 €	C719 0800 FM	26.40 €
9.0	9x10x11x61	C719 0900 M		20.47 €	C719 0900 FM	26.93 €
10.0	10x10x13x63	C719 1000 M		20.47 €	C719 1000 FM	26.93 €
11.0	11x12x13x70	C719 1100 M		26.76 €	C719 1100 FM	33.73 €
12.0	12x12x16x73	C719 1200 M		26.76 €	C719 1200 FM	33.73 €
13.0	13x12x16x73	C719 1300 M		30.25 €	C719 1300 FM	37.30 €
14.0	14x12x16x73	C719 1400 M		30.25 €	C719 1400 FM	37.63 €
15.0	15x12x16x73	C719 1500 M		33.75 €	C719 1500 FM	41.27 €
16.0	16x16x19x79	C719 1600 M		34.94 €	C719 1600 FM	43.42 €
17.0	17x16x19x79	C719 1700 M		43.10 €	C719 1700 FM	52.64 €
18.0	18x16x19x79	C719 1800 M		43.10 €	C719 1800 FM	53.39 €
19.0	19x16x19x79	C719 1900 M		49.33 €	C719 1900 FM	61.73 €
20.0	20x20x22x88	C719 2000 M		49.33 €	C719 2000 FM	64.90 €
22.0	22x20x22x88	C719 2200 M		55.27 €	C719 2200 FM	71.76 €
24.0	24x25x26x102	C719 2400 M		73.98 €	C719 2400 FM	92.49 €
25.0	25x25x26x102	C719 2500 M		73.98 €	C719 2500 FM	93.10 €
26.0	26x25x26x102	C719 2600 M		99.35 €	C719 2600 FM	118.89 €
28.0	28x25x26x102	C719 2800 M		114.31 €	C719 2800 FM	134.18 €
30.0	30x25x26x102	C719 3000 M		121.08 €	C719 3000 FM	141.17 €
32.0	32x32x32x112	C719 3200 M		134.52 €	C719 3200 FM	164.94 €

tolérance fraises (mm)	tolérance Ø queue
0~-0.03	h6

FRAISES HSSCo8 2 DENTS HÉMISPHERIQUES DIN 844 SÉRIE LONGUE NON REVÊTUES ET REVÊTUES TiAIN



réf. C720

conditions de coupe recommandées p.131

Ø fraisage	Dimensions	Réf.		Réf.	
		non-revêtues	Prix unitaire TARIF H.T.	revêtues TiAIN	Prix unitaire TARIF H.T.
2.0	2x6x7x54	C720 0200 M	19.91 €	C720 0200 FM	23.50 €
3.0	3x6x8x56	C720 0300 M	19.91 €	C720 0300 FM	23.50 €
4.0	4x6x11x63	C720 0400 M	19.91 €	C720 0400 FM	23.50 €
5.0	5x6x13x68	C720 0500 M	19.91 €	C720 0500 FM	23.50 €
6.0	6x6x13x68	C720 0600 M	19.91 €	C720 0600 FM	23.50 €
7.0	7x10x16x80	C720 0700 M	25.56 €	C720 0700 FM	31.51 €
8.0	8x10x19x88	C720 0800 M	25.56 €	C720 0800 FM	31.98 €
9.0	9x10x19x88	C720 0900 M	25.56 €	C720 0900 FM	32.12 €
10.0	10x10x22x95	C720 1000 M	25.56 €	C720 1000 FM	32.12 €
11.0	11x12x22x102	C720 1100 M	33.54 €	C720 1100 FM	40.87 €
12.0	12x12x26x110	C720 1200 M	33.54 €	C720 1200 FM	41.47 €
13.0	13x12x26x110	C720 1300 M	38.70 €	C720 1300 FM	46.79 €
14.0	14x12x26x110	C720 1400 M	38.70 €	C720 1400 FM	47.13 €
15.0	15x12x26x110	C720 1500 M	43.68 €	C720 1500 FM	52.38 €
16.0	16x16x32x123	C720 1600 M	45.41 €	C720 1600 FM	55.34 €
17.0	17x16x32x123	C720 1700 M	55.97 €	C720 1700 FM	66.45 €
18.0	18x16x32x123	C720 1800 M	55.97 €	C720 1800 FM	68.39 €
19.0	19x16x32x123	C720 1900 M	64.77 €	C720 1900 FM	79.04 €
20.0	20x20x38x141	C720 2000 M	64.77 €	C720 2000 FM	84.22 €
22.0	22x20x38x141	C720 2200 M	72.47 €	C720 2200 FM	92.24 €
24.0	24x25x45x166	C720 2400 M	98.66 €	C720 2400 FM	129.12 €
25.0	25x25x45x166	C720 2500 M	98.66 €	C720 2500 FM	129.53 €
26.0	26x25x45x166	C720 2600 M	114.71 €	C720 2600 FM	145.81 €
28.0	28x25x45x166	C720 2800 M	140.93 €	C720 2800 FM	172.61 €
30.0	30x25x45x166	C720 3000 M	149.66 €	C720 3000 FM	181.57 €

tolérance fraises (mm)	tolérance Ø queue
0--0.03	h6

FRAISES HSSCo8, MULTI-DENTS ÉBAUCHE PAS FINS DIN 844 SERIE NORMALE NON REVÊTUES ET REVÊTUES TiAIN



réf. C734

conditions de coupe recommandées p.132

Ø fraisage	Dimensions	Réf.		Réf.	Prix unitaire TARIF H.T.
		non-revêtues			
3 dents				2 dents	
6.0	6x6x13x57	C734 0600 M	29.89 €	C734 0600 FM	33.59 €
7.0	7x10x16x66	C734 0700 M	31.79 €	C734 0700 FM	37.83 €
8.0	8x10x19x69	C734 0800 M	31.79 €	C734 0800 FM	37.83 €
9.0	9x10x19x69	C734 0900 M	31.79 €	C734 0900 FM	38.38 €
4 dents				4 dents	
10.0	10x10x22x72	C734 1000 M	31.79 €	C734 1000 FM	38.38 €
11.0	11x12x22x79	C734 1100 M	35.30 €	C734 1100 FM	42.62 €
12.0	12x12x26x83	C734 1200 M	35.30 €	C734 1200 FM	42.62 €
13.0	13x12x26x83	C734 1300 M	44.94 €	C734 1300 FM	52.58 €
14.0	14x12x26x83	C734 1400 M	44.94 €	C734 1400 FM	53.18 €
15.0	15x12x26x83	C734 1500 M	48.34 €	C734 1500 FM	56.89 €
16.0	16x16x32x92	C734 1600 M	50.37 €	C734 1600 FM	59.31 €
18.0	18x16x32x92	C734 1800 M	52.88 €	C734 1800 FM	63.55 €
20.0	20x20x38x104	C734 2000 M	60.94 €	C734 2000 FM	77.15 €
5 dents				5 dents	
25.0	25x25x45x121	C734 2500 M	93.06 €	C734 2500 FM	112.49 €
6 dents				6 dents	
28.0	28x25x45x121	C734 2800 M	137.93 €	C734 2800 FM	158.07 €
30.0	30x25x45x121	C734 3000 M	137.93 €	C734 3000 FM	158.14 €
32.0	32x32x53x133	C734 3200 M	150.77 €	C734 3200 FM	181.36 €
35.0	35x32x53x133	C734 3500 M	218.21 €	C734 3500 FM	255.49 €
40.0	40x32x63x155	C734 4000 M	240.62 €	C734 4000 FM	294.33 €

Tolérances selon DIN 7160 & 7161

	Plage de tolérance en µm					
	Diamètre nominal en mm					
	de 1 à 3	plus de 3 à 6	plus de 6 à 10	plus de 10 à 18	plus de 18 à 30	plus de 30 à 50
js12	±50	±60	±75	±90	±105	±125
h6	0 - 6	0 - 8	0 - 9	0 - 11	0 - 13	0 - 16

FRAISES HSSCo8, MULTI-DENTS ÉBAUCHE PAS FINS DIN 844 SÉRIE LONGUE NON REVÊTUES ET REVÊTUES TiAIN

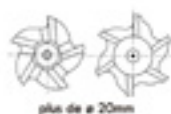

réf. C735

conditions de coupe recommandées p.132

Ø fraisage	Dimensions	Réf.		Réf.	
		non-revêtues	Prix unitaire TARIF H.T.	revêtues TiAIN	Prix unitaire TARIF H.T.
3 dents					
6.0	6x6x24x68	C735 0600 M	38.49 €	C735 0600 FM	42.28 €
7.0	7x10x30x80	C735 0700 M	41.66 €	C735 0700 FM	47.80 €
8.0	8x10x38x88	C735 0800 M	41.66 €	C735 0800 FM	48.21 €
9.0	9x10x38x88	C735 0900 M	41.66 €	C735 0900 FM	48.34 €
4 dents					
10.0	10x10x45x95	C735 1000 M	41.66 €	C735 1000 FM	48.34 €
11.0	11x12x45x102	C735 1100 M	48.09 €	C735 1100 FM	55.54 €
12.0	12x12x53x110	C735 1200 M	48.09 €	C735 1200 FM	56.21 €
13.0	13x12x53x110	C735 1300 M	67.35 €	C735 1300 FM	75.81 €
14.0	14x12x53x110	C735 1400 M	67.35 €	C735 1400 FM	76.14 €
15.0	15x12x53x110	C735 1500 M	70.63 €	C735 1500 FM	79.64 €
16.0	16x16x63x123	C735 1600 M	70.63 €	C735 1600 FM	80.86 €
17.0	17x16x63x123	C735 1700 M	80.22 €	C735 1700 FM	90.95 €
18.0	18x16x63x123	C735 1800 M	80.22 €	C735 1800 FM	92.97 €
19.0	19x16x63x123	C735 1900 M	88.25 €	C735 1900 FM	102.79 €
20.0	20x20x75x141	C735 2000 M	88.25 €	C735 2000 FM	107.91 €
5 dents					
22.0	22x20x75x141	C735 2200 M	121.93 €	C735 2200 FM	142.31 €
24.0	24x25x90x166	C735 2400 M	134.79 €	C735 2400 FM	165.68 €
25.0	25x25x90x166	C735 2500 M	134.79 €	C735 2500 FM	166.01 €
6 dents					
26.0	26x25x90x166	C735 2600 M	147.58 €	C735 2600 FM	179.07 €
28.0	28x25x90x166	C735 2800 M	176.42 €	C735 2800 FM	208.56 €
30.0	30x25x90x166	C735 3000 M	205.71 €	C735 3000 FM	238.32 €
32.0	32x32x106x186	C735 3200 M	218.21 €	C735 3200 FM	275.81 €
35.0	35x32x106x186	C735 3500 M	265.01 €	C735 3500 FM	331.82 €
36.0	36x32x106x186	C735 3600 M	265.01 €	C735 3600 FM	335.05 €
38.0	38x32x125x217	C735 3800 M	291.99 €	C735 3800 FM	384.47 €
40.0	40x40x125x217	C735 40001 M	314.35 €	C735 40001 FM	416.18 €

Tolérances selon DIN 7160 & 7161

	Plage de tolérance en µm					
	Diamètre nominal en mm					
	de 1 à 3	plus de 3 à 6	plus de 6 à 10	plus de 10 à 18	plus de 18 à 30	plus de 30 à 50
js12	±50	±60	±75	±90	±105	±125
h6	0 - 6	0 - 8	0 - 9	0 - 11	0 - 13	0 - 16

HSSCo8, 2 DENTS – RAINURAGE

réf. C700, C701, C702

Matière Usinée	Aciers carbone Aciers alliés Aciers à outil		Aciers carbone Aciers alliés Aciers à outil		Aciers carbone Aciers alliés Aciers à outil		Aciers carbone Aciers alliés Aciers à outil		Aluminium Aluminium allié	
DURETÉ	~ 500N/mm ²		~ HRc20		HRc20 ~ HRc30		HRc30 ~ HRc40			
RESISTANCE	~ 500N/mm ²		500 ~ 800N/mm ²		800 ~ 1000N/mm ²		1000 ~ 1300N/mm ²			
DIAMETRE	RPM	Avance	RPM	Avance	RPM	Avance	RPM	Avance	RPM	Avance
2.0	5 600	40	4 500	30	4 000	30	2 200	15	12 000	160
3.0	3 500	55	3 200	45	2 500	40	1 600	20	11 000	250
4.0	2 800	70	2 200	55	1 800	45	1 100	30	8 000	290
5.0	2 200	90	1 800	70	1 600	60	900	35	6 300	310
6.0	1 800	90	1 600	80	1 200	60	800	40	5 600	310
8.0	1 400	100	1 100	90	900	70	560	45	4 000	390
10.0	1 100	100	900	90	800	80	450	45	3 100	400
12.0	900	110	800	100	630	80	400	50	2 500	380
14.0	800	110	700	90	560	80	350	50	2 200	350
16.0	700	110	560	90	450	70	280	45	2 000	350
18.0	630	100	500	90	400	70	250	45	1 800	350
20.0	560	100	450	90	400	70	220	45	1 600	320
22.0	500	100	450	90	350	70	220	45	1 400	300
25.0	450	90	400	80	310	60	180	35	1 200	280
28.0	400	80	350	70	280	55	160	30	1 100	270
30.0	350	70	310	60	250	50	160	30	1 100	270
32.0	350	70	280	55	220	45	140	30	1 000	240
36.0	310	60	250	50	200	40	120	25	900	220
40.0	280	60	220	50	180	40	110	25	800	200

► Pour les types longs et extra-longs, l'avance peut être réduite d'environ 50%

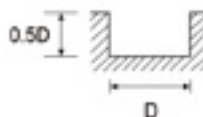

R.P.M. = tours/minute
Avance = mm/minute

HSSCo8, MULTI DENTS – USINAGE LATÉRAL

réf. C716, C717

Matière Usinée	Aciers carbone Aciers alliés Aciers à outil		Aciers carbone Aciers alliés Aciers à outil		Aciers carbone Aciers alliés Aciers à outil		Aciers carbone Aciers alliés Aciers à outil		Aluminium Aluminium allié	
DURETÉ	~ 500N/mm ²		~ HRc20		HRc20 ~ HRc30		HRc30 ~ HRc40			
RESISTANCE	~ 500N/mm ²		500 ~ 800N/mm ²		800 ~ 1000N/mm ²		1000 ~ 1300N/mm ²			
DIAMETRE	RPM	Avance	RPM	Avance	RPM	Avance	RPM	Avance	RPM	Avance
2.0	5 600	80	4 500	55	4 000	45	2 200	20	12 000	240
3.0	3 500	110	3 200	80	2 500	60	1 600	30	11 000	380
4.0	2 800	140	2 200	100	1 800	65	1 100	45	8 000	440
5.0	2 200	180	1 800	125	1 600	90	900	50	6 300	470
6.0	1 800	180	1 600	145	1 200	90	800	60	5 600	470
8.0	1 400	200	1 100	160	900	105	560	65	4 000	580
10.0	1 100	200	900	160	800	120	450	65	3 100	600
12.0	900	220	800	180	630	120	400	75	2 500	570
14.0	800	220	700	160	560	120	350	75	2 200	530
16.0	700	220	560	160	450	105	280	65	2 000	530
18.0	630	200	500	160	400	105	250	65	1 800	530
20.0	560	200	450	160	400	105	220	65	1 600	480
22.0	500	200	450	160	350	105	220	65	1 400	450
25.0	450	180	400	145	310	90	180	50	1 200	420
28.0	400	160	350	125	280	80	160	45	1 100	400
30.0	350	140	310	110	250	75	160	45	1 100	400
32.0	350	140	280	100	220	65	140	45	1 000	360
36.0	310	120	250	90	200	60	120	35	900	330
40.0	280	120	220	90	180	60	110	35	800	300

► Pour les types longs et extra-longs, l'avance peut être réduite d'environ 50%



R.P.M. = tours/minute
Avance = mm/minute

HSSCo8, 3 DENTS – RAINURAGE

réf. C707, C708, C709, C710

Matière Usinée	Aciers carbone Aciers alliés Aciers à outil		Aciers carbone Aciers alliés Aciers à outil		Aciers carbone Aciers alliés Aciers à outil		Aciers carbone Aciers alliés Aciers à outil		Aluminium Aluminium allié	
DURETÉ			~ HRC20		HRC20 ~ HRC30		HRC30 ~ HRC40			
RESISTANCE	~ 500N/mm ²		500 ~ 800N/mm ²		800 ~ 1000N/mm ²		1000 ~ 1300N/mm ²			
DIAMETRE	RPM	Avance	RPM	Avance	RPM	Avance	RPM	Avance	RPM	Avance
2.0	5600	35	4500	25	4000	20	2200	10	12000	110
3.0	3500	50	3200	35	2500	25	1600	15	11000	170
4.0	2800	60	2200	45	1800	30	1100	20	8000	200
5.0	2200	80	1800	55	1600	40	900	20	6300	210
6.0	1800	80	1600	65	1200	40	800	25	5600	210
8.0	1400	90	1100	70	900	50	560	30	4000	260
10.0	1100	90	900	70	800	55	450	30	3100	270
12.0	900	100	800	80	630	55	400	35	2500	260
14.0	800	100	700	70	560	55	350	35	2200	240
16.0	700	100	560	70	450	50	280	30	2000	240
18.0	630	90	500	70	400	50	250	30	1800	240
20.0	560	90	450	70	400	50	220	30	1600	220
22.0	500	90	450	70	350	50	220	30	1400	200
25.0	450	80	400	65	310	40	180	20	1200	190
28.0	400	70	350	55	280	35	160	20	1100	180
30.0	350	60	310	50	250	30	160	20	1100	180
32.0	350	60	280	45	220	30	140	20	1000	160
35.0	320	55	260	40	210	25	130	15	950	150
36.0	310	55	250	40	200	25	120	15	900	150
40.0	280	55	220	40	180	25	110	15	800	130

► Pour les types longs et extra-longs,
l'avance peut être réduite d'environ 50%

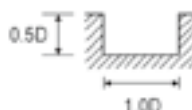

R.P.M. = tours/minute
Avance = mm/minute

HSSCo8, 3 DENTS REVÊTUES TiAlN – RAINURAGE

réf. C707FM, C708FM, C709FM, C710FM

Matière Usinée	Aciers carbone Aciers alliés Aciers à outil		Aciers carbone Aciers alliés Aciers à outil		Aciers carbone Aciers alliés Aciers à outil		Aciers carbone Aciers alliés Aciers à outil		Aluminium Aluminium allié	
DURETÉ			~ HRC20		HRC20 ~ HRC30		HRC30 ~ HRC40			
RESISTANCE	~ 500N/mm ²		500 ~ 800N/mm ²		800 ~ 1000N/mm ²		1000 ~ 1300N/mm ²			
DIAMETRE	RPM	Avance	RPM	Avance	RPM	Avance	RPM	Avance	RPM	Avance
2	7900	50	6300	35	5600	30	3100	15	16800	150
3	4900	70	4500	50	3500	35	2200	20	15400	240
4	3900	85	3100	60	2500	40	1500	30	11200	280
5	3100	110	2500	75	2200	55	1300	30	8800	290
6	2500	110	2200	90	1700	55	1100	35	7800	290
8	2000	125	1500	100	1300	70	780	40	5600	360
10	1500	125	1300	110	1100	75	630	40	4300	380
12	1300	140	1100	110	880	75	560	50	3500	360
14	1100	140	980	100	780	75	490	50	3100	340
16	980	140	780	100	630	70	390	40	2800	340
18	880	125	700	100	560	70	350	40	2500	340
20	780	125	630	100	560	70	310	40	2200	310
22	700	125	630	100	490	70	310	40	1950	280
25	630	110	560	90	430	55	250	30	1700	270
28	560	100	490	75	390	50	220	30	1500	250
30	490	85	430	70	350	40	220	30	1500	250
32	490	85	390	65	310	40	200	30	1400	225
35	450	80	360	60	290	35	180	25	1300	215
36	430	75	350	55	280	35	170	20	1250	210
40	390	75	310	55	250	35	150	20	1100	180

► Pour les types longs et extra-longs,
l'avance peut être réduite d'environ 50%

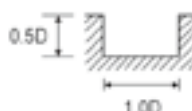

R.P.M. = tours/minute
Avance = mm/minute

HSSCo8, 3 DENTS – USINAGE LATÉRAL

réf. C707, C708, C709, C710

Matière Usinée	Aciers carbone Aciers alliés Aciers à outil		Aciers carbone Aciers alliés Aciers à outil		Aciers carbone Aciers alliés Aciers à outil		Aciers carbone Aciers alliés Aciers à outil		Aluminium Aluminium allié	
DURETÉ			~ HRc20		HRc20 ~ HRc30		HRc30 ~ HRc40			
RESISTANCE	~ 500N/mm ²		500 ~ 800N/mm ²		800 ~ 1000N/mm ²		1000 ~ 1300N/mm ²			
DIAMETRE	RPM	Avance	RPM	Avance	RPM	Avance	RPM	Avance	RPM	Avance
2.0	5600	60	4500	40	4000	35	2200	15	12000	180
3.0	3500	80	3200	60	2500	45	1600	20	11000	280
4.0	2800	105	2200	75	1800	50	1100	30	8000	330
5.0	2200	135	1800	95	1600	65	900	35	6300	350
6.0	1800	135	1600	110	1200	65	800	45	5600	350
8.0	1400	150	1100	120	900	80	560	50	4000	440
10.0	1100	150	900	120	800	90	450	50	3100	450
12.0	900	165	800	135	630	90	400	55	2500	430
14.0	800	165	700	120	560	90	350	55	2200	400
16.0	700	165	560	120	450	80	280	50	2000	400
18.0	630	150	500	120	400	80	250	50	1800	400
20.0	560	150	450	120	400	80	220	50	1600	360
22.0	500	150	450	120	350	80	220	50	1400	340
25.0	450	135	400	110	310	65	180	35	1200	320
28.0	400	120	350	95	280	60	160	30	1100	300
30.0	350	105	310	80	250	55	160	30	1100	300
32.0	350	105	280	75	220	50	140	30	1000	270
35.0	320	95	260	65	210	45	130	25	950	260
36.0	310	90	250	65	200	45	120	25	900	250
40.0	280	90	220	65	180	45	110	25	800	220

► Pour les types longs et extra-longs,
l'avance peut être réduite d'environ 50%



R.P.M. = tours/minute
Avance = mm/minute

HSSCo8, 2 DENTS - RAINURAGE

réf. C703, C704

Matière Usinée	Aluminium	
DIAMETRE	RPM	Avance
3.0	8000	560
6.0	7000	700
8.0	6000	850
10.0	5000	1200
12.0	5000	1200
14.0	3500	1240
16.0	3500	1240
18.0	2300	1300
20.0	2300	1300

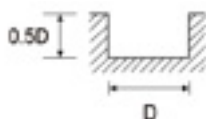

HSSCo8, 2 DENTS - USINAGE LATÉRAL

réf. C703, C704

Matière Usinée	Aluminium	
DIAMETRE	RPM	Avance
3.0	8000	730
6.0	7000	900
8.0	6000	1100
10.0	5000	1500
12.0	5000	1500
14.0	3500	1600
16.0	3500	1600
18.0	2300	1700
20.0	2300	1700

A : Ø3 ~ Ø10=0.25xD
Ø12 ~ Ø20=0.5xD



R.P.M. = tours/minute
Avance = mm/minute

HSSCo8, HÉMIPHERIQUE 2 DENTS

réf. C719, C720

Matière Usinée	Aciers carbone Aciers alliés Aciers à outil		Aciers carbone Aciers alliés Aciers à outil		Aciers carbone Aciers alliés Aciers à outil		Aciers carbone Aciers alliés Aciers à outil		Aluminium Aluminium allié	
DURETÉ			~ HRc20		HRc20 ~ HRc30		HRc30 ~ HRc40			
RESISTANCE	~ 500N/mm ²		500 ~ 800N/mm ²		800 ~ 1000N/mm ²		1000 ~ 1300N/mm ²			
DIAMETRE	RPM	Avance	RPM	Avance	RPM	Avance	RPM	Avance	RPM	Avance
R1.5 × 3.0	4 500	95	3 400	70	2 000	30	1 400	20	11 000	230
R2.0 × 4.0	3 200	115	2 400	80	1 400	35	1 000	25	8 000	260
R3.0 × 6.0	2 200	135	1 700	90	1 000	45	700	25	5 600	280
R4.0 × 8.0	1 600	160	1 200	105	700	50	500	30	4 000	350
R5.0 × 10.0	1 300	180	1 000	120	560	60	400	35	3 200	360
R6.0 × 12.0	1 000	170	800	105	450	55	320	35	2 500	340
R8.0 × 16.0	800	150	600	100	350	55	250	35	2 000	300
R10.0 × 20.0	600	140	500	85	300	50	200	35	1 600	280
R12.5 × 25.0	500	130	400	70	220	40	160	30	1 300	250

► Pour les types longs et extra-longs, l'avance peut être réduite d'environ 50%

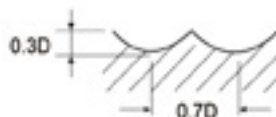

R.P.M. = tours/minute
Avance = mm/minute

HSSCo8, HÉMIPHERIQUE 2 DENTS TiAIN

réf. C719FM, C720FM

Matière Usinée	Aciers carbone Aciers alliés Aciers à outil		Aciers carbone Aciers alliés Aciers à outil		Aciers carbone Aciers alliés Aciers à outil		Aciers carbone Aciers alliés Aciers à outil		Aluminium Aluminium allié	
DURETÉ			~ HRc20		HRc20 ~ HRc30		HRc30 ~ HRc40			
RESISTANCE	~ 500N/mm ²		500 ~ 800N/mm ²		800 ~ 1000N/mm ²		1000 ~ 1300N/mm ²			
DIAMETRE	RPM	Avance	RPM	Avance	RPM	Avance	RPM	Avance	RPM	Avance
R1.5 × 3.0	6300	135	4750	100	2800	40	1950	30	15400	320
R2.0 × 4.0	4500	160	3350	110	1950	50	1400	35	11200	365
R3.0 × 6.0	3100	190	2400	125	1400	65	1000	35	7850	390
R4.0 × 8.0	2250	225	1700	145	1000	70	700	40	5600	490
R5.0 × 10.0	1800	250	1400	170	800	85	550	50	4500	505
R6.0 × 12.0	1400	240	1100	145	650	75	450	50	3500	475
R8.0 × 16.0	1100	210	850	140	500	75	350	50	2800	420
R10.0 × 20.0	850	195	700	120	400	70	300	50	2250	390
R12.5 × 25.0	700	180	550	100	300	55	200	40	1800	350

► Pour les types longs et extra-longs, l'avance peut être réduite d'environ 50%

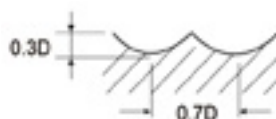

R.P.M. = tours/minute
Avance = mm/minute

HSSCo8, MULTI DENTS ÉBAUCHE – USINAGE LATÉRAL

réf. C734, C735

Matière Usinée	Aciers carbone Aciers alliés Aciers à outil		Aciers carbone Aciers alliés Aciers à outil		Aciers carbone Aciers alliés Aciers à outil		Aciers carbone Aciers alliés Aciers à outil		Aluminium Aluminium allié	
DURETÉ			~ HRc20		HRc20 ~ HRc30		HRc30 ~ HRc40			
RESISTANCE	~ 500N/mm ²		500 ~ 800N/mm ²		800 ~ 1000N/mm ²		1000 ~ 1300N/mm ²			
DIAMETRE	RPM	Avance	RPM	Avance	RPM	Avance	RPM	Avance	RPM	Avance
6.0	1 800	80	1 600	60	1 200	55	800	30	4 500	200
8.0	1 400	105	1 100	75	900	65	560	35	3 100	230
10.0	1 100	150	900	120	800	110	450	60	2 500	350
12.0	900	180	800	140	630	110	400	70	2 000	400
14.0	800	180	700	140	560	110	350	70	1 800	420
16.0	700	180	560	140	450	110	280	70	1 600	450
18.0	630	180	500	140	400	110	250	70	1 400	470
20.0	560	180	450	140	400	110	220	70	1 200	500
22.0	500	220	450	170	350	140	220	85	1 100	470
25.0	450	220	400	170	310	140	180	85	1 000	450
28.0	400	210	350	160	280	130	160	85	900	510
30.0	350	210	310	160	250	130	160	85	900	530
32.0	350	210	280	160	220	130	140	85	800	500
36.0	310	210	250	160	200	130	120	85	700	470
40.0	280	200	220	150	180	120	110	80	630	450
50.0	220	200	180	170	160	140	90	80	500	370

► Pour les types longs et extra-longs, l'avance peut être réduite d'environ 50%



R.P.M. = tours/minute
Avance = mm/minute

HSSCo8, MULTI DENTS REVÊTUES TiAIN ÉBAUCHE – USINAGE LATÉRAL

réf. C734FM, C735FM

Matière Usinée	Aciers carbone Aciers alliés Aciers à outil		Aciers carbone Aciers alliés Aciers à outil		Aciers carbone Aciers alliés Aciers à outil		Aciers carbone Aciers alliés Aciers à outil		Aluminium Aluminium allié	
DURETÉ			~ HRc20		HRc20 ~ HRc30		HRc30 ~ HRc40			
RESISTANCE	~ 500N/mm ²		500 ~ 800N/mm ²		800 ~ 1000N/mm ²		1000 ~ 1300N/mm ²			
DIAMETRE	RPM	Avance	RPM	Avance	RPM	Avance	RPM	Avance	RPM	Avance
6.0	2500	110	2250	85	1700	75	1100	40	6300	280
8.0	1950	145	1550	105	1250	90	800	50	4350	320
10.0	1550	210	1250	170	1100	155	650	85	3500	490
12.0	1250	250	1100	195	900	155	550	100	2800	560
14.0	1100	250	1000	195	800	155	500	100	2500	590
16.0	1000	250	800	195	650	155	400	100	2250	630
18.0	900	250	700	195	550	155	350	100	1950	660
20.0	800	250	650	195	550	155	300	100	1700	700
22.0	700	310	650	240	500	195	300	120	1550	660
25.0	650	310	550	240	450	195	250	120	1400	630
28.0	550	295	500	225	400	180	220	120	1250	715
30.0	500	295	450	225	350	180	220	120	1250	740
32.0	500	295	400	225	300	180	200	120	1100	700
36.0	450	295	350	225	300	180	170	120	1000	660
40.0	400	280	300	210	250	170	130	110	900	630
50.0	300	280	250	240	220	195	120	110	700	520

► Pour les types long et extra-long, l'avance peut être réduite d'environ 50%



R.P.M. = tours/minute
Avance = mm/minute

HSS-E, 1 DENT

réf. C705, C706

Matière Usinée	Aluminium Aluminium allié	
	DIAMETRE	RPM
3.0	20000	1100
4.0	18000	950
5.0	14000	750
6.0	11000	600
7.0	10000	550
8.0	8500	450
10.0	7000	380

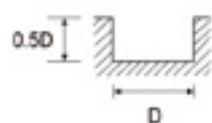

(jusqu'à Ø3:0.2D)

R.P.M. = tours/minute
Avance = mm/minute



corai
Outils coupants

FORETS

FRAISES

TARAUDS



corai

FRAISES HSSCo CÔNE MORSE

		LISTE DES MATIÈRES										
		aciers jusqu'à HB325	aciers jusqu'à 40HRC	aciers jusqu'à 45HRC	aciers INOX	fontes	Cuivre	Titane	Inconel	ALU	plastiques	
C740	Fraises HSSCo8, Cône Morse finition multi-dents DIN 845 série normale		p. 136	●	●						●	
C741	Fraises HSSCo8, Cône Morse ébauche multi-dents DIN 845 série normale pas grossiers		p. 137	●	●						●	

● utilisation conseillée pour la matière concernée.

DONNÉES TECHNIQUES

Conditions de coupe recommandées

page 138

FRAISES HSSCo8, CÔNE MORSE FINITION MULTI-DENTS DIN 845 SÉRIE NORMALE



réf. C740

conditions de coupe recommandées p. 138

Ø fraissage	Dimensions	Réf.	Prix unitaire TARIF H.T.
4 dents			
14.0	14xMT#2x26x111	C740 1400 T	58.84 €
15.0	15xMT#2x26x111	C740 1500 T	58.84 €
16.0	16xMT#2x32x117	C740 1600 T	58.84 €
18.0	18xMT#2x32x117	C740 1800 T	63.51 €
20.0	20xMT#2x38x123	C740 2000 T	66.09 €
6 dents			
22.0	22xMT#2x38x123	C740 2200 T	82.73 €
24.0	24xMT#3x45x147	C740 2400 T	111.94 €
25.0	25xMT#3x45x147	C740 2500 T	111.94 €
26.0	26xMT#3x45x147	C740 2600 T	125.64 €
28.0	28xMT#3x45x147	C740 2800 T	136.24 €
30.0	30xMT#3x45x147	C740 3000 T	148.26 €
32.0	32xMT#4x53x178	C740 3200 T	170.90 €
35.0	35xMT#4x53x178	C740 3500 T	226.94 €
36.0	36xMT#4x53x178	C740 3600 T	233.63 €
38.0	38xMT#4x63x188	C740 3800 T	266.21 €
40.0	40xMT#4x63x188	C740 4000 T	263.48 €
42.0	42xMT#4x63x188	C740 4200 T	307.79 €
44.0	44xMT#4x63x188	C740 4400 T	304.64 €
8 dents			
45.0	45xMT#4x63x188	C740 4500 T	304.64 €
50.0	50xMT#5x75x233	C740 5000 T	444.81 €

tolérance Ø fraises (mm)
±0.120

FRAISES HSSCo8, CÔNE MORSE ÉBAUCHE MULTI-DENTS DIN 845 SÉRIE NORMALE PAS GROSSIERS



réf. C741

conditions de coupe recommandées p. 138

Ø fraise	Dimensions	Réf.	Prix unitaire TARIF H.T.
4 dents			
14.0	14xMT#2x26x111	C741 1400 T	62.31 €
16.0	16xMT#2x32x117	C741 1600 T	64.29 €
18.0	18xMT#2x32x117	C741 1800 T	66.16 €
20.0	20xMT#2x38x123	C741 2000 T	71.47 €
5 dents			
22.0	22xMT#2x38x123	C741 2200 T	93.91 €
24.0	24xMT#3x45x147	C741 2400 T	112.50 €
25.0	25xMT#3x45x147	C741 2500 T	119.05 €
26.0	26xMT#3x45x147	C741 2600 T	142.97 €
6 dents			
27.0	27xMT#3x45x147	C741 2700 T	148.26 €
28.0	28xMT#3x45x147	C741 2800 T	148.26 €
30.0	30xMT#3x45x147	C741 3000 T	175.02 €
32.0	32xMT#4x53x178	C741 3200 T	192.83 €
35.0	35xMT#4x53x178	C741 3500 T	273.20 €
36.0	36xMT#4x53x178	C741 3600 T	266.21 €
38.0	38xMT#4x63x188	C741 3800 T	287.18 €
40.0	40xMT#4x63x188	C741 4000 T	283.75 €
45.0	45xMT#4x63x188	C741 4500 T	350.26 €
50.0	50xMT#5x75x233	C741 5000 T	504.24 €

tolérance Ø fraises (mm)
±0.120

HSSCo8, MULTI DENTS – USINAGE LATÉRAL

ref. C740

Matière Usinée	Aciers carbone Aciers alliés Aciers à outil		Aciers carbone Aciers alliés Aciers à outil		Aciers carbone Aciers alliés Aciers à outil		Aciers carbone Aciers alliés Aciers à outil		Aluminium Aluminium allié	
DURETÉ			~ HRc20		HRc20 ~ HRc30		HRc30 ~ HRc40			
RESISTANCE	~ 500N/mm ²		500 ~ 800N/mm ²		800 ~ 1000N/mm ²		1000 ~ 1300N/mm ²			
DIAMETRE	RPM	Avance	RPM	Avance	RPM	Avance	RPM	Avance	RPM	Avance
14.0	800	220	700	160	560	120	350	75	2200	530
16.0	700	220	560	160	450	105	280	65	2000	530
18.0	630	200	500	160	400	105	250	65	1800	530
20.0	560	200	450	160	400	105	220	65	1600	480
22.0	500	200	450	160	350	105	220	65	1400	450
25.0	450	180	400	145	310	90	180	50	1200	420
28.0	400	160	350	125	280	80	160	45	1100	400
30.0	350	140	310	110	250	75	160	45	1100	400
32.0	350	140	280	100	220	65	140	45	1000	360
36.0	310	120	250	90	200	60	120	35	900	330
40.0	280	120	220	90	180	60	110	35	800	300



R.P.M. = tours/minute
Avance = mm/minute

► Pour les types long et extra-long, l'avance peut être réduite d'environ 50%

HSSCo8, MULTI DENTS ÉBAUCHE – USINAGE LATÉRAL

ref. C741

Matière Usinée	Aciers carbone Aciers alliés Aciers à outil		Aciers carbone Aciers alliés Aciers à outil		Aciers carbone Aciers alliés Aciers à outil		Aciers carbone Aciers alliés Aciers à outil		Aluminium Aluminium allié	
DURETÉ			~ HRc20		HRc20 ~ HRc30		HRc30 ~ HRc40			
RESISTANCE	~ 500N/mm ²		500 ~ 800N/mm ²		800 ~ 1000N/mm ²		1000 ~ 1300N/mm ²			
DIAMETRE	RPM	Avance	RPM	Avance	RPM	Avance	RPM	Avance	RPM	Avance
14.0	800	180	700	140	560	110	350	70	1800	420
16.0	700	180	560	140	450	110	280	70	1600	450
18.0	630	180	500	140	400	110	250	70	1400	470
20.0	560	180	450	140	400	110	220	70	1200	500
22.0	500	220	450	170	350	140	220	85	1100	470
25.0	450	220	400	170	310	140	180	85	1000	450
28.0	400	210	350	160	280	130	160	85	900	510
30.0	350	210	310	160	250	130	160	85	900	530
32.0	350	210	280	160	220	130	140	85	800	500
36.0	310	210	250	160	200	130	120	85	700	470
40.0	280	200	220	150	180	120	110	80	630	450
50.0	220	200	180	170	160	140	90	80	500	370



R.P.M. = tours/minute
Avance = mm/minute

► Pour les types long et extra-long, l'avance peut être réduite d'environ 50%

AUTRES PRODUITS DE FRAISAGE

		LISTE DES MATIÈRES					
		aciers carbone jusqu'à 900 N/mm ²	aciers alliés jusqu'à 1 300 N/mm ²	aciers INOX jusqu'à 1 300 N/mm ²	ALU		
C780 C781	Fraise HSS-E pour queue d'aronde type «A», «C», «E» à méplat		p. 140	•	•		
C782 C783	Fraise HSS-E pour queue d'aronde type «B», «D», «F» à méplat		p. 141	•	•		
C784	Fraise HSS-E Woodruff type «B», «D», «F» à méplat		p. 142	•	•		
C785	Fraise HSS-E à «T» à méplat		p. 143	•	•		
C786	Fraise HSS-E 3 tailles, denture droite		p. 144	•	•		
C787	Fraise HSS-E 3 tailles, denture alternée		p. 145	•	•		
C788	Fraise HSSCo8, 2 tailles, trou lisse finition		p. 148	•	•		
C789	Fraise HSSCo8, 2 tailles trou lisse finition ALUMINIUM		p. 148				•
C790	Fraise HSSCo8, 2 tailles trou lisse ébauche pas grossiers		p. 149	•	•		
C791	Fraise HSSCo8, 2 tailles trou lisse ébauche pas fins		p. 149	•	•		
C792	Fraise HSSCo8, 2 tailles trou lisse semi-finition		p. 150	•	•		
C793	Fraise HSSCo8, 1/4 de cercle, 4 dents		p. 150	•	•		
Z156	Fraise HSSCo8, 90° à ébavurer, 3 dents		p. 151	•	•	•	•

• utilisation conseillée pour la matière concernée.

DONNÉES TECHNIQUES

Conditions de coupe recommandées
pages 152 à 157

FRAISE HSS-E POUR QUEUE D'ARONDE TYPE «A», «C», «E» À MÉPLAT

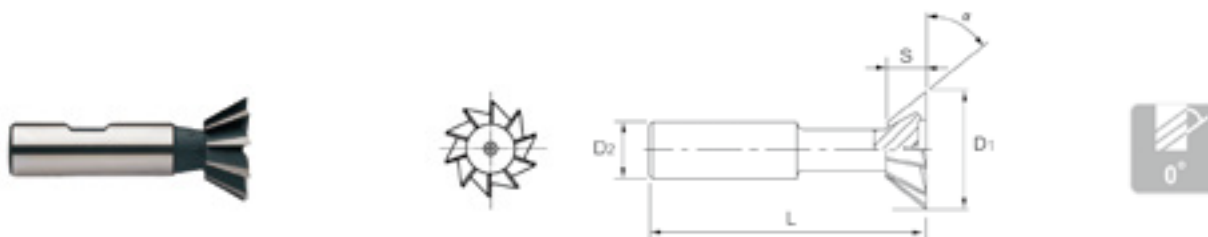

réf. C780

conditions de coupe recommandées p. 152

α ($\pm 15'$) à 45°

\emptyset fraisage	Dimensions	Nombre de dents	Réf.	Prix unitaire TARIF H.T.
	D1xD2xSxL			
16.0	16x12x4x60	6	C780 0160 M	32.17 €
20.0	20x12x5x63	6	C780 0200 M	40.78 €
22.0	22x12x6x67	6	C780 0220 M	59.05 €
25.0	25x16x6.3x67	8	C780 0250 M	60.52 €
28.0	28x16x7.5x67	8	C780 0280 M	67.22 €
32.0	32x16x8x71	10	C780 0320 M	73.90 €
38.0	38x16x10x80	12	C780 0380 M	109.01 €

réf. C781

conditions de coupe recommandées p. 152

α ($\pm 15'$) à 60°

\emptyset fraisage	Dimensions	Nombre de dents	Réf.	Prix unitaire TARIF H.T.
	D1xD2xSxL			
16.0	16x12x6.3x60	6	C781 0160 M	32.17 €
20.0	20x12x8x63	6	C781 0200 M	40.78 €
22.0	22x12x9x67	6	C781 0220 M	59.05 €
25.0	25x16x10x67	8	C781 0250 M	60.52 €
28.0	28x16x11x67	8	C781 0280 M	67.22 €
32.0	32x16x12.5x71	10	C781 0320 M	73.90 €
38.0	38x16x16x80	12	C781 0380 M	109.01 €
40.0	40x25x13x85	12	C781 0400 M	125.00 €
50.0	50x25x16x100	16	C781 0500 M	253.55 €

Tolérances selon DIN 7160 & 7161

Diamètre nominal en mm							
	plus de 3 à 6	plus de 6 à 10	plus de 10 à 18	plus de 18 à 30	plus de 30 à 50	plus de 50 à 80	plus de 80 à 120
Plage de tolérance en mm							
js16	± 0.375	± 0.45	± 0.55	± 0.65	± 0.80	± 0.95	± 1.10
js14	± 0.15	± 0.18	± 0.215	± 0.26	± 0.31	± 0.37	± 0.435
js18	± 0.90	± 1.1	± 1.35	± 1.65	± 1.95	± 2.30	± 2.70
Plage de tolérance en μm							
h6	0 - 8	0 - 9	0 - 11	0 - 13	0 - 16	0 - 19	0 - 22

FRAISE HSS-E POUR QUEUE D'ARONDE TYPE «B», «D», «F» À MÉPLAT

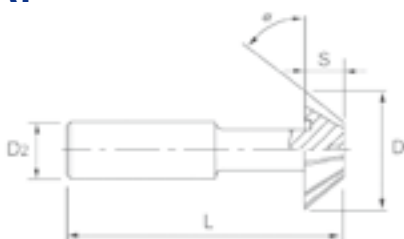

réf. C782

conditions de coupe recommandées p. 152

$\alpha (\pm 15') \text{ à } 45^\circ$

Ø fraisage	Dimensions	Nombre de dents	Réf.	Prix unitaire TARIF H.T.
	D1xD2xSxL			
16.0	16x12x4x60	6	C782 0160 M	32.17 €
20.0	20x12x5x63	6	C782 0200 M	40.78 €
22.0	22x12x6x67	6	C782 0220 M	59.05 €
25.0	25x16x6.3x67	8	C782 0250 M	60.52 €
28.0	28x16x7.5x67	8	C782 0280 M	67.22 €
32.0	32x16x8x71	10	C782 0320 M	73.90 €
38.0	38x16x10x80	12	C782 0380 M	109.01 €

réf. C783

conditions de coupe recommandées p. 152

$\alpha (\pm 15') \text{ à } 60^\circ$

Ø fraisage	Dimensions	Nombre de dents	Réf.	Prix unitaire TARIF H.T.
	D1xD2xSxL			
16.0	16x12x6.3x60	6	C783 0160 M	32.17 €
20.0	20x12x8x63	6	C783 0200 M	40.78 €
22.0	22x12x9x67	6	C783 0220 M	59.05 €
25.0	25x16x10x67	8	C783 0250 M	60.52 €
28.0	28x16x11x67	8	C783 0280 M	67.22 €
32.0	32x16x12.5x71	10	C783 0320 M	73.90 €
38.0	38x16x16x80	12	C783 0380 M	109.01 €

Tolérances selon DIN 7160 & 7161

Diamètre nominal en mm						
	plus de 3 à 6	plus de 6 à 10	plus de 10 à 18	plus de 18 à 30	plus de 30 à 50	plus de 50 à 80
Plage de tolérance en mm						
js16	± 0.375	± 0.45	± 0.55	± 0.65	± 0.80	± 0.95
js14	± 0.15	± 0.18	± 0.215	± 0.26	± 0.31	± 0.37
js18	± 0.90	± 1.1	± 1.35	± 1.65	± 1.95	± 2.30
Plage de tolérance en µm						
h6	0 - 8	0 - 9	0 - 11	0 - 13	0 - 16	0 - 19

FRAISE HSS-E WOODRUFF TYPE «B», «D», «F» À MÉPLAT

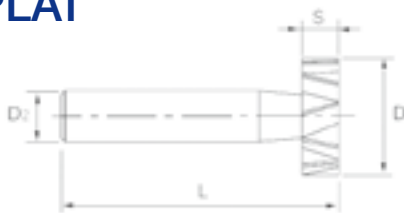

réf. C784

conditions de coupe recommandées p. 153

Ø fraisage	Dimensions	Nombre de dents	Réf.	Prix unitaire TARIF H.T.
	D1xD2xSxL			
10.5	10.5x6x2x50	8	C784 0105 01 M	26.83 €
10.5	10.5x6x2.5x50	8	C784 0105 02 M	26.83 €
10.5	10.5x6x3x50	8	C784 0105 03 M	26.83 €
13.5	13.5x10x2x56	8	C784 0135 01 M	31.09 €
13.5	13.5x10x2.5x56	8	C784 0135 02 M	31.09 €
13.5	13.5x10x3x56	8	C784 0135 03 M	31.09 €
13.5	13.5x10x4x56	8	C784 0135 04 M	31.09 €
16.5	16.5x10x2.5x56	8	C784 0165 01 M	33.94 €
16.5	16.5x10x3x56	8	C784 0165 02 M	33.94 €
16.5	16.5x10x4x56	8	C784 0165 03 M	33.94 €
16.5	16.5x10x5x56	8	C784 0165 04 M	33.94 €
19.5	19.5x10x3x56	8	C784 0195 01 M	43.31 €
19.5	19.5x10x4x63	8	C784 0195 02 M	43.31 €
19.5	19.5x10x5x63	8	C784 0195 03 M	43.31 €
19.5	19.5x10x6x63	8	C784 0195 04 M	43.31 €
22.5	22.5x10x4x63	10	C784 0225 01 M	46.32 €
22.5	22.5x10x5x63	10	C784 0225 02 M	46.32 €
22.5	22.5x10x6x63	10	C784 0225 03 M	46.32 €
22.5	22.5x10x8x63	10	C784 0225 04 M	46.32 €
25.5	25.5x10x5x63	10	C784 0255 01 M	58.55 €
25.5	25.5x10x6x63	10	C784 0255 02 M	58.55 €
25.5	25.5x10x7x63	10	C784 0255 03 M	58.55 €
25.5	25.5x10x8x63	10	C784 0255 04 M	58.55 €
28.5	28.5x10x5x63	10	C784 0285 01 M	63.70 €
28.5	28.5x10x6x63	10	C784 0285 02 M	63.70 €
28.5	28.5x10x7x63	10	C784 0285 03 M	63.70 €
28.5	28.5x10x8x63	10	C784 0285 04 M	63.70 €
28.5	28.5x12x10x71	10	C784 0285 05 M	63.70 €
32.5	32.5x12x5x71	12	C784 0325 01 M	70.08 €
32.5	32.5x12x6x71	12	C784 0325 02 M	70.08 €
32.5	32.5x12x7x71	12	C784 0325 03 M	70.08 €
32.5	32.5x12x8x71	12	C784 0325 04 M	70.08 €
32.5	32.5x12x10x71	12	C784 0325 05 M	70.08 €
38.5	38.5x12x7x71	12	C784 0385 01 M	103.02 €
38.5	38.5x12x8x71	12	C784 0385 02 M	103.02 €
38.5	38.5x12x9x71	12	C784 0385 03 M	103.02 €
38.5	38.5x12x10x71	12	C784 0385 04 M	103.02 €
45.5	45.5x12x10x71	14	C784 0455 01 M	125.76 €

Tolérances selon DIN 7160 & 7161

	Diamètre nominal en mm						
	plus de 1 à 3	plus de 3 à 6	plus de 6 à 10	plus de 10 à 18	plus de 18 à 30	plus de 30 à 50	plus de 50 à 80
	Plage de tolérance en mm						
js18	-	± 0.90	± 1.10	± 1.35	± 1.65	± 1.95	± 2.30
	Plage de tolérance en µm						
h11	0 -60	0 -75	0 -90	0 -110	0 -130	0 -160	0 -190
e8	-14 -28	-20 -38	-25 -47	-32 -59	-40 -73	-50 -89	-60 -166
h6	0 -6	0 -8	0 -9	0 -11	0 -13	0 -16	0 -19

FRAISE HSS-E À «T» À MÉPLAT

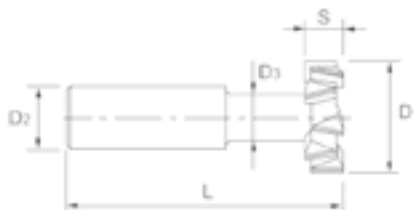

réf. C785

conditions de coupe recommandées p. 153

Ø fraisage	Dimensions	Nombre de dents	Réf.	Prix unitaire TARIF H.T.
	D1xD2xD3xSxL			
12.5	12.5x10x5x6x57	6	C785 0125 M	30.96 €
16.0	16x10x6.5x8x62	6	C785 0160 M	39.05 €
18.0	18x12x8x8x70	6	C785 0180 M	40.95 €
19.0	19x12x8x9x71	6	C785 0190 M	43.01 €
21.0	21x12x10x9x74	6	C785 0210 M	53.27 €
22.0	22x12x10x10x75	6	C785 0220 M	55.94 €
25.0	25x16x12x11x82	6	C785 0250 M	67.40 €
28.0	28x16x13x12x83	6	C785 0280 M	75.11 €
32.0	32x16x15x14x90	8	C785 0320 M	80.47 €
36.0	36x25x17x16x103	8	C785 0360 M	114.62 €
40.0	40x25x19x18x108	8	C785 0400 M	145.50 €

Tolérances selon DIN 7160 & 7161

Diamètre nominal en mm							
	plus de 3 à 6	plus de 6 à 10	plus de 10 à 18	plus de 18 à 30	plus de 30 à 50	plus de 50 à 80	plus de 80 à 120
Plage de tolérance en mm							
h12	0 - 0.12	0 - 0.15	0 - 0.18	0 - 0.21	0 - 0.25	0 - 0.30	0 - 0.35
js18	± 0.90	± 1.10	± 1.35	± 1.65	± 1.95	± 2.30	± 2.70
Plage de tolérance en µm							
d11	-30 -105	-40 -130	-50 -160	-65 -195	-80 -240	-100 -290	-120 -340
h6	0 -8	0 -9	0 -11	0 -13	0 -16	0 -19	0 -22

FRAISE HSS-E 3 TAILLES, DENTURE DROITE

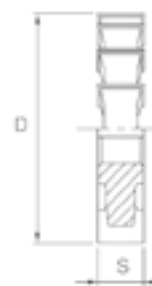

réf. C786

conditions de coupe recommandées p. 154

Ø fraisage	Dimensions	Nombre de dents	Réf.	Prix unitaire TARIF H.T.
	DxSxd			
50.0	50x4x16	18	C786 0500 01	74.98 €
50.0	50x5x16	18	C786 0500 02	74.98 €
50.0	50x6x16	18	C786 0500 03	74.98 €
50.0	50x8x16	16	C786 0500 04	78.31 €
50.0	50x10x16	16	C786 0500 05	86.91 €
63.0	63 x 5 x 22	22	C786 0630 01	87.53 €
63.0	63x6x22	22	C786 0630 02	87.53 €
63.0	63x8x22	20	C786 0630 03	90.85 €
63.0	63x10x22	20	C786 0630 04	103.26 €
63.0	63x12x22	20	C786 0630 05	116.46 €
80.0	80x6x22	24	C786 0800 01	107.28 €
80.0	80x8x22	24	C786 0800 02	118.42 €
80.0	80x10x22	24	C786 0800 03	123.73 €
80.0	80x12x22	20	C786 0800 04	131.62 €
80.0	80x6x27	24	C786 0800 05	107.28 €
80.0	80x8x27	24	C786 0800 06	118.42 €
80.0	80x10x27	24	C786 0800 07	123.73 €
80.0	80x12x27	20	C786 0800 08	131.62 €
100.0	100x6x27	26	C786 1000 01	146.07 €
100.0	100x8x27	26	C786 1000 02	154.68 €
100.0	100x10x27	22	C786 1000 03	168.44 €
100.0	100x6x32	26	C786 1000 04	146.07 €
100.0	100x8x32	26	C786 1000 05	154.68 €
100.0	100x10x32	22	C786 1000 06	168.44 €
100.0	100x12x32	22	C786 1000 07	182.26 €
125.0	125x8x32	30	C786 1250 01	198.44 €
125.0	125x10x32	30	C786 1250 02	221.12 €
125.0	125x12x32	24	C786 1250 03	232.71 €

Tolérances selon DIN 7160 & 7161

Diamètre nominal en mm								
	plus de 3 à 6	plus de 6 à 10	plus de 10 à 18	plus de 18 à 30	plus de 30 à 50	plus de 50 à 80	plus de 80 à 120	plus de 120 à 180
Plage de tolérance en mm								
js14	± 0.15	± 0.18	± 0.215	± 0.26	± 0.31	± 0.37	± 0.435	± 0.50
Plage de tolérance en µm								
k11	+ 75 0	+90 0	+ 110 0	+ 130 0	+ 160 0	+ 190 0	+ 220 0	+ 250 0
H7	+ 12 0	+ 15 0	+ 18 0	+ 21 0	+25 0	+ 30 0	+ 35 0	+ 40 0

FRAISE HSS-E 3 TAILLES, DENTURE ALTERNÉE

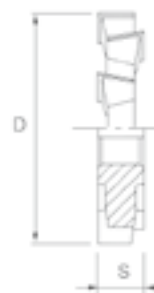

réf. C787

conditions de coupe recommandées p. 154

Ø fraisage	Dimensions	Nombre de dents	Réf.	Prix unitaire TARIF H.T.
	DxSxd			
50.0	50x3x16	14	C787 0500 01	70.59 €
50.0	50x4x16	14	C787 0500 02	62.05 €
50.0	50x5x16	14	C787 0500 03	62.05 €
50.0	50x6x16	14	C787 0500 04	62.05 €
50.0	50x7x16	14	C787 0500 05	62.05 €
50.0	50x8x16	14	C787 0500 06	65.75 €
50.0	50x9x16	14	C787 0500 07	68.80 €
50.0	50x10x16	14	C787 0500 08	68.80 €
63.0	63x3x22	16	C787 0630 01	89.63 €
63.0	63x4x22	16	C787 0630 02	73.65 €
63.0	63x5x22	16	C787 0630 03	73.65 €
63.0	63 x 6 x 22	16	C787 0630 04	73.65 €
63.0	63x7x22	16	C787 0630 05	76.20 €
63.0	63x8x22	16	C787 0630 06	76.20 €
63.0	63x9x22	16	C787 0630 07	78.04 €
63.0	63x10x22	16	C787 0630 08	86.65 €
63.0	63x12x22	16	C787 0630 09	90.34 €
63.0	63x14x22	16	C787 0630 10	96.41 €
63.0	63x16x22	16	C787 0630 11	103.19 €
63.0	63x18x22	16	C787 0630 12	108.12 €
80.0	80x3x22	18	C787 0800 01	106.26 €
80.0	80x4x22	18	C787 0800 02	87.21 €
80.0	80 x 5 x 22	18	C787 0800 03	87.21 €
80.0	80x6x22	18	C787 0800 04	87.21 €
80.0	80x7x22	18	C787 0800 05	97.09 €
80.0	80x8x22	18	C787 0800 06	97.09 €
80.0	80x9x22	18	C787 0800 07	106.84 €
80.0	80x10x22	18	C787 0800 08	106.84 €
80.0	80x12x22	18	C787 0800 09	112.38 €
80.0	80x14x22	18	C787 0800 10	119.75 €
80.0	80x16x22	18	C787 0800 11	129.02 €
80.0	80x18x22	18	C787 0800 12	135.13 €
80.0	80x20x22	18	C787 0800 13	143.71 €
80.0	80x4x27	18	C787 0800 14	87.21 €
80.0	80x5x27	18	C787 0800 15	87.21 €

suite page suivante

Tolérances selon DIN 7160 & 7161

Diamètre nominal en mm									
	plus de 3 à 6	plus de 6 à 10	plus de 10 à 18	plus de 18 à 30	plus de 30 à 50	plus de 50 à 80	plus de 80 à 120	plus de 120 à 180	plus de 180 à 250
Plage de tolérance en mm									
js14	± 0.15	± 0.18	± 0.215	± 0.26	± 0.31	± 0.37	± 0.435	± 0.50	± 0.575
Plage de tolérance en µm									
k11	+ 75 0	+90 0	+ 110 0	+ 130 0	+ 160 0	+ 190 0	+ 220 0	+ 250 0	+ 290 0
H7	+ 12 0	+ 15 0	+ 18 0	+ 21 0	+25 0	+ 30 0	+ 35 0	+ 40 0	+ 46 0

FRAISE HSS-E 3 TAILLES, DENTURE ALTERNÉE

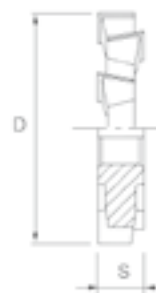

réf. C787 suite

conditions de coupe recommandées p. 154

Ø fraise	Dimensions	Nombre de dents	Réf.	Prix unitaire TARIF H.T.
	DxSxd			
80.0	80x6x27	18	C787 0800 16	87.21 €
80.0	80x7x27	18	C787 0800 17	97.09 €
80.0	80x8x27	18	C787 0800 18	97.09 €
80.0	80x9x27	18	C787 0800 19	106.84 €
80.0	80x10x27	18	C787 0800 20	106.84 €
80.0	80x12x27	18	C787 0800 21	112.38 €
80.0	80x14x27	18	C787 0800 22	119.75 €
80.0	80x16x27	18	C787 0800 23	129.02 €
80.0	80x18x27	18	C787 0800 24	135.13 €
80.0	80x20x27	18	C787 0800 25	143.71 €
100.0	100x3x27	20	C787 1000 01	145.50 €
100.0	100x4x27	20	C787 1000 02	119.75 €
100.0	100x5x27	20	C787 1000 03	119.75 €
100.0	100x6x27	20	C787 1000 04	119.75 €
100.0	100x7x27	20	C787 1000 05	119.75 €
100.0	100x8x27	20	C787 1000 06	133.91 €
100.0	100x9x27	20	C787 1000 07	133.91 €
100.0	100x10x27	20	C787 1000 08	141.29 €
100.0	100x12x27	20	C787 1000 09	156.66 €
100.0	100x14x27	20	C787 1000 10	160.85 €
100.0	100x16x27	20	C787 1000 12	179.96 €
100.0	100x18x27	20	C787 1000 13	187.29 €
100.0	100x20x27	20	C787 1000 14	200.81 €
100.0	100x4x32	20	C787 1000 15	119.75 €
100.0	100x5x32	20	C787 1000 16	119.75 €
100.0	100x6x32	20	C787 1000 17	119.75 €
100.0	100x7x32	20	C787 1000 18	119.75 €
100.0	100x8x32	20	C787 1000 19	133.91 €
100.0	100x9x32	20	C787 1000 20	133.91 €
100.0	100x10x32	20	C787 1000 21	141.29 €
100.0	100x12x32	20	C787 1000 22	156.66 €
100.0	100x14x32	20	C787 1000 23	160.85 €
100.0	100x16x32	20	C787 1000 25	179.96 €
100.0	100x18x32	20	C787 1000 26	187.29 €
100.0	100x20x32	20	C787 1000 27	200.81 €

suite page suivante

Tolérances selon DIN 7160 & 7161

Diamètre nominal en mm									
	plus de 3 à 6	plus de 6 à 10	plus de 10 à 18	plus de 18 à 30	plus de 30 à 50	plus de 50 à 80	plus de 80 à 120	plus de 120 à 180	plus de 180 à 250
Plage de tolérance en mm									
js14	± 0.15	± 0.18	± 0.215	± 0.26	± 0.31	± 0.37	± 0.435	± 0.50	± 0.575
Plage de tolérance en µm									
k11	+ 75 0	+90 0	+ 110 0	+ 130 0	+ 160 0	+ 190 0	+ 220 0	+ 250 0	+ 290 0
H7	+ 12 0	+ 15 0	+ 18 0	+ 21 0	+25 0	+ 30 0	+ 35 0	+ 40 0	+ 46 0

FRAISE HSS-E 3 TAILLES, DENTURE ALTERNÉE

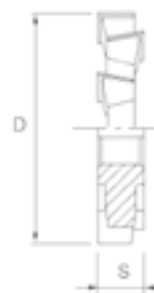

réf. C787 suite

conditions de coupe recommandées p. 154

Ø fraisage	Dimensions	Nombre de dents	Réf.	Prix unitaire TARIF H.T.
	DxSxd			
125.0	125x5x32	22	C787 1250 01	170.10 €
125.0	125x6x32	22	C787 1250 02	170.10 €
125.0	125x8x32	22	C787 1250 03	174.43 €
125.0	125x10x32	22	C787 1250 04	195.31 €
125.0	125x12x32	22	C787 1250 05	205.15 €
125.0	125x14x32	22	C787 1250 06	218.65 €
125.0	125x16x32	22	C787 1250 07	241.96 €
125.0	125x18x32	22	C787 1250 08	259.15 €
125.0	125x20x32	22	C787 1250 09	276.99 €
160.0	160x6x32	26	C787 1600 01	245.02 €
160.0	160x8x32	26	C787 1600 02	261.64 €
160.0	160x10x32	26	C787 1600 03	283.75 €
160.0	160x12x32	26	C787 1600 04	305.22 €
160.0	160x14x32	26	C787 1600 05	330.44 €
160.0	160x16x32	26	C787 1600 06	350.71 €
160.0	160x18x32	26	C787 1600 07	380.77 €
160.0	160x20x32	26	C787 1600 08	412.05 €
160.0	160x6x40	26	C787 1600 09	245.02 €
160.0	160x8x40	26	C787 1600 10	261.64 €
160.0	160x10x40	26	C787 1600 11	283.75 €
160.0	160x12x40	26	C787 1600 12	305.22 €
160.0	160x14x40	26	C787 1600 13	330.44 €
160.0	160x16x40	26	C787 1600 14	350.71 €
160.0	160x18x40	26	C787 1600 15	380.77 €
160.0	160x20x40	26	C787 1600 16	412.05 €
200.0	200x10x40	30	C787 2000 01	474.17 €
200.0	200x12x40	30	C787 2000 02	504.80 €
200.0	200x14x40	30	C787 2000 03	526.34 €
200.0	200x16x40	30	C787 2000 04	566.92 €
200.0	200x18x40	30	C787 2000 05	603.67 €
200.0	200x20x40	30	C787 2000 06	650.43 €
200.0	200x22x40	30	C787 2000 07	737.01 €
200.0	200x25x40	30	C787 2000 08	760.33 €

Tolérances selon DIN 7160 & 7161

Diamètre nominal en mm									
	plus de 3 à 6	plus de 6 à 10	plus de 10 à 18	plus de 18 à 30	plus de 30 à 50	plus de 50 à 80	plus de 80 à 120	plus de 120 à 180	plus de 180 à 250
Plage de tolérance en mm									
js14	± 0.15	± 0.18	± 0.215	± 0.26	± 0.31	± 0.37	± 0.435	± 0.50	± 0.575
Plage de tolérance en µm									
k11	+ 75 0	+90 0	+ 110 0	+ 130 0	+ 160 0	+ 190 0	+ 220 0	+ 250 0	+ 290 0
H7	+ 12 0	+ 15 0	+ 18 0	+ 21 0	+25 0	+ 30 0	+ 35 0	+ 40 0	+ 46 0

FRAISE HSSCo8, 2 TAILLES, TROU LISSE FINITION

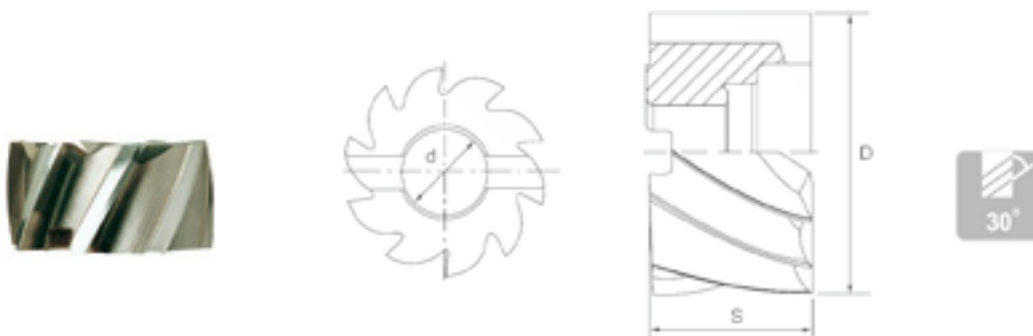

réf. C788

conditions de coupe recommandées p. 155

Ø fraisage	Dimensions	Nombre de dents	Réf.	Prix unitaire TARIF H.T.
	DxSxd			
40.0	40x32x16*	8	C788 40001	87.15 €
50.0	50x36x22	8	C788 50001	121.81 €
63.0	63x40x27	8	C788 6300	167.10 €
80.0	80x45x27	10	C788 8000	276.99 €
100.0	100x50x32	10	C788 A000	467.02 €
125.0	125x56x40	12	C788 C500	700.89 €
160.0	160x63x50	14	C788 G000	1 278.11 €

Tolérance Ø de fraise (mm)	Tolérance largeur de face (mm)	Tolérance Ø interne (mm)
+ 0.25 - 0.15	+ 0.5 - 0	+ 0.02 - 0

* Tolérance sur diamètre interne = +0.018 ~ 0

FRAISE HSSCo8, 2 TAILLES TROU LISSE FINITION ALUMINIUM

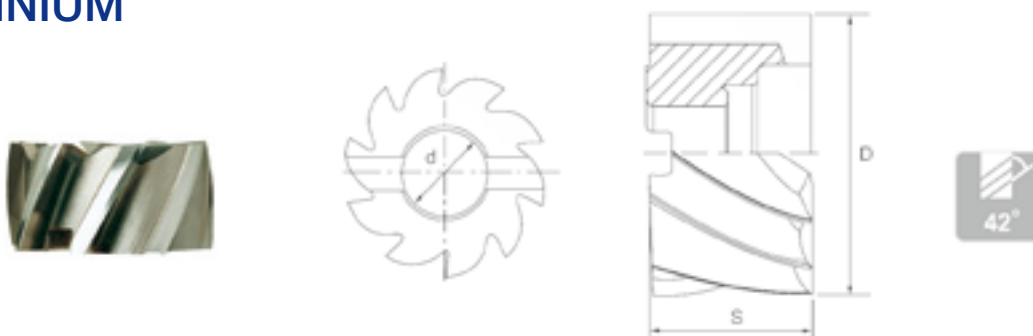

réf. C789

conditions de coupe recommandées p. 155

Ø fraisage	Dimensions	Nombre de dents	Réf.	Prix unitaire TARIF H.T.
	DxSxd			
40.0	40x32x16*	4	C789 40001	91.42 €
50.0	50x36x22	6	C789 50001	130.06 €
63.0	63x40x27	6	C789 6300	178.58 €
80.0	80x45x27	6	C789 8000	318.59 €
100.0	100x50x32	6	C789 A000	567.50 €

Tolérance Ø de fraise (mm)	Tolérance largeur de face (mm)	Tolérance Ø interne (mm)
+ 0.25 - 0.15	+ 0.5 - 0	+ 0.02 - 0

* Tolérance sur diamètre interne = +0.018 ~ 0

FRAISE HSSCo8, 2 TAILLES TROU LISSE ÉBAUCHE PAS GROSSIERS

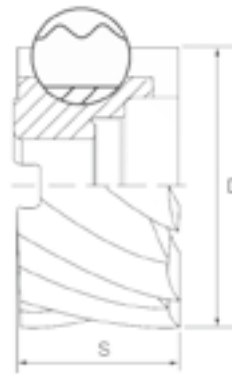

réf. C790

conditions de coupe recommandées p. 156

Ø fraisage	Dimensions	Nombre de dents	Réf.	Prix unitaire TARIF H.T.
	DxSxd			
40.0	40x32x16*	6	C790 4000	100.97 €
50.0	50x36x22	8	C790 5000	135.20 €
63.0	63x40x27	8	C790 6300	195.39 €
80.0	80x45x27	10	C790 8000	316.75 €
100.0	100x50x32	10	C790 A000	496.98 €
125.0	125x56x40	12	C790 C500	753.69 €
160.0	160x63x50	12	C790 G000	1 309.35 €

Tolérance Ø de fraise (mm)	Tolérance largeur de face (mm)	Tolérance Ø interne (mm)
+ 0.25 - 0.15	+ 0.5 - 0	+ 0.02 - 0

* Tolérance sur diamètre interne = +0.018 ~ 0

FRAISE HSSCo8, 2 TAILLES TROU LISSE ÉBAUCHE PAS FINS

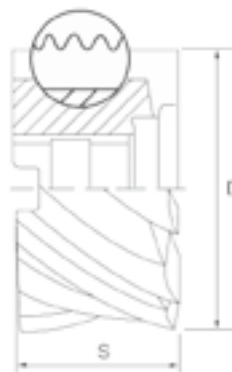

réf. C791

conditions de coupe recommandées p. 156

Ø fraisage	Dimensions	Nombre de dents	Réf.	Prix unitaire TARIF H.T.
	DxSxd			
40.0	40x32x16*	6	C791 4000	100.97 €
50.0	50x36x22	8	C791 5000	135.20 €
63.0	63x40x27	8	C791 6300	195.39 €
80.0	80x45x27	10	C791 8000	316.75 €
100.0	100x50x32	10	C791 A000	496.98 €
125.0	125x56x40	12	C791 C500	753.69 €
160.0	160x63x50	12	C791 G000	1 309.35 €

Tolérance Ø de fraise (mm)	Tolérance largeur de face (mm)	Tolérance Ø interne (mm)
+ 0.25 - 0.15	+ 0.5 - 0	+ 0.02 - 0

* Tolérance sur diamètre interne = +0.018 ~ 0

FRAISE HSSCo8, 2 TAILLES TROU LISSE SEMI-FINITION

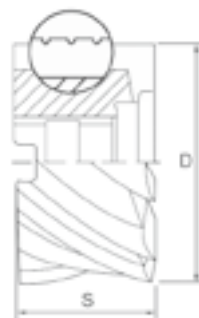

réf. C792

conditions de coupe recommandées p. 156

Ø fraise	Dimensions	Nombre de dents	Réf.	Prix unitaire TARIF H.T.
	DxSxd			
40.0	40x32x16*	6	C792 4000	111.04 €
50.0	50x36x22	8	C792 5000	148.62 €
63.0	63x40x27	8	C792 6300	215.01 €
80.0	80x45x27	10	C792 8000	348.40 €
100.0	100x50x32	10	C792 A000	546.60 €
125.0	125x56x40	12	C792 C500	829.08 €
160.0	160x63x50	12	C792 G000	1 440.37 €

Tolérance Ø de fraise (mm)	Tolérance largeur de face (mm)	Tolérance Ø interne (mm)
+ 0.25 - 0.15	+ 0.5 - 0	+ 0.02 - 0

* Tolérance sur diamètre interne = +0.018 ~ 0

FRAISE HSSCo8, 1/4 DE CERCLE, 4 DENTS



réf. C793

conditions de coupe recommandées p. 157

Ø de coupe	Dimensions	Réf.	Prix unitaire TARIF H.T.	Ø de coupe	Dimensions	Réf.	Prix unitaire TARIF H.T.
	RxDxD2xL				RxDxD2xL		
R1.0	R1.0x8x10x60	C793 0800 010 M	43.96 €	R8.5	R8.5x25x25x85	C793 2500 085 M	108.92 €
R1.5	R1.5x9x10x60	C793 0900 015 M	43.96 €	R9.0	R9.0x26x25x85	C793 2600 090 M	108.92 €
R2.0	R2.0x10x10x60	C793 1000 020 M	43.96 €	R9.5	R9.5x27x25x85	C793 2700 095 M	108.92 €
R2.5	R2.5x11x10x60	C793 1100 025 M	45.74 €	R10.0	R10.0x28x25x85	C793 2800 100 M	108.92 €
R3.0	R3.0x12x12x60	C793 1200 030 M	50.66 €	R10.5	R10.5x31x25x90	C793 3100 105 M	153.09 €
R3.5	R3.5x13x12x60	C793 1300 035 M	50.66 €	R11.0	R11x32x25x90	C793 3200 110 M	153.09 €
R4.0	R4.0x14x12x60	C793 1400 040 M	53.97 €	R12.0	R12.0x34x25x90	C793 3400 120 M	153.09 €
R4.5	R4.5x15x12x60	C793 1500 045 M	56.76 €	R12.5	R12.5x41x25x100	C793 4100 125 M	183.66 €
R5.0	R5.0x16x12x60	C793 1600 050 M	58.66 €	R13.0	R13x42x25x100	C793 4200 130 M	183.66 €
R5.5	R5.5x19x16x67	C793 1900 055 M	58.66 €	R14.0	R14x44x25x100	C793 4400 140 M	183.66 €
R6.0	R6.0x20x16x67	C793 2000 060 M	64.21 €	R15.0	R15x46x25x100	C793 4600 150 M	267.44 €
R6.5	R6.5x21x16x71	C793 2100 065 M	75.50 €	R16.0	R16x48x25x100	C793 4800 160 M	267.44 €
R7.0	R7.0x22x16x71	C793 2200 070 M	75.50 €	R18.0	R18x52x32x112	C793 5200 180 M	267.44 €
R7.5	R7.5x23x16x71	C793 2300 075 M	75.50 €	R20.0	R20x56x32x112	C793 5600 200 M	380.65 €
R8.0	R8.0x24x16x71	C793 2400 080 M	84.42 €				

Tolérances selon DIN 7160 & 7161

Diamètre nominal en mm						
	de 1 à 3	plus de 3 à 6	plus de 6 à 10	plus de 10 à 18	plus de 18 à 30	plus de 30 à 50
Plage de tolérance en µm						
H11	+ 60 0	+ 75 0	+ 90 0	+ 110 0	+ 130 0	+ 160 0
h6	0 - 6	0 - 8	0 - 9	0 - 11	0 - 13	0 - 16

FRAISE HSSCo8, 90° À ÉBAVURER 3 DENTS DIN 335 C

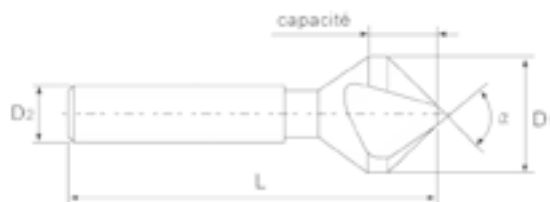

réf. Z156

conditions de coupe recommandées p. 157

Ø fraisage	Dimensions	Capacité	Réf.	Prix unitaire TARIF H.T.
	D1xD2xLxα			
4.3	4.3x4x40x90°	1.3 - 4.3	Z156 0430	13.46 €
5.0	5.0x4x40x90°	1.5 - 5	Z156 0500	13.46 €
6.0	6.0x5x45x90°	1.5 - 6	Z156 0600	13.46 €
6.3	6.3x5x45x90°	1.5 - 6.3	Z156 0630	13.46 €
7.0	7.0x6x50x90°	1.8 - 7	Z156 0700	15.42 €
8.0	8.0x6x50x90°	2 - 8	Z156 0800	15.42 €
8.3	8.3x6x50x90°	2 - 8.3	Z156 0830	15.42 €
10.0	10.0x6x50x90°	2.5 - 10	Z156 1000	18.29 €
10.4	10.4x6x50x90°	2.5 - 10.4	Z156 1040	18.29 €
11.5	11.5x8x56x90°	2.8 - 11.5	Z156 1150	21.21 €
12.4	12.4x8x56x90°	2.8 - 12.4	Z156 1240	21.21 €
15.0	15.0x10x60x90°	3.2 - 15	Z156 1500	23.73 €
16.5	16.5x10x60x90°	3.2 - 16.5	Z156 1650	23.73 €
19.0	19.0x10x63x90°	3.5 - 19	Z156 1900	35.22 €
20.5	20.5x10x63x90°	3.5 - 20.5	Z156 2050	35.22 €
23.0	23.0x10x67x90°	3.8 - 23	Z156 2300	50.89 €
25.0	25.0x10x67x90°	3.8 - 25	Z156 2500	50.89 €
30.0	30.0x12x71x90°	4.2 - 30	Z156 3000	71.41 €
31.0	31.0x12x71x90°	4.2 - 31	Z156 3100	71.41 €

tolérance Ø nominal (mm)	tolérance Ø attachement (mm)
±0.05	h9

HSS-E, FRAISE POUR QUEUE D'ARRONDE TYPE "A", "C", "E"

réf. C780, C781

Matière Usinée	Aciers carbone Aciers alliés		Aciers carbone Aciers alliés Aciers à outil		Aciers carbone Aciers alliés Aciers à outil		Aciers carbone Aciers alliés Aciers à outil		Aluminium Aluminium allié	
	DURETÉ	RESISTANCE	DURETÉ	RESISTANCE	DURETÉ	RESISTANCE	DURETÉ	RESISTANCE	DURETÉ	RESISTANCE
DIAMETRE	RPM	Avance	RPM	Avance	RPM	Avance	RPM	Avance	RPM	Avance
16.0	615	110	305	57	215	40	160	20	1 850	336
20.0	500	110	255	55	180	38	125	15	1 350	324
25.0	380	80	190	47	135	30	100	16	1 150	270
32.0	300	125	155	64	100	40	80	16	920	375
40.0	250	130	125	64	90	45	60	16	765	387
50.0	190	90	100	42	75	36	50	16	550	265
63.0	150	75	80	40	60	32	40	15	450	240

R.P.M. = tours/minute
Avance = mm/minute

HSS-E, FRAISE POUR QUEUE D'ARRONDE TYPE "B", "D", "F"

réf. C782, C783

Matière Usinée	Aciers carbone Aciers alliés		Aciers carbone Aciers alliés Aciers à outil		Aciers carbone Aciers alliés Aciers à outil		Aciers carbone Aciers alliés Aciers à outil		Aluminium Aluminium allié	
	DURETÉ	RESISTANCE	DURETÉ	RESISTANCE	DURETÉ	RESISTANCE	DURETÉ	RESISTANCE	DURETÉ	RESISTANCE
DIAMETRE	RPM	Avance	RPM	Avance	RPM	Avance	RPM	Avance	RPM	Avance
16.0	615	110	305	57	215	40	160	20	1 850	336
20.0	500	110	255	55	180	38	125	15	1 350	324
25.0	380	80	190	47	135	30	100	16	1 150	270
32.0	300	125	155	64	100	40	80	16	920	375

R.P.M. = tours/minute
Avance = mm/minute

HSS-E, FRAISE WOODRUFF TYPE "B", "D", "F"

réf. C784

Matière Usinée	Aciers carbone Aciers alliés		Aciers carbone Aciers alliés Aciers à outil		Aciers carbone Aciers alliés Aciers à outil		Aciers carbone Aciers alliés Aciers à outil		Aluminium Aluminium allié	
DURETÉ			~ HRc20		HRc20 ~ HRc30		HRc30 ~ HRc40			
RESISTANCE	~ 500N/mm ²		500 ~ 800N/mm ²		800 ~ 1000N/mm ²		1000 ~ 1300N/mm ²			
DIAMETRE	RPM	Avance	RPM	Avance	RPM	Avance	RPM	Avance	RPM	Avance
10.5	900	72	600	48	480	38	300	24	3000	240
13.5	700	56	470	38	370	30	230	18	2300	184
16.5	570	114	380	76	300	60	190	38	1900	380
19.5	480	134	320	90	260	73	160	45	1600	448
22.5	420	168	280	112	220	88	140	56	1400	560
28.5	330	165	220	110	180	90	110	55	1100	550
32.5	290	209	190	137	155	112	90	65	900	648
45.5	210	206	130	127	110	108	70	69	700	686

R.P.M. = tours/minute
Avance = mm/minute

HSS-E, FRAISE RAINURE A T, TYPE "AB", "AB", "AD"

réf. C785

Matière Usinée	Aciers carbone Aciers alliés		Aciers carbone Aciers alliés Aciers à outil		Aciers carbone Aciers alliés Aciers à outil		Aluminium	
DURETÉ			~ HRc20		HRc20 ~ HRc30			
RESISTANCE	~ 500N/mm ²		500 ~ 800N/mm ²		800 ~ 1000N/mm ²			
DIAMETRE	RPM	Avance	RPM	Avance	RPM	Avance	RPM	Avance
12.5	770	38	380	16	270	8	2 350	110
16.0	600	45	300	19	210	9	1 830	140
18.0	550	47	270	20	195	12	1 680	150
19.0	500	50	250	20	180	15	1 540	160
21.0	470	52	230	22	160	16	1 430	165
22.0	440	55	220	25	150	17	1 330	170
25.0	390	65	190	30	135	18	1 170	180
28.0	345	75	170	38	120	20	1 040	210
32.0	310	90	150	42	100	20	910	250
50.0	270	80	135	40	90	20	800	230
63.0	240	70	120	38	85	20	730	210

R.P.M. = tours/minute
Avance = mm/minute

HSS-E, FRAISE 3 TAILLES, DENTURE DROITE

réf. C786

Matière Usinée	Aciers carbone Aciers alliés		Aciers carbone Aciers alliés Aciers à outil		Aciers carbone Aciers alliés Aciers à outil		Aciers carbone Aciers alliés Aciers à outil		Aluminium Aluminium allié	
DURETÉ			~ HRc20		HRc20 ~ HRc30		HRc30 ~ HRc40			
RESISTANCE	~ 500N/mm ²		500 ~ 800N/mm ²		800 ~ 1000N/mm ²		1000 ~ 1300N/mm ²			
DIAMETRE	RPM	Avance	RPM	Avance	RPM	Avance	RPM	Avance	RPM	Avance
50.0	160	130	115	82	95	58	76	42	630	200
63.0	125	160	90	72	75	51	60	38	500	250
80.0	100	145	70	69	60	48	47	34	400	250
100.0	80	130	60	60	47	41	38	30	320	200
125.0	63	100	45	54	38	38	30	26	250	200

R.P.M. = tours/minute
Avance = mm/minute

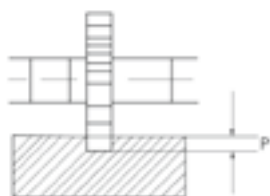

► Profondeur de fraisage P = largeur de faces

HSS-E, FRAISE 3 TAILLES, DENTURE ALTERNÉE

réf. C787

Matière Usinée	Aciers carbone Aciers alliés		Aciers carbone Aciers alliés Aciers à outil		Aciers carbone Aciers alliés Aciers à outil		Aciers carbone Aciers alliés Aciers à outil		Aluminium Aluminium allié	
DURETÉ			~ HRc20		HRc20 ~ HRc30		HRc30 ~ HRc40			
RESISTANCE	~ 500N/mm ²		500 ~ 800N/mm ²		800 ~ 1000N/mm ²		1000 ~ 1300N/mm ²			
DIAMETRE	RPM	Avance	RPM	Avance	RPM	Avance	RPM	Avance	RPM	Avance
50.0	160	130	115	85	95	58	76	42	630	200
63.0	125	160	90	75	75	51	60	38	500	250
80.0	100	145	70	69	60	48	47	34	400	250
100.0	80	130	60	60	47	41	38	30	320	200
125.0	63	100	45	54	38	38	30	26	250	200
160.0	50	105	37	48	30	34	23	24	200	150
200.0	40	95	31	45	25	31	19	22	160	150

R.P.M. = tours/minute
Avance = mm/minute

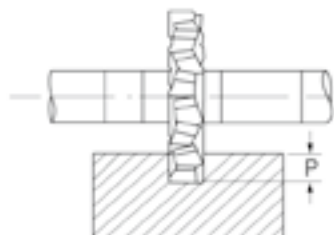

► Profondeur de fraisage P = largeur de faces

HSSCo8, FRAISE TROU LISSE FINITION MULTI DENTS

réf. C788

Matière Usinée	Aciers carbone Aciers alliés Aciers à outil		Aciers carbone Aciers alliés Aciers à outil		Aciers carbone Aciers alliés Aciers à outil		Aciers carbone Aciers alliés Aciers à outil	
DURETÉ	~ HRc20		HRc20 ~ HRc28		HRc25 ~ HRc35		HRc35 ~ HRc40	
RESISTANCE	~ 800N/mm ²		800 ~ 900N/mm ²		900 ~ 1100N/mm ²		1100 ~ 1300N/mm ²	
DIAMETRE	RPM	Avance	RPM	Avance	RPM	Avance	RPM	Avance
40.0	240	135	200	120	140	80	80	50
50.0	200	125	170	105	120	75	70	45
63.0	150	110	130	95	90	65	50	40
80.0	120	120	100	100	80	75	40	40
100.0	100	115	80	95	60	70	30	35
125.0	80	115	70	95	50	65	20	35
160.0	60	110	60	100	40	65	20	35



R.P.M. = tours/minute
Avance = mm/minute

HSSCo8, FRAISE TROU LISSE FINITION POUR ALUMINIUM

réf. C789

Matière Usinée	Aluminium Métaux non-ferreux	
DIAMETRE	RPM	Avance
30.0	1050	210
40.0	840	200
50.0	600	250
60.0	500	300
63.0	480	330
75.0	450	350
80.0	390	300
100.0	320	290



R.P.M. = tours/minute
Avance = mm/minute

HSSCo8, FRAISE TROU LISSE EBAUCHE MULTI DENTS

réf. C790, C791

Matière Usinée	Aciers carbone Aciers alliés Aciers à outil		Aciers carbone Aciers alliés Aciers à outil		Aciers carbone Aciers alliés Aciers à outil		Aciers carbone Aciers alliés Aciers à outil	
DURETÉ	~ HRc20		HRc20 ~ HRc28		HRc25 ~ HRc35		HRc35 ~ HRc40	
RESISTANCE	~ 800N/mm ²		800 ~ 900N/mm ²		900 ~ 1100N/mm ²		1100 ~ 1300N/mm ²	
DIAMETRE	RPM	Avance	RPM	Avance	RPM	Avance	RPM	Avance
40.0	240	100	200	85	140	60	80	35
50.0	200	125	170	105	120	75	70	45
63.0	150	110	130	95	90	65	50	40
80.0	120	120	100	100	80	75	40	40
100.0	100	115	80	95	60	70	30	35
125.0	80	115	70	95	50	65	20	35
160.0	60	110	60	100	40	65	20	35



R.P.M. = tours/minute
Avance = mm/minute

HSSCo8, FRAISE TROU LISSE EBAUCHE & FINITION MULTI DENTS

réf. C792

Matière Usinée	Aciers carbone Aciers alliés Aciers à outil		Aciers carbone Aciers alliés Aciers à outil		Aciers carbone Aciers alliés Aciers à outil		Aciers carbone Aciers alliés Aciers à outil	
DURETÉ	~ HRc20		HRc20 ~ HRc28		HRc25 ~ HRc35		HRc35 ~ HRc40	
RESISTANCE	~ 800N/mm ²		800 ~ 900N/mm ²		900 ~ 1100N/mm ²		1100 ~ 1300N/mm ²	
DIAMETRE	RPM	Avance	RPM	Avance	RPM	Avance	RPM	Avance
40.0	240	100	200	85	140	60	80	35
50.0	200	125	170	105	120	75	70	45
63.0	150	110	130	95	90	65	50	40
80.0	120	120	100	100	80	75	40	40
100.0	100	115	80	95	60	70	30	35
125.0	80	115	70	95	50	65	20	35
160.0	60	110	60	100	40	65	20	35

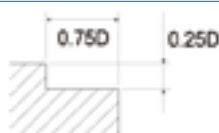

R.P.M. = tours/minute
Avance = mm/minute

HSSCo8, FRAISE 4 DENTS A RAYONNER 1/4 DE CERCLE

réf. C793

Matière Usinée		Aluminium Aluminium allié		Aciers carbone Aciers alliés		Aciers carbone Aciers alliés Aciers à outil		Aciers carbone Aciers alliés Aciers à outil	
DURETÉ						~ HRc20		HRc20 ~ HRc35	
RESISTANCE				~ 500N/mm ²		500 ~ 800N/mm ²		800 ~ 1100N/mm ²	
DIAMETRE EXTERNE	RAYON	RPM	Avance	RPM	Avance	RPM	Avance	RPM	Avance
8.0	R1	3500	245	800	55	600	35	480	35
9.0	R1.5	2800	230	630	55	470	30	380	35
10.0	R2	2800	220	630	50	470	30	380	30
11.0	R2.5	2400	220	530	45	390	30	315	30
12.0	R3	2400	210	530	45	390	30	315	30
14.0	R4	2000	200	450	45	330	30	270	25
16.0	R5	1600	200	350	40	260	30	210	25
20.0	R6	1400	190	310	40	230	30	185	25
24.0	R8	1200	180	260	40	190	30	155	25
28.0	R10	950	170	210	35	155	25	125	25
34.0	R12	800	160	180	35	130	25	105	20
48.0	R16	600	140	130	30	95	20	75	15

R.P.M. = tours/minute
Avance = mm/minute

HSS, FRAISE A ÉBAVURER 3 DENTS

réf. Z156



Matière Usinée	V	S		
		Ø≤10	Ø≤20	Ø≤30
Aciers ≤ 500N/mm ²	17-22	0.30	0.32	0.36
Aciers 500~800N/mm ²	10-15	0.28	0.30	0.31
Aciers 800~1000N/mm ²	8-12	0.24	0.26	0.28
Aciers - Aciers INOX 1000~1300N/mm ²	6-8	0.20	0.20	0.22
Aciers INOX	4-6	0.08	0.09	0.10
Fontes	15-25	0.13	0.19	0.24
Aluminium	35-45	0.27	0.30	0.35
Laiton-Bronze	20-30	0.30	0.30	0.31
Cuivre	10-15	0.29	0.30	0.31
Plastiques	35-70	0.40	0.45	0.50

V = Vitesse de coupe (mm/min)
S = Avance par tour (mm/tour)



corai
Outils coupants

FORETS







FRAISES

TARAUDS



corai

ALÉSOIRS

Z102	ALESOIR HSS à main droit, coupe à droite, queue nominale, chanfrein d'entrée conique		p. 160
Z103	ALESOIR HSS à main, hélice à gauche coupe à droite, queue nominale, chanfrein d'entrée conique		p. 161
Z104	ALESOIR machine HSS-E droit, queue cylindrique, coupe à droite		p. 162
Z105	ALESOIR machine HSS-E queue cylindrique, hélice à gauche coupe à droite		p. 163
Z106	ALESOIR machine HSS-E queue cylindrique, hélice rapide à gauche coupe à droite, chanfrein d'entrée conique		p. 164
Z107	ALESOIR machine HSS-E droit, queue cône morse		p. 165
Z108	ALESOIR machine HSS-E, queue cône morse, hélice à gauche, coupe à droite		p. 166

DONNÉES TECHNIQUES

Conditions de coupe recommandées

page 167

ALESOIR HSS À MAIN DROIT, COUPE À DROITE, QUEUE NOMINALE, CHANFREIN D'ENTRÉE CONIQUE

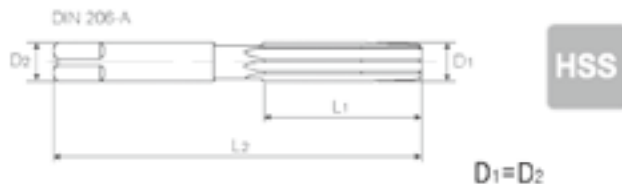

réf. Z102

Ø nominal	Dimensions	Nombre de dents	Réf.	Prix unitaire TARIF H.T.	Ø nominal	Dimensions	Nombre de dents	Réf.	Prix unitaire TARIF H.T.
	DxL1xL2					DxL1xL2			
2.0	2x25x50	4	Z102 0200	17.72 €	25.0	25x115x231	8	Z102 2500	111.94 €
2.2	2,2x27x54	4	Z102 0220	17.72 €	26.0	26x115x231	8	Z102 2600	116.59 €
2.5	2,5x29x58	4	Z102 0250	17.72 €	27.0	27x124x247	10	Z102 2700	153.46 €
2.8	2,8x31x62	4	Z102 0280	19.12 €	28.0	28x124x247	10	Z102 2800	153.79 €
3.0	3x31x62	6	Z102 0300	19.12 €	29.0	29x124x247	10	Z102 2900	161.19 €
3.2	3,2x33x66	6	Z102 0320	19.12 €	30.0	30x124x247	10	Z102 3000	161.56 €
3.5	3,5x35x71	6	Z102 0350	19.12 €	31.0	31x133x265	10	Z102 3100	178.45 €
4.0	4x38x76	6	Z102 0400	18.79 €	32.0	32x133x265	10	Z102 3200	178.82 €
4.5	4,5x41x81	6	Z102 0450	18.79 €	33.0	33x133x265	10	Z102 3300	181.75 €
5.0	5x44x87	6	Z102 0500	18.34 €	34.0	34x142x284	10	Z102 3400	182.70 €
5.5	5,5x47x93	6	Z102 0550	19.93 €	35.0	35x142x284	10	Z102 3500	217.43 €
6.0	6x47x93	6	Z102 0600	20.50 €	36.0	36x142x284	10	Z102 3600	217.88 €
7.0	7x54x107	6	Z102 0700	21.67 €	37.0	37x142x284	10	Z102 3700	219.53 €
8.0	8x58x115	6	Z102 0800	22.36 €	38.0	38x152x305	10	Z102 3800	227.43 €
9.0	9x62x124	6	Z102 0900	29.42 €	38.1	38,1x152x305	10	Z102 3810	230.61 €
10.0	10x66x133	6	Z102 1000	29.52 €	39.0	39x152x305	10	Z102 3900	238.70 €
11.0	11x71x142	6	Z102 1100	29.69 €	40.0	40x152x305	10	Z102 4000	243.87 €
12.0	12x76x152	6	Z102 1200	32.87 €	41.0	41x152x305	12	Z102 4100	259.55 €
13.0	13x76x152	6	Z102 1300	48.60 €	42.0	42x152x305	12	Z102 4200	270.93 €
14.0	14x81x163	8	Z102 1400	55.11 €	43.0	43x163x326	12	Z102 4300	282.47 €
15.0	15x81x163	8	Z102 1500	61.03 €	44.0	44x163x326	12	Z102 4400	297.62 €
16.0	16x87x175	8	Z102 1600	63.00 €	45.0	45x163x326	12	Z102 4500	315.53 €
17.0	17x87x175	8	Z102 1700	66.62 €	46.0	46x163x326	12	Z102 4600	326.55 €
18.0	18x93x188	8	Z102 1800	74.85 €	47.0	47x163x326	12	Z102 4700	346.81 €
19.0	19x93x188	8	Z102 1900	74.99 €	48.0	48x174x347	12	Z102 4800	363.82 €
20.0	20x100x201	8	Z102 2000	81.17 €	49.0	49x174x347	12	Z102 4900	375.29 €
22.0	22x107x215	8	Z102 2200	89.34 €	52.0	52x174x347	12	Z102 5200	436.25 €
24.0	24x115x231	8	Z102 2400	108.57 €	60.0	60x184x367	12	Z102 6000	614.00 €

ALESOIR HSS À MAIN, HÉLICE À GAUCHE COUPE À DROITE, QUEUE NOMINALE, CHANFREIN D'ENTRÉE CONIQUE

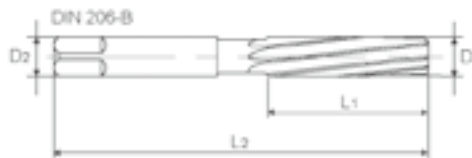
 $D_1 = D_2$

réf. Z103

Ø nominal	Dimensions	Nombre de dents	Réf.	Prix unitaire TARIF H.T.	Ø nominal	Dimensions	Nombre de dents	Réf.	Prix unitaire TARIF H.T.
	DxL1xL2					DxL1xL2			
2.0	2x25x50	4	Z103 0200	19.69 €	25.0	25x115x231	8	Z103 2500	120.65 €
2.2	2,2x27x54	4	Z103 0220	19.69 €	26.0	26x115x231	8	Z103 2600	125.49 €
2.5	2,5x29x58	4	Z103 0250	19.69 €	27.0	27x124x247	10	Z103 2700	165.89 €
2.8	2,8x31x62	4	Z103 0280	21.21 €	28.0	28x124x247	10	Z103 2800	165.89 €
3.0	3x31x62	6	Z103 0300	21.21 €	29.0	29x124x247	10	Z103 2900	173.79 €
3.2	3,2x33x66	6	Z103 0320	21.21 €	30.0	30x124x247	10	Z103 3000	173.79 €
3.5	3,5x35x71	6	Z103 0350	21.21 €	31.0	31x133x265	10	Z103 3100	191.71 €
4.0	4x38x76	6	Z103 0400	20.83 €	32.0	32x133x265	10	Z103 3200	191.71 €
4.5	4,5x41x81	6	Z103 0450	20.83 €	33.0	33x133x265	10	Z103 3300	194.58 €
5.0	5x44x87	6	Z103 0500	20.38 €	34.0	34x142x284	10	Z103 3400	194.58 €
5.5	5,5x47x93	6	Z103 0550	22.12 €	35.0	35x142x284	10	Z103 3500	232.66 €
6.0	6x47x93	6	Z103 0600	22.68 €	36.0	36x142x284	10	Z103 3600	232.66 €
7.0	7x54x107	6	Z103 0700	23.96 €	37.0	37x142x284	10	Z103 3700	233.93 €
8.0	8x58x115	6	Z103 0800	24.72 €	38.0	38x152x305	10	Z103 3800	241.39 €
9.0	9x62x124	6	Z103 0900	32.49 €	38.1	38,1x152x305	10	Z103 3810	244.94 €
10.0	10x66x133	6	Z103 1000	32.49 €	39.0	39x152x305	10	Z103 3900	253.29 €
11.0	11x71x142	6	Z103 1100	32.68 €	40.0	40x152x305	10	Z103 4000	258.43 €
12.0	12x76x152	6	Z103 1200	36.12 €	41.0	41x152x305	12	Z103 4100	275.20 €
13.0	13x76x152	6	Z103 1300	53.58 €	42.0	42x152x305	12	Z103 4200	287.30 €
14.0	14x81x163	8	Z103 1400	60.73 €	43.0	43x163x326	12	Z103 4300	298.39 €
15.0	15x81x163	8	Z103 1500	67.15 €	44.0	44x163x326	12	Z103 4400	314.57 €
16.0	16x87x175	8	Z103 1600	69.14 €	45.0	45x163x326	12	Z103 4500	333.68 €
17.0	17x87x175	8	Z103 1700	73.20 €	46.0	46x163x326	12	Z103 4600	345.22 €
18.0	18x93x188	8	Z103 1800	82.13 €	47.0	47x163x326	12	Z103 4700	366.94 €
19.0	19x93x188	8	Z103 1900	82.13 €	48.0	48x174x347	12	Z103 4800	383.82 €
20.0	20x100x201	8	Z103 2000	88.73 €	49.0	49x174x347	12	Z103 4900	395.67 €
22.0	22x107x215	8	Z103 2200	97.35 €	52.0	52x174x347	12	Z103 5200	460.85 €
24.0	24x115x231	8	Z103 2400	118.30 €	60.0	60x184x367	12	Z103 6000	648.97 €

ALESOIR MACHINE HSS-E DROIT, QUEUE CYLINDRIQUE, COUPE À DROITE

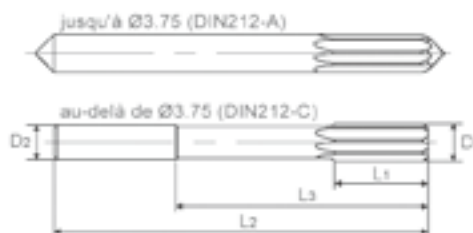

HSS-E

réf. Z104

conditions de coupe recommandées p. 167

Ø nominal	Dimensions	Nombre de dents	Réf.	Prix unitaire TARIF H.T.
	D1xD2xL1xL3xL2			
2.0	2x2x11x-x49	4	Z104 0200	22.86 €
2.2	2.2x2.2x12x-x53	4	Z104 0220	19.44 €
2.5	2.5x2.5x14x-x57	4	Z104 0250	19.44 €
2.6	2.6x2.6x14x-x57	4	Z104 0260	19.44 €
2.8	2.8x2.8x15x-x61	4	Z104 0280	19.44 €
3.0	3x3x15x-x61	6	Z104 0300	19.44 €
3.1	3.1x3.1x16x-x65	6	Z104 0310	19.44 €
3.2	3.2x3.2x16x-x65	6	Z104 0320	19.44 €
3.5	3.5x3.5x18x-x70	6	Z104 0350	19.44 €
3.6	3.6x3.6x18x-x70	6	Z104 0360	20.77 €
3.7	3.7x3.7x18x-x70	6	Z104 0370	20.77 €
4.0	4x4x19x42x75	6	Z104 0400	20.77 €
4.3	4.3x4.5x21x46x80	6	Z104 0430	21.73 €
4.5	4.5x4.5x21x46x80	6	Z104 0450	21.73 €
4.6	4.6x4.5x21x46x80	6	Z104 0460	22.17 €
5.0	5x5x23x51x86	6	Z104 0500	22.17 €
5.5	5.5x5.6x26x56x93	6	Z104 0550	22.56 €
5.6	5.6x5.6x26x56x93	6	Z104 0560	22.93 €
6.0	6x5.6x26x56x93	6	Z104 0600	22.93 €
6.5	6.5x6.3x28x62x101	6	Z104 0650	22.93 €
7.0	7x7.1x31x68x109	6	Z104 0700	28.86 €
7.2	7.2x7.1x31x68x109	6	Z104 0720	29.52 €
8.0	8x8x33x74x117	6	Z104 0800	29.52 €
8.3	8.3x8x33x74x117	6	Z104 0830	37.77 €
8.5	8.5x8x33x74x117	6	Z104 0850	37.77 €
9.0	9x9x36x80x125	6	Z104 0900	37.77 €
9.5	9.5x9x36x80x125	6	Z104 0950	37.77 €
10.0	10x10x38x86x133	6	Z104 1000	37.77 €
10.5	10.5x10x38x86x133	6	Z104 1050	47.02 €
11.0	11x10x41x95x142	6	Z104 1100	47.02 €
12.0	12x10x44x104x151	6	Z104 1200	49.06 €
13.0	13x10x44x104x151	6	Z104 1300	58.15 €
14.0	14x12.5x47x108x160	8	Z104 1400	60.58 €
15.0	15x12.5x50x110x162	8	Z104 1500	65.55 €
16.0	16x12.5x52x118x170	8	Z104 1600	68.10 €
17.0	17x14x54x121x175	8	Z104 1700	82.69 €
18.0	18x14x56x128x182	8	Z104 1800	85.25 €
19.0	19x16x58x129x189	8	Z104 1900	92.87 €
20.0	20x16x60x135x195	8	Z104 2000	94.42 €

ALESOIR MACHINE HSS-E QUEUE CYLINDRIQUE, HÉLICE À GAUCHE COUPE À DROITE

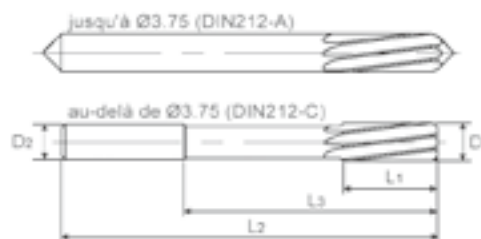

HSS-E

LH7°

réf. Z105

conditions de coupe recommandées p. 167

Ø nominal	Dimensions	Nombre de dents	Réf.	Prix unitaire TARIF H.T.
	D1xD2xL1xL3xL2			
2.0	2x2x11x-x49	4	Z105 0200	25.43 €
2.2	2.2x2.2x12x-x53	4	Z105 0220	21.59 €
2.5	2.5x2.5x14x-x57	4	Z105 0250	21.59 €
2.6	2.6x2.6x14x-x57	4	Z105 0260	21.59 €
2.8	2.8x2.8x15x-x61	4	Z105 0280	21.59 €
3.0	3x3x15x-x61	6	Z105 0300	21.59 €
3.1	3.1x3.1x16x-x65	6	Z105 0310	21.59 €
3.2	3.2x3.2x16x-x65	6	Z105 0320	21.59 €
3.5	3.5x3.5x18x-x70	6	Z105 0350	21.59 €
3.6	3.6x3.6x18x-x70	6	Z105 0360	23.07 €
3.7	3.7x3.7x18x-x70	6	Z105 0370	23.07 €
4.0	4x4x19x42x75	6	Z105 0400	23.07 €
4.3	4.3x4.5x21x46x80	6	Z105 0430	24.02 €
4.5	4.5x4.5x21x46x80	6	Z105 0450	24.02 €
4.6	4.6x4.5x21x46x80	6	Z105 0460	24.52 €
5.0	5x5x23x51x86	6	Z105 0500	24.52 €
5.5	5.5x5.6x26x56x93	6	Z105 0550	25.03 €
5.6	5.6x5.6x26x56x93	6	Z105 0560	25.28 €
6.0	6x5.6x26x56x93	6	Z105 0600	25.28 €
6.5	6.5x6.3x28x62x101	6	Z105 0650	25.28 €
7.0	7x7.1x31x68x109	6	Z105 0700	31.92 €
7.2	7.2x7.1x31x68x109	6	Z105 0720	32.62 €
8.0	8x8x33x74x117	6	Z105 0800	32.62 €
8.3	8.3x8x33x74x117	6	Z105 0830	41.74 €
8.5	8.5x8x33x74x117	6	Z105 0850	41.74 €
9.0	9x9x36x80x125	6	Z105 0900	41.74 €
9.5	9.5x9x36x80x125	6	Z105 0950	41.74 €
10.0	10x10x38x86x133	6	Z105 1000	41.74 €
10.5	10.5x10x38x86x133	6	Z105 1050	51.71 €
11.0	11x10x41x95x142	6	Z105 1100	51.71 €
12.0	12x10x44x104x151	6	Z105 1200	53.97 €
13.0	13x10x44x104x151	6	Z105 1300	63.92 €
14.0	14x12.5x47x108x160	8	Z105 1400	66.52 €
15.0	15x12.5x50x110x162	8	Z105 1500	71.85 €
16.0	16x12.5x52x118x170	8	Z105 1600	74.53 €
17.0	17x14x54x121x175	8	Z105 1700	90.52 €
18.0	18x14x56x128x182	8	Z105 1800	93.22 €
19.0	19x16x58x129x189	8	Z105 1900	101.36 €
20.0	20x16x60x135x195	8	Z105 2000	102.83 €

ALESOIR MACHINE HSS-E QUEUE CYLINDRIQUE, HÉLICE RAPIDE À GAUCHE COUPE À DROITE, CHANFREIN D'ENTRÉE CONIQUE

HSS-E

LH45°

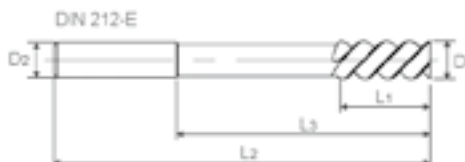

réf. Z106

conditions de coupe recommandées p. 167

Ø nominal	Dimensions	Nombre de dents	Réf.	Prix unitaire TARIF H.T.
	D1xD2xL1xL3xL2			
4.0	4x4x19x42x75	3	Z106 0400	25.37 €
4.5	4,5x4,5x21x46x80	3	Z106 0450	26.37 €
5.0	5x5x23x51x86	3	Z106 0500	26.88 €
5.5	5,5x5,6x26x56x93	3	Z106 0550	27.46 €
6.0	6x5,6x26x56x93	3	Z106 0600	27.72 €
6.5	6,5x6,3x28x62x101	3	Z106 0650	27.72 €
7.0	7x7,1x31x68x109	3	Z106 0700	34.91 €
8.0	8x8x33x74x117	3	Z106 0800	35.66 €
8.5	8,5x8x33x74x117	3	Z106 0850	45.63 €
9.0	9x9x36x80x125	3	Z106 0900	45.63 €
9.5	9,5x9x36x80x125	3	Z106 0950	45.63 €
10.0	10x10x38x86x133	3	Z106 1000	45.63 €
11.0	11x10x41x95x142	3	Z106 1100	56.51 €
12.0	12x10x44x104x151	3	Z106 1200	58.82 €
13.0	13x10x44x104x151	3	Z106 1300	69.70 €
14.0	14x12,5x47x108x160	4	Z106 1400	72.37 €
15.0	15x12,5x50x110x162	4	Z106 1500	78.16 €
16.0	16x12,5x52x118x170	4	Z106 1600	81.02 €
17.0	17x14x54x121x175	4	Z106 1700	98.36 €
18.0	18x14x56x128x182	4	Z106 1800	101.16 €
19.0	19x16x58x129x189	4	Z106 1900	109.97 €
20.0	20x16x60x135x195	4	Z106 2000	111.36 €

ALESOIR MACHINE HSS-E DROIT, QUEUE CÔNE MORSE, CHANFREIN D'ENTRÉE À 45°

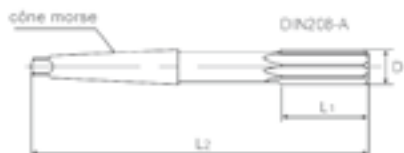

HSS-E

réf. Z107

conditions de coupe recommandées p. 167

Ø nominal	Dimensions	Nombre de dents	Réf.	Prix unitaire TARIF H.T.
	D1xL1xL2			
10.0	10xMT1x38x168	6	Z107 1000	52.12 €
11.0	11xMT1x41x175	6	Z107 1100	56.23 €
12.0	12xMT1x44x182	6	Z107 1200	56.23 €
13.0	13xMT1x44x182	6	Z107 1300	58.99 €
14.0	14xMT1x47x189	8	Z107 1400	58.99 €
15.0	15xMT2x50x204	8	Z107 1500	72.68 €
16.0	16xMT2x52x210	8	Z107 1600	74.01 €
17.0	17xMT2x54x214	8	Z107 1700	78.16 €
18.0	18xMT2x56x219	8	Z107 1800	78.16 €
19.0	19xMT2x58x223	8	Z107 1900	86.46 €
20.0	20xMT2x60x228	8	Z107 2000	86.46 €
21.0	21xMT2x62x232	8	Z107 2100	97.27 €
22.0	22xMT2x64x237	8	Z107 2200	97.27 €
23.0	23xMT2x66x241	8	Z107 2300	115.12 €
24.0	24xMT3x68x268	8	Z107 2400	117.85 €
25.0	25xMT3x68x268	8	Z107 2500	117.85 €
26.0	26xMT3x70x273	8	Z107 2600	146.71 €
27.0	27xMT3x71x277	10	Z107 2700	163.09 €
28.0	28xMT3x71x277	10	Z107 2800	163.09 €
29.0	29xMT3x73x281	10	Z107 2900	182.39 €
30.0	30xMT3x73x281	10	Z107 3000	182.39 €
31.0	31xMT3x75x285	10	Z107 3100	182.95 €
32.0	32xMT4x77x317	10	Z107 3200	215.19 €
34.0	34xMT4x78x321	10	Z107 3400	228.31 €
35.0	35xMT4x78x321	10	Z107 3500	228.31 €
36.0	36xMT4x79x325	10	Z107 3600	286.18 €
38.0	38xMT4x81x329	10	Z107 3800	317.38 €
40.0	40xMT4x81x329	10	Z107 4000	317.38 €
41.0	41xMT4x82x333	12	Z107 4100	446.32 €
42.0	42xMT4x82x333	12	Z107 4200	446.32 €
43.0	43xMT4x83x336	12	Z107 4300	462.76 €
44.0	44xMT4x83x336	12	Z107 4400	462.76 €
45.0	45xMT4x83x336	12	Z107 4500	462.76 €
46.0	46xMT4x84x340	12	Z107 4600	578.32 €
47.0	47xMT4x84x340	12	Z107 4700	578.32 €
48.0	48xMT4x86x344	12	Z107 4800	578.32 €
50.0	50xMT4x86x344	12	Z107 5000	578.32 €

ALESOIR MACHINE HSS-E, QUEUE CÔNE MORSE, HÉLICE À GAUCHE, COUPE À DROITE CHANFREIN D'ENTRÉE À 45°

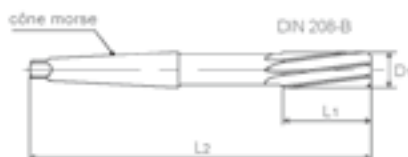

réf. Z108

conditions de coupe recommandées p. 167

Ø nominal	Dimensions	Nombre de dents	Réf.	Prix unitaire TARIF H.T.
	D1xL1xL2			
10.0	10xMT1x38x168	6	Z108 1000	47.89 €
11.0	11xMT1x41x175	6	Z108 1100	56.51 €
12.0	12xMT1x44x182	6	Z108 1200	56.51 €
13.0	13xMT1x44x182	6	Z108 1300	56.51 €
14.0	14xMT1x47x189	8	Z108 1400	56.51 €
15.0	15xMT2x50x204	8	Z108 1500	64.78 €
16.0	16xMT2x52x210	8	Z108 1600	68.10 €
17.0	17xMT2x54x214	8	Z108 1700	79.57 €
18.0	18xMT2x56x219	8	Z108 1800	79.57 €
19.0	19xMT2x58x223	8	Z108 1900	86.46 €
20.0	20xMT2x60x228	8	Z108 2000	86.46 €
21.0	21xMT2x62x232	8	Z108 2100	96.58 €
22.0	22xMT2x64x237	8	Z108 2200	96.58 €
23.0	23xMT2x66x241	8	Z108 2300	112.38 €
24.0	24xMT3x68x268	8	Z108 2400	117.85 €
25.0	25xMT3x68x268	8	Z108 2500	117.85 €
26.0	26xMT3x70x273	8	Z108 2600	146.71 €
27.0	27xMT3x71x277	10	Z108 2700	163.09 €
28.0	28xMT3x71x277	10	Z108 2800	163.09 €
29.0	29xMT3x73x281	10	Z108 2900	168.58 €
30.0	30xMT3x73x281	10	Z108 3000	168.58 €
31.0	31xMT3x75x285	10	Z108 3100	169.15 €
32.0	32xMT4x77x317	10	Z108 3200	198.89 €
34.0	34xMT4x78x321	10	Z108 3400	210.99 €
35.0	35xMT4x78x321	10	Z108 3500	210.99 €
36.0	36xMT4x79x325	10	Z108 3600	264.51 €
38.0	38xMT4x81x329	10	Z108 3800	293.38 €
40.0	40xMT4x81x329	10	Z108 4000	293.38 €
41.0	41xMT4x82x333	12	Z108 4100	412.56 €
42.0	42xMT4x82x333	12	Z108 4200	412.56 €
43.0	43xMT4x83x336	12	Z108 4300	427.79 €
44.0	44xMT4x83x336	12	Z108 4400	427.79 €
45.0	45xMT4x83x336	12	Z108 4500	427.79 €
46.0	46xMT4x84x340	12	Z108 4600	534.63 €
47.0	47xMT4x84x340	12	Z108 4700	534.63 €
48.0	48xMT4x86x344	12	Z108 4800	534.63 €
50.0	50xMT4x86x344	12	Z108 5000	534.63 €

HSS-E, ALÉSOIRS MACHINE DROIT - HÉLICE À GAUCHE

ref. Z104, Z105

Matière Usinée	Vitesse de coupe	Avance (mm/tour)					
	m/min.	Ø2 ~ Ø4	Ø4 ~ Ø8	Ø8 ~ Ø13	Ø13 ~ Ø20	Ø20 ~ Ø30	> Ø30
Aciers < 500N/mm ²	12 ~ 16	0.05~0.15	0.10~0.20	0.15~0.25	0.20~0.30	0.25~0.40	0.35~0.50
Aciers 500-700N/mm ²	10 ~ 12	0.05~0.15	0.10~0.20	0.15~0.25	0.20~0.30	0.25~0.40	0.35~0.50
Aciers 700-800N/mm ²	6 ~ 8	0.05~0.10	0.08~0.16	0.10~0.20	0.15~0.25	0.20~0.30	0.30~0.40
Aciers alliés ou Fontes d'acier < 500N/mm ²	6 ~ 10	0.05~0.10	0.08~0.16	0.10~0.20	0.15~0.25	0.20~0.30	0.30~0.40
Aciers alliés ou Fontes d'acier > 500N/mm ²	4 ~ 6	0.05~0.10	0.08~0.16	0.10~0.20	0.15~0.25	0.20~0.30	0.30~0.40
Aciers alliés ou Aciers forgés	4 ~ 6	0.03~0.08	0.06~0.10	0.08~0.15	0.10~0.20	0.15~0.25	0.20~0.30
Fontes < 200HB	12 ~ 14	0.05~0.15	0.10~0.20	0.15~0.25	0.20~0.30	0.25~0.40	0.35~0.50
Fontes > 200HB	10 ~ 12	0.05~0.10	0.08~0.16	0.10~0.20	0.15~0.25	0.20~0.30	0.30~0.40
Aluminium ou Aluminium alliés	16 ~ 20	0.10~0.20	0.15~0.25	0.20~0.30	0.25~0.40	0.35~0.50	0.40~0.60
Magnesium ou Magnesium alliés	10 ~ 16	0.10~0.20	0.15~0.25	0.20~0.30	0.25~0.40	0.35~0.50	0.40~0.60
Cuivre, Laiton	16 ~ 18	0.10~0.20	0.15~0.25	0.20~0.30	0.25~0.40	0.35~0.50	0.40~0.60
INOX	4 ~ 6	0.03~0.08	0.06~0.10	0.08~0.15	0.10~0.20	0.15~0.25	0.20~0.30
Plastiques	8 ~ 12	0.10~0.20	0.20~0.30	0.30~0.40	0.40~0.50	0.50~0.60	0.60~0.80

HSS-E, ALÉSOIRS MACHINE HSS-E QUEUE CYLINDRIQUE - HÉLICE RAPIDE COUPE À DROITE

ref. Z106

Matière Usinée	Vitesse de coupe	Avance (mm/tour)			
	m/min.	Ø2 ~ Ø4	Ø4 ~ Ø8	Ø8 ~ Ø13	Ø13 ~ Ø20
Aciers < 500N/mm ²	16 ~ 18	0.08~0.16	0.16~0.25	0.20~0.30	0.30~0.40
Aciers 500-700N/mm ²	14 ~ 16	0.08~0.16	0.16~0.25	0.20~0.30	0.30~0.40
Aluminium ou Aluminium alliés	18 ~ 22	0.10~0.20	0.20~0.30	0.30~0.40	0.40~0.60
Magnesium ou Magnesium alliés	10 ~ 16	0.08~0.16	0.16~0.25	0.20~0.30	0.30~0.40
Cuivre, Laiton	16 ~ 20	0.08~0.16	0.16~0.25	0.20~0.30	0.30~0.40
Plastiques	12 ~ 14	0.10~0.20	0.20~0.30	0.30~0.40	0.40~0.60



corai
Outils coupants

FORETS

FRAISES

TARAUDS



corai

FRAISE À LAMER 3 DENTS POUR VIS À FOND PLAT



HSS-E

DIN
373

réf. Z120

conditions de coupe recommandées p. 170

MEDIUM

Ø de vis	Ø du Pilote	Ø de Lamage	Ø de queue	Longueur Totale	Réf.	Prix unitaire TARIF H.T.
	D(e8)	D1(z9)	D2(h9)	L		
M3	3.4	6.0	5	71	Z120 0600 034	17.45 €
M3.5	3.9	6.5	5	71	Z120 0650 140	17.45 €
M4	4.5	8.0	5	71	Z120 0800 039	13.95 €
M5	5.5	10.0	8	80	Z120 1000 045	15.11 €
M6	6.6	11.0	8	80	Z120 1100 055	16.38 €
M8	9.0	15.0	12.5	100	Z120 1500 066	26.32 €
M10	11.0	18.0	12.5	100	Z120 1800 090	31.27 €
M12	14.0	20.0	12.5	100	Z120 2000 110	33.64 €

FIN

Ø de vis	Ø du Pilote	Ø de Lamage	Ø de queue	Longueur Totale	Réf.	Prix unitaire TARIF H.T.
	D(e8)	D1(z9)	D2(h9)	L		
M3	3.2	6.0	5	71	Z120 0600 032	17.45 €
M3.5	3.7	6.5	5	71	Z120 0650 037	17.45 €
M4	4.3	8.0	5	71	Z120 0800 043	13.95 €
M5	5.3	10.0	8	80	Z120 1000 053	15.11 €
M6	6.4	11.0	8	80	Z120 1100 064	16.38 €
M8	8.4	15.0	12.5	100	Z120 1500 084	26.32 €
M10	10.5	18.0	12.5	100	Z120 1800 105	31.27 €
M12	13.0	20.0	12.5	100	Z120 2000 130	33.64 €

AVANT TARAUDAGE

Ø de vis	Ø du Pilote	Ø de Lamage	Ø de queue	Longueur Totale	Réf.	Prix unitaire TARIF H.T.
	D(e8)	D1(z9)	D2(h9)	L		
M3	2.5	6.0	5	71	Z120 0600 025	17.45 €
M3.5	2.9	6.5	5	71	Z120 0650 029	17.45 €
M4	3.3	8.0	5	71	Z120 0800 033	13.95 €
M5	4.2	10.0	8	80	Z120 1000 042	15.11 €
M6	5.0	11.0	8	80	Z120 1100 050	16.38 €
M8	6.8	15.0	12.5	100	Z120 1500 068	26.32 €
M10	8.5	18.0	12.5	100	Z120 1800 085	31.27 €
M12	10.2	20.0	12.5	100	Z120 2000 102	33.64 €

Tolérances selon DIN 7160 & 7161

Diamètre nominal en mm				
	de 1 à 3	plus de 3 à 6	plus de 6 à 10	plus de 10 à 18
Plage de tolérance en µm				
e8	- 14 - 28	- 20 - 38	- 25 - 47	- 32 - 59
h9	0 - 25	0 - 30	0 - 36	0 - 43

Diamètre nominal en mm				
	de 6 à 10	plus de 10 à 14	plus de 14 à 18	plus de 18 à 24
Plage de tolérance en µm				
z9	+ 78 + 42	+ 93 + 50	+ 103 + 60	+ 125 + 73













FRAISES À LAMER 3 DENTS

réf. Z120

Matière Usinée	Aluminium Aluminium allié	Aciers carbone Aciers alliés	Aciers carbone Aciers alliés Aciers à outil	Aciers carbone Aciers alliés Aciers à outil	Aciers carbone Aciers alliés Aciers à outil
DURETÉ			~ HRc20	HRc20 ~ HRc35	HRc35 ~ HRc40
RESISTANCE		~ 500N/mm2	500 ~ 800N/mm2	800 ~ 1100N/mm2	1100 ~ 1300N/mm2
DIAMETRE	RPM	RPM	RPM	RPM	RPM
6.0	2100	590	480	380	320
6.5	2100	590	480	380	320
8.0	1700	470	380	300	250
10.0	1200	380	320	260	170
11.0	1100	300	240	190	160
15.0	840	240	195	155	130
18.0	670	190	160	120	80
20.0	550	160	125	95	70

R.P.M. = tours/minute

FRAISES LIMES ROTATIVES CARBURE

ZRSA	Fraise lime rotative carbure cylindrique, forme A		p. 172
ZRSB	Fraise lime rotative carbure cylindrique, avec coupe en bout, forme B		p. 173
ZRSC	Fraise lime rotative carbure cylindrique, avec bout arrondi, forme C		p. 174
ZRSD	Fraise lime rotative carbure sphérique, forme D		p. 175
ZRSE	Fraise lime rotative carbure ovale, forme E		p. 176
ZRSF	Fraise lime rotative carbure ogive avec bout arrondi, forme F		p. 177
ZRSG	Fraise lime rotative carbure ogive avec bout pointu, forme G		p. 178
ZRSH	Fraise lime rotative carbure flamme, forme H		p. 178
ZRSJ	Fraise lime rotative carbure conique 60°, forme J		p. 179
ZRSK	Fraise lime rotative carbure conique 90°, forme K		p. 179
ZRSL	Fraise lime rotative carbure conique bout arrondi, forme L		p. 180
ZRSM	Fraise lime rotative carbure conique, forme M		p. 181
ZRSN	Fraise lime rotative carbure conique inversée, forme N		p. 181

DONNÉES TECHNIQUES

Informations techniques

page 182

FRAISE LIME ROTATIVE CARBURE CYLINDRIQUE, FORME A

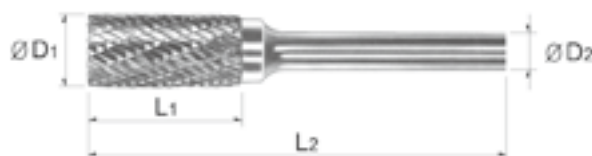

réf. ZRSA

conditions de coupe recommandées p. 182



Ø fraisage	Dimensions	COUPE DOUBLE Réf.	Prix unitaire TARIF H.T.	COUPE SIMPLE Réf.	Prix unitaire TARIF H.T.
	D1xD2xL1xL2				
1.5	1.5x3x6x38	ZRSA-41M	8.42 €	ZRSA-41MP	8.42 €
1.5	1.5x3x6x50	ZRSA-41ML2	11.66 €	ZRSA-41ML2P	11.66 €
1.5	1.5x3x6x75	ZRSA-41ML3	13.19 €	ZRSA-41ML3P	13.19 €
2.5	2.5x3x11x38	ZRSA-42M	8.42 €	ZRSA-42MP	8.42 €
2.5	2.5x3x11x50	ZRSA-42ML2	11.66 €	ZRSA-42ML2P	11.66 €
2.5	2.5x3x11x75	ZRSA-42ML3	13.19 €	ZRSA-42ML3P	13.19 €
3.0	3x3x14x38	ZRSA-43M	8.42 €	ZRSA-43MP	8.42 €
3.0	3x3x14x50	ZRSA-43ML2	11.66 €	ZRSA-43ML2P	11.66 €
3.0	3x3x14x75	ZRSA-43ML3	13.19 €	ZRSA-43ML3P	13.19 €
3.0	3x6x12x56	ZRSA-11M	15.20 €	ZRSA-11MP	15.20 €
3.0	3x6x12.7x60	ZRSA-12M	15.20 €	ZRSA-12MP	15.20 €
4.0	4x3x12.7x38	ZRSA-52M	20.20 €	ZRSA-52MP	20.20 €
4.0	4x6x16x50	ZRSA-13M	14.38 €	ZRSA-13MP	14.38 €
5.0	5x3x12.7x38	ZRSA-53M	20.20 €	ZRSA-53MP	20.20 €
5.0	5x6x16x50	ZRSA-14M	14.38 €	ZRSA-14MP	14.38 €
6.0	6x6x25x50	ZRSA-1ML	20.80 €	ZRSA-1MLP	20.80 €
6.0	6x6x16x50	ZRSA-1M	14.38 €	ZRSA-1MP	14.38 €
6.3	6.3x3x12.7x50	ZRSA-51M	13.79 €	ZRSA-51MP	13.79 €
8.0	8x6x19x63	ZRSA-2M	18.79 €	ZRSA-2MP	18.79 €
9.5	9.5x6x19x63	ZRSA-3M	20.20 €	ZRSA-3MP	20.20 €
9.5	9.5x6x25x69	ZRSA-3ML	24.04 €	ZRSA-3MLP	24.04 €
11.0	11.0x6x25x69	ZRSA-4M	29.22 €	ZRSA-4MP	29.22 €
12.7	12.7x6x25x69	ZRSA-5M	31.52 €	ZRSA-5MP	31.52 €
16.0	16x6x25x69	ZRSA-6M	43.24 €	ZRSA-6MP	43.24 €
19.0	19x6x25x69	ZRSA-7M	59.09 €	ZRSA-7MP	59.09 €
25.0	25x6x25x69	ZRSA-9M	82.64 €	ZRSA-9MP	82.64 €



Ø fraisage	Dimensions	COUPE ALUMINIUM Réf.	Prix unitaire TARIF H.T.
	D1xD2xL1xL2		
6.0	6X6X19X50	ZRSA-1MNF	15.78 €
9.5	9.5X6X19X63	ZRSA-3MNF	22.27 €
12.7	12.7X6X25X69	ZRSA-5MNF	34.71 €
16.0	16X6X25X69	ZRSA-6MNF	47.54 €
19.0	19X6X25X69	ZRSA-7MNF	65.02 €

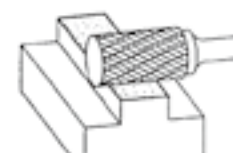

FRAISE LIME ROTATIVE CARBURE CYLINDRIQUE, AVEC COUPE EN BOUT, FORME B



réf. ZRSB

conditions de coupe recommandées p. 182



Ø fraisage	Dimensions	COUPE DOUBLE Réf.	Prix unitaire TARIF H.T.	COUPE SIMPLE Réf.	Prix unitaire TARIF H.T.
	D1xD2xL1xL2				
1.5	1.5x3x6x38	ZRSB-41M	8.42 €	ZRSB-41MP	8.42 €
1.5	1.5x3x6x50	ZRSB-41ML2	11.66 €	ZRSB-41ML2P	11.66 €
1.5	1.5x3x6x75	ZRSB-41ML3	13.19 €	ZRSB-41ML3P	13.19 €
2.5	2.5x3x11x38	ZRSB-42M	8.42 €	ZRSB-42MP	8.42 €
2.5	2.5x3x11x50	ZRSB-42ML2	11.66 €	ZRSB-42ML2P	11.66 €
2.5	2.5x3x11x75	ZRSB-42ML3	13.19 €	ZRSB-42ML3P	13.19 €
3.0	3x3x38	ZRSB-ECOM	8.42 €		
3.0	3x3x14x38	ZRSB-43M	8.89 €	ZRSB-43MP	8.89 €
3.0	3x3x14x50	ZRSB-43ML2	11.66 €	ZRSB-43ML2P	11.66 €
3.0	3x3x14x75	ZRSB-43ML3	13.19 €	ZRSB-43ML3P	13.19 €
3.0	3x6x12x56	ZRSB-11M	16.19 €	ZRSB-11MP	16.19 €
3.0	3x6x12.7x60	ZRSB-12M	16.19 €	ZRSB-12MP	16.19 €
4.0	4x6x16x50	ZRSB-13M	16.19 €	ZRSB-13MP	16.19 €
5.0	5x6x16x50	ZRSB-14M	16.19 €	ZRSB-14MP	16.19 €
6.0	6x6x16x50	ZRSB-1M	16.19 €	ZRSB-1MP	16.19 €
6.0	6x6x25x50	ZRSB-1ML	23.04 €	ZRSB-1MLP	23.04 €
6.3	6.3x3x4.7x43	ZRSB-51M	13.79 €	ZRSB-51MP	13.79 €
8.0	8x6x19x63	ZRSB-2M	20.69 €	ZRSB-2MP	20.69 €
9.5	9.5x6x19x63	ZRSB-3M	22.21 €	ZRSB-3MP	22.21 €
9.5	9.5x6x25x69	ZRSB-3ML	26.40 €	ZRSB-3MLP	26.40 €
11.0	11x6x25x69	ZRSB-4M	32.35 €	ZRSB-4MP	32.35 €
12.7	12.7x6x25x69	ZRSB-5M	34.71 €	ZRSB-5MP	34.71 €
16.0	16x6x25x69	ZRSB-6M	51.71 €	ZRSB-6MP	51.71 €
19.0	19x6x25x69	ZRSB-7M	65.02 €	ZRSB-7MP	65.02 €
25.0	25x6x25x69	ZRSB-9M	102.50 €	ZRSB-9MP	102.50 €



Ø fraisage	Dimensions	COUPE ALUMINIUM Réf.	Prix unitaire TARIF H.T.
	D1xD2xL1xL2		
6.0	6X6X19X50	ZRSB-1MNF	17.85 €
9.5	9.5X6X19X63	ZRSB-3MNF	24.38 €
12.7	12.7X6X25X69	ZRSB-5MNF	38.17 €
16.0	16X6X25X69	ZRSB-6MNF	56.89 €
19.0	19X6X25X69	ZRSB-7MNF	71.58 €

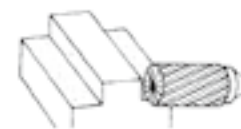

FRAISE LIME ROTATIVE CARBURE CYLINDRIQUE, AVEC BOUT ARRONDI, FORME C



réf. ZRSC

conditions de coupe recommandées p. 182



Ø fraisage	Dimensions	COUPE DOUBLE Réf.	Prix unitaire TARIF H.T.	COUPE SIMPLE Réf.	Prix unitaire TARIF H.T.
	D1xD2xL1xL2				
2.5	2.5x3x11x38	ZRSC-41M	8.42 €	ZRSC-41MP	8.42 €
3.0	3x3x14x38	ZRSC-42M	8.42 €	ZRSC-42MP	8.42 €
3.0	3x3x14x50	ZRSC-42ML2	11.66 €	ZRSC-42ML2P	11.66 €
3.0	3x3x14x75	ZRSC-42ML3	13.19 €	ZRSC-42ML3P	13.19 €
3.0	3x6x12x56	ZRSC-11M	16.67 €	ZRSC-11MP	16.67 €
3.0	3x6x16x60	ZRSC-12M	16.67 €	ZRSC-12MP	16.67 €
4.0	4x3x12.7x38	ZRSC-52M	20.20 €	ZRSC-52MP	20.20 €
4.0	4x6x16x50	ZRSC-13M	16.67 €	ZRSC-13MP	16.67 €
5.0	5x3x12.7x38	ZRSC-53M	20.20 €	ZRSC-53MP	20.20 €
5.0	5x6x16x50	ZRSC-14M	16.67 €	ZRSC-14MP	16.67 €
6.0	6x6x16x50	ZRSC-1M	16.67 €	ZRSC-1MP	16.67 €
6.0	6x6x25x50	ZRSC-1ML	22.85 €	ZRSC-1MLP	22.85 €
6.3	6.3x3x12.7x50	ZRSC-51M	13.79 €	ZRSC-51MP	13.79 €
8.0	8x6x19x63	ZRSC-2M	20.44 €	ZRSC-2MP	20.44 €
9.5	9.5x6x19x63	ZRSC-3M	22.49 €	ZRSC-3MP	22.49 €
9.5	9.5x6x25x69	ZRSC-3ML	26.45 €	ZRSC-3MLP	26.45 €
11.0	11x6x25x69	ZRSC-4M	32.22 €	ZRSC-4MP	32.22 €
12.7	12.7x6x25x69	ZRSC-5M	35.34 €	ZRSC-5MP	35.34 €
16.0	16x6x25x69	ZRSC-6M	44.42 €	ZRSC-6MP	44.42 €
19.0	19x6x25x69	ZRSC-7M	63.93 €	ZRSC-7MP	63.93 €
25.0	25x6x25x69	ZRSC-9M	96.78 €	ZRSC-9MP	96.78 €



Ø fraisage	Dimensions	COUPE ALUMINIUM Réf.	Prix unitaire TARIF H.T.
	D1xD2xL1xL2		
6.0	6X6X19X50	ZRSC-1MNF	18.32 €
9.5	9.5X6X19X63	ZRSC-3MNF	24.74 €
12.7	12.7X6X25X69	ZRSC-5MNF	38.88 €
19.0	19X6X25X69	ZRSC-7MNF	70.27 €

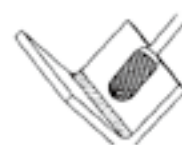

FRAISE LIME ROTATIVE CARBURE SPHÉRIQUE, FORME D



réf. ZRSD

conditions de coupe recommandées p. 182



Ø fraisage	Dimensions	COUPE DOUBLE Réf.	Prix unitaire TARIF H.T.	COUPE SIMPLE Réf.	Prix unitaire TARIF H.T.
	D1xD2xL1xL2				
2.5	2.5x3x2.3x38	ZRSD-41M	8.42 €	ZRSD-41MP	8.42 €
3.0	3x3x2.8x38	ZRSD-42M	8.42 €	ZRSD-42MP	8.42 €
3.0	3x3x2.8x50	ZRSD-42ML2	11.66 €	ZRSD-42ML2P	11.66 €
3.0	3x3x2.8x75	ZRSD-42ML3	13.19 €	ZRSD-42ML3P	13.19 €
3.0	3x6x2.8x50	ZRSD-11M	15.31 €	ZRSD-11MP	15.31 €
5.0	5x3x4x38	ZRSD-53M	20.20 €	ZRSD-53MP	20.20 €
5.0	5x6x4x50	ZRSD-14M	15.31 €	ZRSD-14MP	15.31 €
6.0	6x6x5x50	ZRSD-1M	15.31 €	ZRSD-1MP	15.31 €
6.3	6.3x3x5x44	ZRSD-51M	13.79 €	ZRSD-51MP	13.79 €
8.0	8x6x6.4x50	ZRSD-2M	16.50 €	ZRSD-2MP	16.50 €
9.5	9.5x6x8x52	ZRSD-3M	18.50 €	ZRSD-3MP	18.50 €
11.0	11x6x9.5x54	ZRSD-4M	21.33 €	ZRSD-4MP	21.33 €
12.7	12.7x6x11x55	ZRSD-5M	24.86 €	ZRSD-5MP	24.86 €
16.0	16x6x14x58	ZRSD-6M	34.98 €	ZRSD-6MP	34.98 €
19.0	19x6x16x62	ZRSD-7M	42.59 €	ZRSD-7MP	42.59 €
25.0	25x6x23x68	ZRSD-9M	73.16 €	ZRSD-9MP	73.16 €



Ø fraisage	Dimensions	COUPE ALUMINIUM Réf.	Prix unitaire TARIF H.T.
	D1xD2xL1xL2		
6.0	6X6X5X50	ZRSD-1MNF	16.84 €
9.5	9.5X6X8X52	ZRSD-3MNF	20.38 €
12.7	12.7X6X11X55	ZRSD-5MNF	27.33 €
16.0	16X6X14X58	ZRSD-6MNF	38.53 €
19.0	19X6X16X62	ZRSD-7MNF	46.84 €



FRAISE LIME ROTATIVE CARBURE OVALE, FORME E



réf. ZRSE

conditions de coupe recommandées p. 182



Ø fraisage	Dimensions	COUPE DOUBLE Réf.	Prix unitaire TARIF H.T.	COUPE SIMPLE Réf.	Prix unitaire TARIF H.T.
	D1xØD2xL1xL2				
3.0	3x3x5.5x38	ZRSE-41M	8.42 €	ZRSE-41MP	8.42 €
3.0	3x3x5.5x50	ZRSE-41ML2	11.66 €	ZRSE-41ML2P	11.66 €
3.0	3x3x5.5x75	ZRSE-41ML3	13.19 €	ZRSE-41ML3P	13.19 €
5.0	5x3x7.1x38	ZRSE-53M	20.20 €	ZRSE-53MP	20.20 €
6.0	6x6x9.5x50	ZRSE-1M	18.79 €	ZRSE-1MP	18.79 €
6.3	6.3x3x9.5x47	ZRSE-51M	13.79 €	ZRSE-51MP	13.79 €
9.5	9.5x6x16x60	ZRSE-3M	22.49 €	ZRSE-3MP	22.49 €
12.7	12.7x6x22x66	ZRSE-5M	32.93 €	ZRSE-5MP	32.93 €
16.0	16x6x25x69	ZRSE-6M	45.77 €	ZRSE-6MP	45.77 €
19.0	19x6x25x69	ZRSE-7M	61.50 €	ZRSE-7MP	61.50 €



Ø fraisage	Dimensions	COUPE ALUMINIUM Réf.	Prix unitaire TARIF H.T.
	D1xØD2xL1xL2		
9.5	9.5X6X16X60	ZRSE-3MNF	24.74 €
12.7	12.7X6X22X66	ZRSE-5MNF	36.22 €
16.0	16X6X25X69	ZRSE-6MNF	50.31 €
19.0	19X6X25X69	ZRSE-7MNF	67.63 €

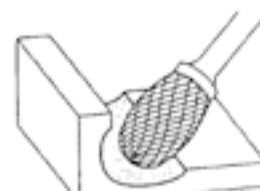

FRAISE LIME ROTATIVE CARBURE OGIVE AVEC BOUT ARRONDI, FORME F



réf. ZRSF

conditions de coupe recommandées p. 182



Ø fraisage	Dimensions	COUPE DOUBLE Réf.	Prix unitaire TARIF H.T.	COUPE SIMPLE Réf.	Prix unitaire TARIF H.T.
	D1xD2xL1xL2				
3.0	3x3x6x38	ZRSF-41M	8.42 €	ZRSF-41MP	8.42 €
3.0	3x3x12.7x38	ZRSF-42M	8.42 €	ZRSF-42MP	8.42 €
3.0	3x6x12.7x56	ZRSF-11M	17.44 €	ZRSF-11MP	17.44 €
3.0	3x3x12.7x50	ZRSF-42ML2	11.66 €	ZRSF-42ML2P	11.66 €
3.0	3x3x12.7x75	ZRSF-42ML3	13.19 €	ZRSF-42ML3P	13.19 €
5.0	5x3x12.7x38	ZRSF-53M	20.20 €	ZRSF-53MP	20.20 €
6.0	6x6x16x50	ZRSF-1M	17.44 €	ZRSF-1MP	17.44 €
6.3	6.3x3x12.7x50	ZRSF-51M	13.79 €	ZRSF-51MP	13.79 €
9.5	9.5x6x19x63	ZRSF-3M	21.98 €	ZRSF-3MP	21.98 €
11.0	11x6x25x69	ZRSF-4M	32.04 €	ZRSF-4MP	32.04 €
12.7	12.7x6x19x63	ZRSF-13M	32.04 €	ZRSF-13MP	32.04 €
12.7	12.7x6x25x69	ZRSF-5M	32.51 €	ZRSF-5MP	32.51 €
16.0	16x6x25x69	ZRSF-6M	44.95 €	ZRSF-6MP	44.95 €
19.0	19x6x25x69	ZRSF-7M	59.09 €	ZRSF-7MP	59.09 €
19.0	19x6x32x76	ZRSF-14M	74.40 €	ZRSF-14MP	74.40 €
19.0	19x6x38x82	ZRSF-15M	87.41 €	ZRSF-15MP	87.41 €



Ø fraisage	Dimensions	COUPE ALUMINIUM Réf.	Prix unitaire TARIF H.T.
	D1xD2xL1xL2		
6.0	6X6X19X50	ZRSF-1MNF	19.20 €
9.5	9.5X6X19X63	ZRSF-3MNF	24.20 €
12.7	12.7X6X25X69	ZRSF-5MNF	35.75 €
16.0	16X6X25X69	ZRSF-6MNF	49.49 €
19.0	19X6X32X76	ZRSF-14MNF	81.82 €

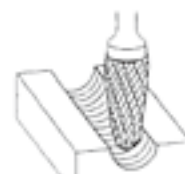

FRAISE LIME ROTATIVE CARBURE OGIVE AVEC BOUT POINTU, FORME G

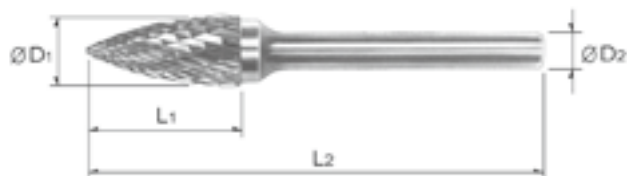

réf. ZRSG

conditions de coupe recommandées p. 182



Ø fraissage	Dimensions	COUPE DOUBLE Réf.	Prix unitaire TARIF H.T.	COUPE SIMPLE Réf.	Prix unitaire TARIF H.T.
	D1xD2xL1xL2				
3.0	3x3x6x38	ZRSG-41M	8.42 €	ZRSG-41MP	8.42 €
3.0	3x3x9.5x38	ZRSG-43M	8.42 €	ZRSG-43MP	8.42 €
3.0	3x3x12.7x38	ZRSG-44M	8.42 €	ZRSG-44MP	8.42 €
3.0	3x3x12.7x50	ZRSG-44ML2	11.66 €	ZRSG-44ML2P	11.66 €
3.0	3x3x12.7x75	ZRSG-44ML3	13.19 €	ZRSG-44ML3P	13.19 €
5.0	5x3x12.7x38	ZRSG-53M	20.20 €	ZRSG-53MP	20.20 €
6.0	6x6x16x50	ZRSG-1M	17.44 €	ZRSG-1MP	17.44 €
6.3	6.3x3x12.7x50	ZRSG-51M	13.79 €	ZRSG-51MP	13.79 €
8.0	8x6x19x63	ZRSG-2M	21.21 €	ZRSG-2MP	21.21 €
9.5	9.5x6x19x63	ZRSG-3M	23.45 €	ZRSG-3MP	23.45 €
12.7	12.7x6x19x63	ZRSG-13M	31.93 €	ZRSG-13MP	31.93 €
12.7	12.7x6x25x69	ZRSG-5M	31.93 €	ZRSG-5MP	31.93 €
16.0	16x6x25x69	ZRSG-6M	44.37 €	ZRSG-6MP	44.37 €
19.0	19x6x25x69	ZRSG-7M	59.09 €	ZRSG-7MP	59.09 €
19.0	19x6x38x82	ZRSG-15M	87.41 €	ZRSG-15MP	87.41 €



FRAISE LIME ROTATIVE CARBURE FLAMME, FORME H

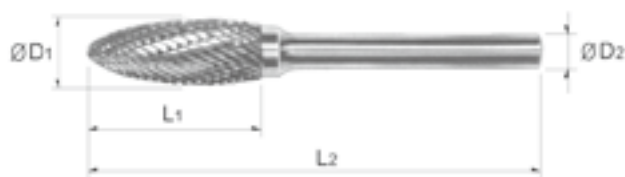

réf. ZRSH

conditions de coupe recommandées p. 182



Ø fraissage	Dimensions	COUPE DOUBLE Réf.	Prix unitaire TARIF H.T.	COUPE SIMPLE Réf.	Prix unitaire TARIF H.T.
	D1xD2xL1xL2				
3.0	3x3x6.3x38	ZRSH-41M	8.42 €	ZRSH-41MP	8.42 €
3.0	3x3x6.3x50	ZRSH-41ML2	11.66 €	ZRSH-41ML2P	11.66 €
3.0	3x3x6.3x75	ZRSH-41ML3	13.19 €	ZRSH-41ML3P	13.19 €
5.0	5x3x9.5x38	ZRSH-53M	20.20 €	ZRSH-53MP	20.20 €
8.0	8x6x19x63	ZRSH-2M	23.09 €	ZRSH-2MP	23.09 €
12.7	12.7x6x32x76	ZRSH-5M	47.07 €	ZRSH-5MP	47.07 €
16.0	16x6x36x80	ZRSH-6M	65.02 €	ZRSH-6MP	65.02 €
19.0	19x6x41x85	ZRSH-7M	82.64 €	ZRSH-7MP	82.64 €



FRAISE LIME ROTATIVE CARBURE CONIQUE 60°, FORME J

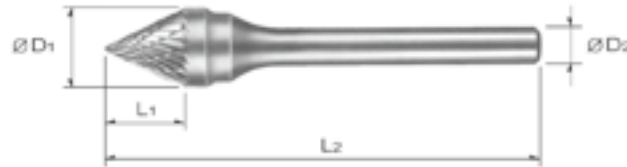

réf. ZRSJ

conditions de coupe recommandées p. 182

Ø fraisage	Dimensions	COUPE DOUBLE Réf.	Prix unitaire TARIF H.T.	COUPE SIMPLE Réf.	Prix unitaire TARIF H.T.
	D1xD2xL1xL2				
3.0	3x3x2.5x38	ZRSJ-42M	8.42 €	ZRSJ-42MP	8.42 €
6.0	6x6x4x50	ZRSJ-1M	15.31 €	ZRSJ-1MP	15.31 €
9.5	9.5x6x8x55	ZRSJ-3M	20.09 €	ZRSJ-3MP	20.09 €
12.7	12.7x6x11x58	ZRSJ-5M	24.44 €	ZRSJ-5MP	24.44 €
16.0	16x6x13.5x61	ZRSJ-6M	32.51 €	ZRSJ-6MP	32.51 €
19.0	19x6x17.5x65	ZRSJ-7M	42.71 €	ZRSJ-7MP	42.71 €
25.0	25x6x21.5x68	ZRSJ-9M	68.50 €	ZRSJ-9MP	68.50 €



FRAISE LIME ROTATIVE CARBURE CONIQUE 90°, FORME K

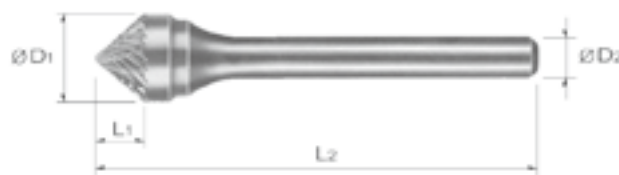

réf. ZRSK

conditions de coupe recommandées p. 182

Ø fraisage	Dimensions	COUPE DOUBLE Réf.	Prix unitaire TARIF H.T.	COUPE SIMPLE Réf.	Prix unitaire TARIF H.T.
	D1xD2xL1xL2				
3.0	3x3x1.5x38	ZRSK-42M	8.42 €	ZRSK-42MP	8.42 €
6.0	6x6x3x50	ZRSK-1M	15.31 €	ZRSK-1MP	15.31 €
9.5	9.5x6x4.7x52	ZRSK-3M	20.09 €	ZRSK-3MP	20.09 €
12.7	12.7x6x6.3x54	ZRSK-5M	24.44 €	ZRSK-5MP	24.44 €
16.0	16x6x8x57	ZRSK-6M	32.51 €	ZRSK-6MP	32.51 €
19.0	19x6x9.5x58	ZRSK-7M	42.71 €	ZRSK-7MP	42.71 €
25.0	25x6x12.7x60	ZRSK-9M	68.50 €	ZRSK-9MP	68.50 €



FRAISE LIME ROTATIVE CARBURE CONIQUE BOUT ARRONDI, FORME L



réf. ZRSL

conditions de coupe recommandées p. 182



Ø fraisage	Dimensions	COUPE DOUBLE Réf.	Prix unitaire TARIF H.T.	COUPE SIMPLE Réf.	Prix unitaire TARIF H.T.
	D1xD2xL1xL2				
3.0	3x3x9.5x38 - 8°	ZRSL-41M	8.42 €	ZRSL-41MP	8.42 €
3.0	3x3x12.7x38 - 8°	ZRSL-42M	8.42 €	ZRSL-42MP	8.42 €
3.0	3x3x12.7x50 - 8°	ZRSL-42ML2	11.66 €	ZRSL-42ML2P	11.66 €
3.0	3x3x12.7x75 - 8°	ZRSL-42ML3	13.14 €	ZRSL-42ML3P	13.14 €
5.0	5x3x12.7x38 - 14°	ZRSL-53M	20.20 €	ZRSL-53MP	20.20 €
6.0	6x6x16x50 - 14°	ZRSL-1M	17.85 €	ZRSL-1MP	17.85 €
8.0	8x6x22x69 - 14°	ZRSL-2M	24.57 €	ZRSL-2MP	24.57 €
9.5	9.5x6x27x74 - 14°	ZRSL-3M	28.09 €	ZRSL-3MP	28.09 €
12.7	12.7x6x28x76 - 14°	ZRSL-4M	34.35 €	ZRSL-4MP	34.35 €
16.0	16x6x30x77 - 14°	ZRSL-5M	61.38 €	ZRSL-5MP	61.38 €
19.0	19x6x38x85 - 14°	ZRSL-7M	89.24 €	ZRSL-7MP	89.24 €



Ø fraisage	Dimensions	COUPE ALUMINIUM Réf.	Prix unitaire TARIF H.T.
	D1xD2xL1xL2		
9.5	9.5X6X27X74(14°)	ZRSL-3MNF	30.93 €
12.7	12.7X6X28X76(14°)	ZRSL-4MNF	37.80 €
16.0	16X6X30X77(14°)	ZRSL-5MNF	67.51 €
19.0	19X6X38X85(14°)	ZRSL-7MNF	98.13 €



FRAISE LIME ROTATIVE CARBURE CONIQUE, FORME M

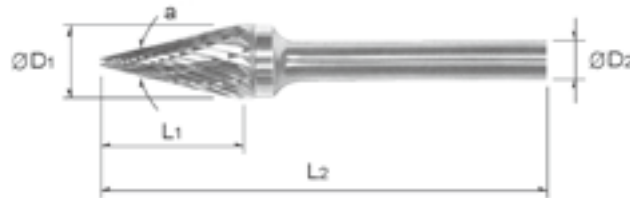

réf. ZRSM

conditions de coupe recommandées p. 182

Ø fraisage	Dimensions	COUPE DOUBLE Réf.	Prix unitaire TARIF H.T.	COUPE SIMPLE Réf.	Prix unitaire TARIF H.T.
	D1xD2xL1xL2				
3.0	3x3x8.9x38	ZRSM-41M	8.42 €	ZRSM-41MP	8.42 €
3.0	3x3x11x38	ZRSM-42M	8.42 €	ZRSM-42MP	8.42 €
3.0	3x3x11x50	ZRSM-42ML2	11.66 €	ZRSM-42ML2P	11.66 €
3.0	3x3x11x75	ZRSM-42ML3	13.14 €	ZRSM-42ML3P	13.14 €
3.0	3x3x16x38	ZRSM-43M	8.42 €	ZRSM-43MP	8.42 €
5.0	5x3x12.7x38	ZRSM-53M	20.20 €	ZRSM-53MP	20.20 €
6.0	6x6x12.7x50	ZRSM-1M	16.90 €	ZRSM-1MP	16.90 €
6.0	6x6x19x50	ZRSM-2M	17.85 €	ZRSM-2MP	17.85 €
6.0	6x6x25x50	ZRSM-3M	19.03 €	ZRSM-3MP	19.03 €
6.3	6.3x3x12.7x53	ZRSM-51M	13.79 €	ZRSM-51MP	13.79 €
9.5	9.5x6x16x63	ZRSM-4M	28.15 €	ZRSM-4MP	28.15 €
12.7	12.7x6x22x69	ZRSM-5M	35.34 €	ZRSM-5MP	35.34 €
16.0	16x6x25x73	ZRSM-6M	47.07 €	ZRSM-6MP	47.07 €



FRAISE LIME ROTATIVE CARBURE CONIQUE INVERSÉE, FORME N



réf. ZRSN

conditions de coupe recommandées p. 182

Ø fraisage	Dimensions	COUPE DOUBLE Réf.	Prix unitaire TARIF H.T.	COUPE SIMPLE Réf.	Prix unitaire TARIF H.T.
	D1xD2xL1xL2				
2.5	2.5x3x3x38	ZRSN-41M	8.42 €	ZRSN-41MP	8.42 €
3.0	3x3x4x38	ZRSN-42M	8.42 €	ZRSN-42MP	8.42 €
5.0	5x3x6.3x38	ZRSN-53M	20.20 €	ZRSN-53MP	20.20 €
6.0	6x6x8x50	ZRSN-1M	17.04 €	ZRSN-1MP	17.04 €
6.3	6.3x3x6x44	ZRSN-51M	15.15 €	ZRSN-51MP	15.15 €
9.5	9.5x6x9.5x53	ZRSN-2M	24.86 €	ZRSN-2MP	24.86 €
12.7	12.7x6x12.7x57	ZRSN-4M	35.17 €	ZRSN-4MP	35.17 €
16.0	16x6x19x63	ZRSN-6M	47.42 €	ZRSN-6MP	47.42 €
19.0	19x6x16x60	ZRSN-7M	50.78 €	ZRSN-7MP	50.78 €



CHAMPS D'APPLICATION DES FRAISES LIMES ROTATIVES

Matière Usinée	COUPE SIMPLE	COUPE DOUBLE	COUPE ALU	COUPE DIAMANT	BRISE COPEAUX
ALUMINUM			•		
LAITON, BRONZE, CUIVRE	•	•			•
FIBRE DE VERRE				•	
FONTES	•	•			•
PLASTIQUES			•		
ACIER, Hrc 40~55	•	•		•	•
ACIER, Hrc 55~60	•	•		•	•
ACIER CARBONE	•	•			•
ACIER, NICKEL CHROME	•	•		•	•
ACIER, CONSTRUCTIONS SOUDEES	•	•			•
TITANE	•	•			•
ZINC			•		

RECOMMANDATIONS DE VITESSES DES FRAISES LIMES ROTATIVES

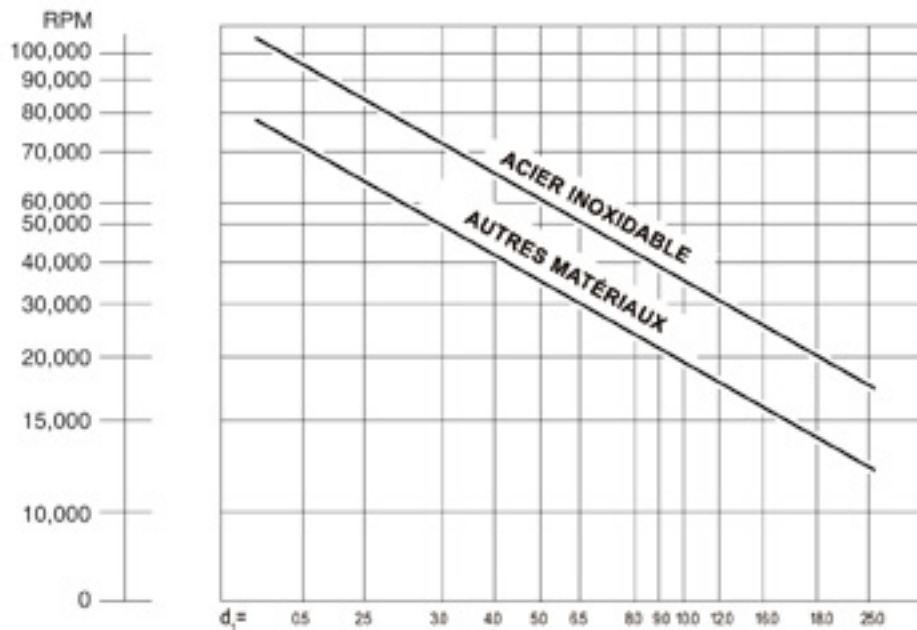

Réf.	Désignation	Dimensions	Quantité	Prix unitaire TARIF H.T.
A402 SET 01 N	COFFRET FORETS HSS DIN338, affûtage en croix à partir du Ø1.6mm, revêtus TiN en bout	1.0-10.0 (par 0.5)	19 pièces	85.93 €
A402 SET 02 N	COFFRET FORETS HSS DIN338, affûtage en croix à partir du Ø1.6mm, revêtus TiN en bout	1.0-13.0 (par 0.5)	25 pièces	167.74 €
A402 SET 03 N	COFFRET FORETS HSS DIN338, affûtage en croix à partir du Ø1.6mm, revêtus TiN en bout	1.0-10.5 (par 0.5)+3.3+4.2+6.8+10.2	24 pièces	134.41 €
A403 SET 01 N	COFFRET FORETS HSSCo5 DIN338, affûtage en croix à partir du Ø1.6mm, revêtus TiN en bout	1.0-10.0 (par 0.5)	19 pièces	109.07 €
A403 SET 02 N	COFFRET FORETS HSSCo5 DIN338, affûtage en croix à partir du Ø1.6mm, revêtus TiN en bout	1.0-13.0 (par 0.5)	25 pièces	212.09 €
A403 SET 03 N	COFFRET FORETS HSSCo5 DIN338, affûtage en croix à partir du Ø1.6mm, revêtus TiN en bout	1.0-10.5 (par 0.5)+3.3+4.2+6.8+10.2	24 pièces	150.21 €
A425 SET 02 V	COFFRET FORETS HSS DIN338, traité VAP à partir du Ø2mm	1.0-10.0 (par 0.5)	19 pièces	43.84 €
A425 SET 01 V	COFFRET FORETS HSS DIN338, traité VAP à partir du Ø2mm	1.0-13.0 (par 0.5)	25 pièces	87.46 €
A429 SET 01	COFFRET FORETS HSSCo5 DIN338, non revêtus, pour matières dures	1.0-13.0 (par 0.5)	25 pièces	146.51 €
A424 SET 01	COFFRET FORETS HSSCo5 DIN338, affûtage en croix à partir de Ø1.6mm, non revêtus	1.0-13.0 (par 0.5)	25 pièces	162.19 €
A424 SET 02	COFFRET FORETS HSSCo5 DIN338, affûtage en croix à partir de Ø1.6mm, non revêtus	1.0-10.0 (par 0.1)	91 pièces	424.57 €
A405 SET 01 F	COFFRET FORETS HSSCo5 DIN1897, Type DH100, revêtus TiAIN	2.0-10.0 (par 0.1)	81 pièces	1 072.06 €
A406 SET 02 F	COFFRET FORETS HSSCo5 DIN338, Type DH100, revêtus TiAIN	2.0-10.0 (par 0.1)	81 pièces	1 232.90 €
Z120 SET 01	COFFRET FRAISES À LAMER MEDIUM HSS-E 3 dents	1x Ø6-8-10-11-15-18	6 pièces	120.28 €
Z156 SET 01	COFFRET FRAISES À ÉBAVURER 3 DENTS, HSSCo8, non revêtues	1x Ø6.3-8.3-10.4-12.4- 16.5-20.5-25	7 pièces	202.42 €



corai
Outils coupants

FORETS

FRAISES

TARAUDS



corai

INDEX GÉNÉRAL PAR RÉFÉRENCE



réf.	page	réf.	page	réf.	page	réf.	page
A202	p. 4	B206	p. 60	C617K	p. 84	C782 C783	p. 141
A203	p. 6	B207	p. 62	C618	p. 85	C784	p. 142
A204	p. 8	B213	p. 58	C618X	p. 85	C785	p. 143
A205	p. 10	B215	p. 47	C623K	p. 87	C786	p. 144
A206	p. 12	B218	p. 49	C626X	p. 91	C787	p. 145
A231	p. 2	B221	p. 51	C630K	p. 86	C788	p. 148
A232	p. 3	B403	p. 56	C631K	p. 86	C789	p. 148
A233	p. 13	B408	p. 61	C632K	p. 88	C790	p. 149
A234	p. 13	B409	p. 63	C633K	p. 89	C791	p. 149
A402	p. 23	B415	p. 59	C634K	p. 90	C792	p. 150
A402 SET 01 N	p. 183	B419	p. 48	C636K	p. 91	C793	p. 150
A402 SET 02 N	p. 183	B423	p. 50	C651	p. 102	FM	p. 64
A402 SET 03 N	p. 183	B427	p. 52	C653	p. 102	FP200	p. 64
A403	p. 21	B700	p. 40	C654	p. 103	FT200	p. 64
A403 SET 01 N	p. 183	B703	p. 41	C655	p. 103	Z102	p. 160
A403 SET 02 N	p. 183	B704	p. 42	C656	p. 104	Z103	p. 161
A403 SET 03 N	p. 183	B705	p. 43	C657	p. 104	Z104	p. 162
A405 SET 01 F	p. 183	B706	p. 44	C659	p. 105	Z105	p. 163
A406 SET 02 F	p. 183	B707	p. 45	C660	p. 105	Z106	p. 164
A421	p. 18	B720	p. 46	C700	p. 112	Z107	p. 165
A423	p. 25	B721	p. 53	C701	p. 114	Z108	p. 166
A424 SET 01	p. 183	B722	p. 54	C702	p. 115	Z120	p. 169
A424 SET 02	p. 183	C305	p. 68	C703	p. 116	Z120 SET 01	p. 183
A425	p. 19	C306	p. 69	C704	p. 117	Z156	p. 151
A425 SET 01 V	p. 183	C307	p. 69	C705	p. 111	Z156 SET 01	p. 183
A425 SET 02 V	p. 183	C308	p. 70	C707	p. 119	ZRSA	p. 172
A427	p. 27	C310	p. 70	C708	p. 120	ZRSB	p. 173
A428	p. 28	C321	p. 71	C709	p. 121	ZRSC	p. 174
A429 SET 01	p. 183	C600	p. 79	C710	p. 118	ZRSD	p. 175
A452	p. 30	C600K	p. 80	C716	p. 122	ZRSE	p. 176
A453	p. 29	C604	p. 80	C717	p. 123	ZRSF	p. 177
A455	p. 31	C604X	p. 81	C719	p. 124	ZRSG	p. 178
A456	p. 32	C605K	p. 81	C720	p. 125	ZRSH	p. 178
A461	p. 33	C609	p. 82	C734	p. 126	ZRSJ	p. 179
A463	p. 33	C609K	p. 82	C735	p. 127	ZRSK	p. 179
A480	p. 34	C611	p. 83	C740	p. 136	ZRSL	p. 180
B201	p. 55	C613K	p. 83	C741	p. 137	ZRSM	p. 181
B202	p. 57	C617	p. 84	C780 C781	p. 140	ZRSN	p. 181

E-mail : corai@corai.com

Tél : 01.81.15.22.50

Fax : 01.81.15.22.51

<http://www.corai.com>



corai